

# **MITSUBISHI CNC** **MELDAS 600L Series**

## **PARAMETER MANUAL**

## Introduction





This Parameter Manual has been prepared with all the information needed in order to operate the MELDAS 600L Series, software-fixed type of CNC (hereafter NC) systems which are designed to execute high-performance contour control with lathe.

This manual contains details on all the functions of MELDAS 600L Series but the system actually ordered may not necessarily be provided with all the options mentioned. When the system is used, therefore, not all the options may necessarily be operational and, in any event, reference should be made to the Specifications Manual issued by the machine maker.

### Points to be observed when reading this manual

- (1) This manual contains general descriptions as seen from the standpoint of NC (numerical control) and thus reference should be made to the Instruction Manual issued by the machine maker for descriptions of individual machine tools.  
For items described as "Restrictions" or "Usable State" in this manual, the instruction manual issued by the machine maker takes precedence over this manual.
- (2) An effort has been made to describe special handling of this machine, but items that are not described must be interpreted as "not possible".

### CAUTION

-  For items described as "Restrictions" or "Usable State" in this manual, the instruction manual issued by the machine maker takes precedence over this manual.
-  An effort has been made to describe special handling of this machine, but items that are not described must be interpreted as "not possible".
-  This manual is written on the assumption that all option functions are added. Refer to the Specifications Manual issued by the machine maker before starting use.
-  Some screens and functions may differ or may not be usable depending on the NC version.
-  Refer to the instruction manual issued by each machine maker for details on each machine tool.

## Precautions for Safety

Always read the Specifications Manual issued by the machine maker, this manual, related manuals and attached documents before installation, operation, programming, maintenance or inspection to ensure correct use.

Understand this numerical controller, safety items and cautions before using the unit.

This manual ranks the safety precautions into "DANGER", "WARNING" and "CAUTION".



**DANGER**

When the user may be subject to imminent fatalities or major injuries if handling is mistaken.



**WARNING**

When the user may be subject to fatalities or major injuries if handling is mistaken.



**CAUTION**

When the user may be subject to injuries or when physical damage may occur if handling is mistaken.

Note that even items ranked as "  **CAUTION**", may lead to major results depending on the situation. In any case, important information that must always be observed is described.



**DANGER**

Not applicable in this manual.







**WARNING**

Not applicable in this manual.





**CAUTION**

### 1. Items related to product and manual

-  For items described as "Restrictions" or "Usable State" in this manual, the instruction manual issued by the machine maker takes precedence over this manual.
-  An effort has been made to describe special handling of this machine, but items that are not described must be interpreted as "not possible".
-  This manual is written on the assumption that all option functions are added. Refer to the Specifications Manual issued by the machine maker before starting use.
-  Some screens and functions may differ or may not be usable depending on the NC version.
-  Refer to the instruction manual issued by each machine maker for details on each machine tool.

### 2. Items related to parameters

-  If SV018 is not set to "360" or "180", the function will not activate correctly. Always set this parameter to "360" or "180".
-  Opening another screen is opened without saving the settings made on the MELDAS diagn Parameter screen, all of the set diagnosis information parameters will be invalidated.

# CONTENTS

<b>1. SCREEN CONFIGURATION.....</b>	<b>1-1</b>
1.1 Screen Transition Diagram.....	1-1
<b>2. CONTROL PARAMETER.....</b>	<b>2-1</b>
<b>3. PARAMETERS (USER) .....</b>	<b>3-1</b>
3.1 Axis Parameters.....	3-1
3.2 Setup Parameters .....	3-2
3.3 Input/Output Parameters.....	3-8
3.3.1 RS-232C I/O device parameter setting examples and cable connections .....	3-11
3.4 Barrier Data.....	3-12
<b>4. MACHINE PARAMETERS .....</b>	<b>4-1</b>
4.1 Selecting the Machine Parameters.....	4-1
4.2 Base Axis Parameters .....	4-2
4.3 Base System Parameters.....	4-4
4.4 Base Common Parameters .....	4-7
4.5 Axis Specification Parameters.....	4-18
4.6 Zero (Reference) Point Return Parameters.....	4-24
4.7 Servo Parameters .....	4-27
4.7.1 Servo Parameters.....	4-28
4.7.2 Supplementary Explanation (MDS-B-V1/V2).....	4-54
4.7.3 Intelligent Servo D/A Output Function.....	4-57
4.7.4 Standard Parameters Setting (MDS-B-V1/V2, intelligent servo).....	4-60
4.8 Spindle Parameters.....	4-75
4.8.1 Spindle NC Parameters .....	4-75
4.8.2 Spindle Parameters .....	4-82
4.8.3 Supplementary Explanation (for D/A output functions).....	4-118
4.8.4 Spindle-Type Servo Parameters .....	4-121
4.9 PLC Constants .....	4-122
4.9.1 PLC Constants.....	4-122
4.9.2 PLC Timer .....	4-123
4.9.3 PLC Counter.....	4-124
4.9.4 Selecting the PLC Bit.....	4-124
4.10 Custom Variables .....	4-124
4.11 Macro List.....	4-125
4.12 Position Switch.....	4-128
4.13 Machine Error Compensation .....	4-130
4.13.1 Function Outline.....	4-130
4.13.2 Setting Compensation Data .....	4-133
4.13.3 Example in Using a Linear Axis as the Base Axis .....	4-135
4.13.4 Example in Using a Rotation Axis as the Base Axis.....	4-137
<b>5. ABSOLUTE POSITION SETTING PARAMETERS .....</b>	<b>5-1</b>
5.1 Absolute Position Set .....	5-2
<b>6. MELDAS DIAGNOSIS PARAMETERS.....</b>	<b>6-1</b>

## 1.1 Screen Transition Diagram

# 1. SCREEN CONFIGURATION

## 1.1 Screen Transition Diagram

When a parameter key is pressed, the following menus appear, and the parameters can be set/displayed on each respective screen. Refer to section "2. CONTROL PARAMETER" for details on setting the control parameters.

**(Note)** After the power is turned ON, the user parameters can be set but the machine parameters can only be displayed.

Refer to section "4.1 Selecting the Machine Parameters" for details on setting the machine parameters.

Control parameter	Posn disp 1	Posn disp 2	Posn disp 3	Operate search	Graphic	Common variabl	Local variabl	PLC switch	Ctrl Param	
User parameter	Axis param	Setup param	I/O param	Barrier data			Area copy	Area paste	Next axis	Next system
Machine parameter	BaseAx param	BaseSys param	BaseCom param	Axis spec	ZP-rtn param		Area copy	Area paste	Next axis	Next system
	Servo param	Spindle NC prm	Spindle param	Spindle typ sv			Area copy	Area paste	Next axis	Next system
	PLC constnt	PLC timer	PLC counter	Bit select			Area copy	Area paste	Next axis	Next system
	Custom variabl	Macro list	Posn switch	Er comp param	Er comp data	Variabl clear	Area copy	Area paste	Next axis	Next system

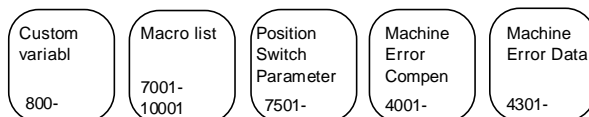
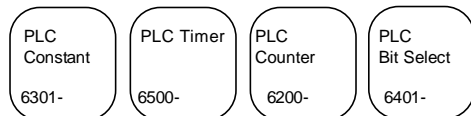
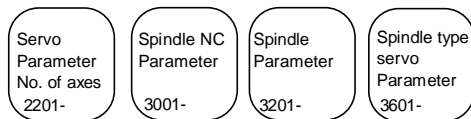

## 2. CONTROL PARAMETER

### 2. CONTROL PARAMETER

Select the item and press the menu key  ON or  OFF .

For parameters indicated with a "\*" in the table, turn the NC power OFF after setting. The setting is validated after the power is turned ON again.

#	Item	Setting	Details
8101	G00 dry run	ON	The external manual feedrate is enabled in respect to rapid traverse (G0, G27, G28, G29, G30, G53).
		OFF	The "rapid traverse rate * rapid traverse override value" set in the Machine parameters is applied.
8102	Macro single	ON	The macro block is handled as one block. The single block operation can be stopped at each macro block.
		OFF	The macro block is not handled as one block. The program is processed at a high speed.
8103	Middle point ignore	ON	During G28 or G30 reference point return command, the middle point designated in the program is ignored, and the axis returns directly to the reference point.
		OFF	During G28 or G30 the program designation is followed, and the axis returns to the reference point via the middle point.
8104	(Not used)	ON	
		OFF	
8105	Machine lock rapid	ON	When carrying out automatic operation in the machine lock state, the feedrate becomes the machine lock speed. The machine lock speed is set with the Machine parameter's Axis specification parameter "#2001 rapid".
		OFF	During machine lock, the feedrate is the commanded speed, and is the same process time as normal automatic operation.
8106	ABS/INC Addr.	ON	The absolute/incremental changeover is carried out with the address set in the parameters.
		OFF	The absolute/incremental changeover is carried out with the G code (G90/G91).
8107	G04 time fixed	ON	The G04 command is a time designation in both the synchronous feed mode (G95) and asynchronous feed mode (G94).
		OFF	The G04 command is a time designation in the asynchronous feed mode (G94), and a rotation designation in the synchronous feed mode (G95).
8108	Rad compen intrf byp	ON	During the nose R compensation interference check, the path is changed so that the workpiece is not cut into by the tool radius.
		OFF	During the nose R compensation interference check, if the block is determined to cause cutting into the workpiece by the tool radius, an alarm is generated before execution, and the operation stops.
8109			

## 2. CONTROL PARAMETER

#	Item	Setting	Details
8110	Decimal point type 2	ON	1 of a position command data without a decimal point command is controlled as 1mm (1 inch).
		OFF	1 of a position command data without a decimal point command is controlled as the minimum input command unit (0.01mm, 0.001mm or 0.0001mm) designated in the specifications.
8111	(Not used)	ON	
		OFF	
8112	(Not used)	ON	
		OFF	
8113	G0 interpolation OFF	ON	When positioning in the G00 mode, each axis independently moves at the respective rapid traverse rate. The path is not linear in respect to the end point.
		OFF	When positioning in the G00 mode, the axis moves at the shortest distance linearly in respect to the end point.
8114	Precision thrd cut E	ON	When cutting an inch thread, address E designates the precision lead.
		OFF	When cutting an inch thread, address E designates the number of threads per inch.
8115	Radius compen type B	ON	When nose R compensation or executing start up or a cancel command during radius compensation, the intersecting point of the command block and next command block is operated.
		OFF	When nose R compensation or executing start up or a cancel command during radius compensation, the start up or cancel command block are not targets for the intersecting point operation. The offset vector in the command right angle direction is applied.
8116	Ext deceleration OFF	ON	Even if the machine interface signal's external deceleration signal is input, it is ignored. (The machine's rapid traverse rate is not decelerated.)
		OFF	When the external deceleration signal is input, the machine's feedrate decelerates to the speed set with the Machine parameters.
8117	Initial inch*	ON	The inch command mode is entered as the default when the power is turned ON. (Inch settings are used for the parameters and compensation amounts, etc.)
		OFF	The metric command mode is entered as the default when the power is turned ON. (The input setting unit is also a metric setting.)
8118	Initial absolute val	ON	The absolute value command mode is the initial state when the power is turned ON.
		OFF	The incremental value command mode is the initial state when the power is turned ON.
8119	Initial synchr feed	ON	The synchronous feed mode is the initial state when the power is turned ON.
		OFF	The asynchronous feed mode is the initial state when the power is turned ON.

## 2. CONTROL PARAMETER

#	Item	Setting	Details
8120	Init cnst prphl spd	ON	The constant surface speed control mode is the initial state when the power is turned ON.
		OFF	The constant surface speed control cancel mode is the initial state when the power is turned ON.
8121	Initial Z-X plane	ON	G18 (plane selection ZX) mode is the initial state when the power is turned ON.
		OFF	G17 (plane selection XY) mode or G19 (plane selection YZ) mode is the initial state when the power is turned ON.
8122	Initial Y-Z plane	ON	G19 (plane selection YZ) mode is the initial state when the power is turned ON.
		OFF	G17 (plane selection XY) mode or G18 (plane selection ZX) mode is the initial state when the power is turned ON.
8123	Initial G00	ON	G00 (positioning) mode is the initial state when the power is turned ON.
		OFF	G01 (linear interpolation) mode is the initial state when the power is turned ON.
8124	(Not used)	ON	
		OFF	
8125	G83/87 rapid	ON	After completing each step in the deep hole drilling cycle, the axis returns by "d" (parameter setting), and then the next step is executed.
		OFF	After completing each step in the deep hole drilling cycle, the axis returns to the R point, and then the next step is executed.
8126	Fixed cycle modal	ON	During the Fixed cycle mode, movement to the hole drilling position follows the NC unit modal state (G0, G01).
		OFF	During the Fixed cycle mode, the axis is positioned to the hole drilling position with G00.
8127	Lathe cycle mode	ON	If there is a block without movement in the lathe cycle (G77 to G79) mode, the same process (G77 to G79) is carried out again. (G code type 2)
		OFF	If there is a block without movement in the lathe cycle (G77 to G79) mode, the lathe cycle is not executed.
8128	(Not used)	ON	
		OFF	
8129	Synchronous tapping	ON	The synchronous tapping is controlled.
		OFF	The synchronous tapping is not controlled.
8130	T-life manage valid	ON	The tool life management is controlled.
		OFF	The tool life management is not controlled.
8131	(Not used)	ON	
		OFF	
8132	(Not used)	ON	
		OFF	
8133	G code type 1		Select the G code series 1 to 3.
8134	G code type 2		The standard G code is type 2.
8135	G code type 3		Type 3 is for additional specifications.



## 2. CONTROL PARAMETER

#	Item	Setting	Details
8136	Interrupt amt reset	ON	By pressing the reset button, the amount interrupted with manual or handle feed (when manual ABS is OFF) is cleared to zero. (The coordinate system deviated by the interruption are returned to the original values.)
		OFF	Even if the reset button is pressed, the amount interrupted with manual or handle feed (when manual ABS is OFF) is held. (The coordinate system deviated by the interruption are held.)
8137	G46 no reverse error	ON	In cases when the compensation direction reverses during G46 execution, when an error occurs it will not be interpreted as an error. Instead the process will be executed in the same compensation direction.
		OFF	In cases when the compensation direction reverses during G46 execution, an error will occur.
8138 to 8139	(Not used)	ON	
		OFF	
8140	Edit lock B	ON	Editing of a label No. 8000 to 9999 machining program is locked.
		OFF	Editing of a label No. 8000 to 9999 machining program is enabled.
8141	(Not used)	ON	
		OFF	
8142	Start point alarm	ON	If the operation start point cannot be obtained, a program error will occur.
		OFF	The process starts after the movement block is completed.
8143			
8144	Milling G16	ON	The default value for the plane selection is set to the G16 plane when starting the milling mode.
		OFF	The default value for the plane selection is set to the G17 plane when starting the milling mode.
8145	Milling G19	ON	The default value for the plane selection is set to the G19 plane when starting the milling mode.
		OFF	The default value for the plane selection is set to the G17 plane when starting the milling mode.
8146 to 8157	(Not used)	ON	
		OFF	
8158	Tool set type 2	ON	If data without a decimal point (ex., 1) is set on the Tool offset or Wear compensation screen, the data will be input as 1.000 (1mm/inch).
		OFF	If data without a decimal point (ex., 1) is set on the Tool offset or Wear compensation screen, the data will be input as the minimum setting unit determined by the specifications.
8159	(Not used)	ON	
		OFF	

### 3. PARAMETERS (USER)

#### 3.1 Axis Parameters

Set the necessary parameters for each axis.

For parameters indicated with a "\*" in the table, turn the NC power OFF after setting. The setting is validated after the power is turned ON again.

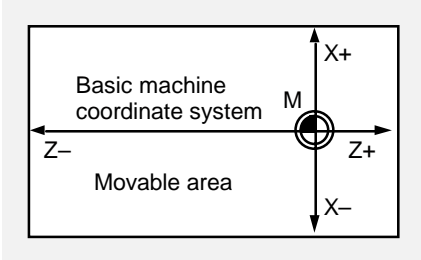
#	Item	Details	Setting range (unit)
8201	Mirror image	In memory and MDI operation, this highlights the symbol for the next block movement data (incremental amount).	0 : Mirror image invalid 1 : Mirror image valid
8202	Automatic dog type	The first reference point return is always dog-type, but this selects either dog-type or high-speed (memory type) for the second and subsequent reference point returns.	0 : High-speed return 1 : Dog-type return
8203	Manual dog type	This sets the manual reference point return method for the function above.	0 : High-speed return 1 : Dog-type return
8204	Axis removal	Not used.	0
8205 to 8206			
8207	Soft limit invalid	The values set for parameters No.8208 and No.8209 are ignored.	0: Soft limit valid 1: Soft limit invalid
8208 8209	Soft limit (-) Soft limit (+)	<p>The movable range in the negative and positive directions from the zero point of the basic machine coordinate system is set for each axis.</p> 	<p>±99999.999 (mm)</p> <p>If the same value (other than 0) is set for No.8208 and No.8209, this function will be invalidated.</p> <p><b>(Example)</b> No.8208 = 10. No.8209 = 10.</p>

## 3.2 Setup Parameters

### 3.2 Setup Parameters

This screen is configured of two pages.

For parameters indicated with a "\*" in the table, turn the NC power OFF after setting. The setting is validated after the power is turned ON again.

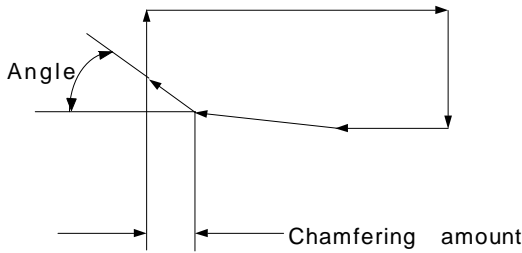
#	Item	Details	Setting range (unit)
8001 8002 8003	Plane <I> <J> <K>	These set the control axis addresses corresponding to the plane selection. The tool compensation axis becomes the axis set in I, J, and K.	X, Z, Y and other control axis addresses
8004 8005 8006	Aux-plane <I> <J> <K>	These set the parallel axis addresses corresponding to the above setting axes.	
8007			
8008			
8009			
8010	G02/03 Error	This sets the tolerance for the radial error at the end point of the circular command.	0 to 0.100 (mm)
8011	Chamfer value	This sets the chamfering distance of the thread area in the thread cutting cycle (G76, G78).	0 to 127 (0.1 lead)
8012	Chamfer angle	This sets the chamfering angle of the thread area in the thread cutting cycle (G76, G78). 	0 to 89 (°)
8013	G71 Minimum thick	This sets the remainder as the cut amount at the end of the rough cutting cycle (G71, G72). But the cycle is not undertaken when this is less than the value set by the parameter.	0 to 99.999 (mm)
8014	Delta-D	The value (d) commanded by D is used as the reference for the rough cutting cycle (G71, G72) cut amount, and $d - \Delta d$ , $d$ , $d + \Delta d$ are repeated. Cut change amount $\Delta d$ is set.	0 to 99.999 (mm)
8015	Pull up	This sets the amount of retraction when a return is made to the cutting start point in the rough cutting cycle (G71, G72).	0 to 99.999 (mm)

### 3.2 Setup Parameters

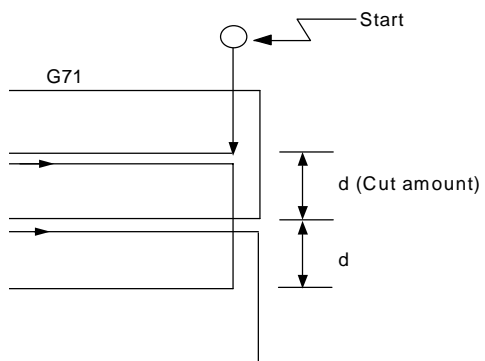
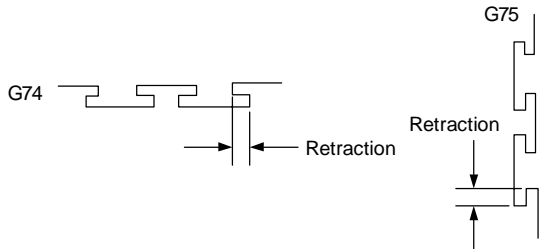
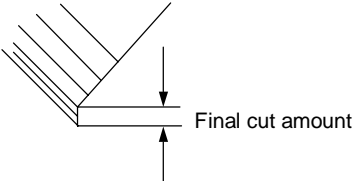
#	Item	Details	Setting range (unit)
8016	Thick	<p>This sets the cut amount in the rough cutting cycle (G71, G72).</p> 	0 to 99.999 (mm)
8017	G74 Retract	<p>This sets the chamfering amount (retraction) in the cut-off cycle (G74, G75).</p> 	0 to 99.999 (mm)
8018	G76 Finishing	<p>This sets the final cut amount in the compound thread cutting cycle (G76).</p> 	0 to 99.999 (mm)
8019	Minimum thick	<p>The minimum cut amount is used for cutting when the value is less than the minimum cut amount with constant cutting at the cut amount in the compound thread cutting cycle (G76). G code types 1 and 2 apply for the above G code.</p>	0 to 99.999 (mm)
8020	Times	<p>This sets the times the final cut amount (G76 Finishing) is divided in the compound thread cutting cycle (G76).</p>	0 to 99 (rev)
8021	Angle	<p>This sets the angle of the tool nose (thread angle) for the G76 command.</p>	0 to 99 (°)
8022	G71 Pocket	<p>This sets the pocket machining in the rough cutting cycle (G71, G72) finish program when there is a cavity (pocket).</p>	0: Pocket machining OFF 1: Pocket machining ON
8023	G73 CUT X	<p>This sets the X-axis cutting allowance in the formed rough cutting cycle (G73).</p>	0 to 99.999 (mm)
8024	CUT Z	<p>This sets the Z-axis cutting allowance for G73.</p>	0 to 99.999 (mm)
8025	Times	<p>This sets the number of G73 cutting passes.</p>	0 to 99999 (rev)

### 3.2 Setup Parameters

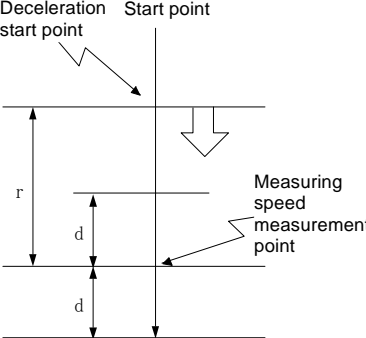
#	Item	Details	Setting range (unit)	
8026	G83 Retract	With the second and subsequent cutting passes in the deep hole drilling cycle (G83). This moves the tool by rapid traverse from the position machined immediately before by the amount equivalent to the setting, and then establishes cutting feed.	0 to 99.999 (mm)	
8027 to 8030				
8031	Tool wear max	This sets the maximum value check data in the input data when the tool wear data is set.	0 to 99.999 (mm)	
8032	inc max	This sets the maximum value check data in the input data when the tool wear data is added. <b>(Note)</b> When the setting is "0", the maximum value check is not performed.	0 to 99.999 (mm)	
8033	Auto TLM speed	[Automatic tool length measurement] 	This sets the feedrate for automatic tool length measurement.	1 to 60000 (mm/min)
8034	zone r		This sets the distance from the measurement point to the deceleration start point.	0 to 99999.999 (mm)
8035	zone d		This sets the area of the point where the tool should stop.	0 to 99999.999 (mm)
8051	Constant speed	This sets the speed constant in the program check operation function.	1 to 60000	
8052	Interval	This sets the frame feed time (from start up to pause) in the frame feed operation function.	0 to 9.9 (s)	

### 3.2 Setup Parameters

#	Item	Details	Setting range (unit)																																	
8053	Control*	<p>These are the parameters that select machine functions.</p> <table border="1" data-bbox="531 421 1067 499"> <tr> <td>7</td> <td>6</td> <td>5</td> <td>4</td> <td>3</td> <td>2</td> <td>1</td> <td>0</td> </tr> <tr> <td></td> <td></td> <td>VDEG</td> <td></td> <td>SGC</td> <td>THU</td> <td>LTC</td> <td></td> </tr> </table> <p>bit0: LTC (Linear type rotation axis function)            0: Invalid            1: Valid            [ This parameter is, however, valid when the Basic common parameter 2 "1328 sp_2 bit7" is set to 0 (common to systems). ]</p> <p>bit1: THU (High-precision thread cutting)            0: Invalid (normal thread cutting)            1: Valid            This is effective when the thread cutting is valid (chamfering is invalid) during thread cutting fixed cycle (G78) or compound thread cutting fixed cycle (G76).</p> <p>bit2: SGC            Select whether to change the servo gain of the related axis when the C axis is selected for the Spindle/C axis function.            0: Do not change the position loop gain.            1: Change the position loop gain.</p> <p>bit4, 5: VDEG (angle between vectors)            Set the angle between vectors for canceling the automatic insertion block during the nose R compensation mode.            If the angle between vectors is set to 0° (VDEG="00"), the automatic insertion block will be validated.            Normally, set this to "00".</p> <table border="1" data-bbox="572 1447 1058 1639"> <thead> <tr> <th colspan="2">VDEG</th> <th rowspan="2">Angle between vectors</th> </tr> <tr> <th>Bit5</th> <th>Bit4</th> </tr> </thead> <tbody> <tr> <td>0</td> <td>0</td> <td>0°</td> </tr> <tr> <td>0</td> <td>1</td> <td>2°</td> </tr> <tr> <td>1</td> <td>0</td> <td>4°</td> </tr> <tr> <td>1</td> <td>1</td> <td>8°</td> </tr> </tbody> </table> <p>bit3, bit6, bit7: Not used. Normally set to "0".</p>	7	6	5	4	3	2	1	0			VDEG		SGC	THU	LTC		VDEG		Angle between vectors	Bit5	Bit4	0	0	0°	0	1	2°	1	0	4°	1	1	8°	00 to FF (hexadecimal)
7	6	5	4	3	2	1	0																													
		VDEG		SGC	THU	LTC																														
VDEG		Angle between vectors																																		
Bit5	Bit4																																			
0	0	0°																																		
0	1	2°																																		
1	0	4°																																		
1	1	8°																																		
8055	Scrn saver time-out	Not used.	0																																	
8056	Intrf byps time-out	<p>This sets the time from axis stop to the time an interference alarm is output when the interfering object axis movement stops during interference bypass execution.            The interference alarm will not be output when the setting value is "0".</p>	0 to 255 (s)																																	

### 3.2 Setup Parameters

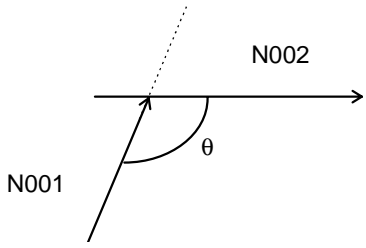
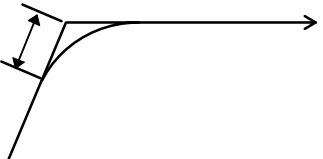
#	Item	Details	Setting range (unit)
8057	Corner check angle	<p>If the angle between blocks (inner angle) in automatic error detect is less than the set value, this judges a corner, and controls the start timing of the next block.</p>  <p>The diagram shows two blocks, N001 and N002, meeting at a corner. Block N001 is a line segment coming from the bottom-left towards the top-right. Block N002 is a horizontal line segment starting from the top-right end of N001 and extending to the right. A dashed line represents the extension of N001. The angle between the solid line of N001 and the solid line of N002 is labeled as theta (θ).</p>	0 to 180 (°)
8058	Corner check width	<p>After the block being executed has begun decelerating, this begins the next block if the position error amount of the command end point and the machine position is less than the set value.</p>  <p>The diagram shows a corner where a block is ending and another is beginning. A vertical double-headed arrow indicates the distance from the end of the first block to the start of the second block, representing the corner check width.</p>	0 to 99.999 (mm)
8059	Angle (G1 -> G0)	Not used.	0 to 180 (°)
8080	Counter selct invld*	This invalidates the display counter selection on the Monitor screen.	0, 1
8081	Test mode	This validates the Windows key.	0, 1
8082	Default menu	This selects the menu when the screen is selected. 0: Operation menu 1: Screen selection menu	0, 1
8083	Program save type	This selects the method for saving the program in the Edit screen. 0:The machining program is saved each time the <input type="button" value="INPUT"/> key is pressed. 1:The machining program is saved with the file save menu.	0, 1
8084	STN contrast	This adjusts the contrast of STN display.	0 to 15
8085	Space mode in editor	This selects the method of displaying the program on the Edit screen. 0: Display the texts as that was input. 1: Display with inserting a space between each word..	0, 1
8086	Invalid gray menu*	This shows or hides the menus that cannot be operated. 0: Display as gray menus. 1: Do not display.	0, 1

### 3.2 Setup Parameters

#	Item	Details	Setting range (unit)
8090	Graphic disp scale	Set the display scale used for drawing a path on the Graphic screen.	0 to 999.999
8091	disp mode	Set the display plane for drawing a path on the Graphic screen. <div style="display: flex; justify-content: space-around; border: 1px solid black; padding: 5px; margin: 10px 0;"> <div style="border: 1px solid black; padding: 2px;">                     0: Z-X plane                      1: Z-Y plane                      2: X-Z plane                      3: Z-Y plane                 </div> <div style="border: 1px solid black; padding: 2px;">                     4: Y-X plane                      5: Y-Z plane                      6: XYZ plane                 </div> </div>	0 to 6
8092	coord change	Designate the coordinate system used when drawing a path on the Graphic screen. 0: Machine position 1: Workpiece coordinate position	0, 1
8093	direct <I>	Set the magnification of the display scale for the X axis <sup>*1</sup> drawn on the Graphic screen. When a negative value is set, the drawing direction will reverse.	-128 to 127
8094	direct <J>	Set the magnification of the display scale for the Y axis <sup>*2</sup> drawn on the Graphic screen. When a negative value is set, the drawing direction will reverse.	-128 to 127
8095	direct <K>	Set the magnification of the display scale for the Z axis <sup>*3</sup> drawn on the Graphic screen. When a negative value is set, the drawing direction will reverse.	-128 to 127

\*1 Axis having command axis name that is the same as the axis name designated with the Setup parameter "8001 Plane <I>".

\*2 Axis having command axis name that is the same as the axis name designated with the Setup parameter "8002 Plane <J>".

\*3 Axis having command axis name that is the same as the axis name designated with the Setup parameter "8003 Plane <K>".



### 3.3 Input/Output Parameters

### 3.3 Input/Output Parameters

The necessary parameters are set when transferring files between differing devices. For parameters indicated with a "\*" in the table, turn the NC power OFF after setting. The setting is validated after the power is turned ON again.

#	Item	Details	Setting range (unit)
9001	Data input port No.	This sets the I/O port No. and device No. when each file of machining program, tool data, parameters, etc., is input from the external device to the NC memory.	<Port> 1 : Port 1 2 : Port 2 <Device> 1 : Device No. <1> to 5 : Device No. <5>
9002	Data input dev No.		
9003	Data output port No.		
9004	Data output dev No.		
9005	NC oper port No.	Not used.	<Port> 1 : Port 1 2 : Port 2 <Device> 1 : Device No. <1> to 5 : Device No. <5>
9006	NC oper dev No.		
9007	Macro print port No.	This sets the I/O port No. and device No. of the output device when carrying out an external output command in the user macro.	<Port> 1 : Port 1 2 : Port 2 <Device> 1 : Device No. <1> to 5 : Device No. <5>
9008	Macro print dev No.		
9101	Dev 1 name	This sets the device name corresponding to the device No. It is used to easily discriminate each device. <b>(Ex.)</b> PTR, PTP	Three characters (alphabetic, numeric and symbols) or less
9102	Dev 1 baud rate	This sets the data transfer speed.	300, 600, 1200, 2400, 4800, 9600, 19200 (bps)
9103	Dev 1 stop bit	This sets the stop bit length in the start stop method. The bit length is set matching the specifications of the input/output device. Refer to the item "9104 parity valid".	1 : 1 (bit) 2 : 1.5 3 : 2
9104	Dev 1 parity valid	This is the parameter when using a parity bit other than a data bit. It is set matching the specifications of the input/output device.	0 : No parity 1 : Parity
9105	Dev 1 even parity	This is the parameter that selects the odd or even parity when the parity above is valid. This parameter is ignored when the parity is invalid. It is set matching the specifications of the input/output device.	0 : Odd parity 1 : Even parity
9106	Dev 1 char length	This sets the data bit length. The character length (data bit) is set matching the specifications of the input/output device. Refer to the item "9104 parity valid".	0 : 5 bit 1 : 6 bit 2 : 7 bit 3 : 8 bit

### 3.3 Input/Output Parameters

#	Item	Details	Setting range (unit)																																
9107	Dev 1 termina type	The code that terminates the data reading can be selected.	0 : No terminator 1 : EOR or EOB 2 : EOB 3 : EOR 4 : One random character 5 : Two random characters																																
9108	Dev 1 termina code 1	This sets the code that terminates the reading when the "9107 termina type" setting is "4" or "5".	0 to FF (hexadecimal)																																
9109	Dev 1 termina code 2	This sets the code that terminates the reading when the "9107 termina type" setting is "5".	0 to FF (hexadecimal)																																
9110	Dev 1 hndshk method	This is an RS-232C transmission control method. It is set matching the control method of the input/output device to be connected.	1 : RTS/CTS 2 : No handshake 3 : DC code method																																
9111	Dev 1 DC code parity	This is only valid when "2" is selected in "9110 hndshk method". It is a parity addition for the DC code. It is set matching the specifications of the input/output device. <table border="1" style="margin-left: auto; margin-right: auto;"> <tr> <td></td> <td></td> <td>8</td> <td>7</td> <td>6</td> <td>5</td> <td>4</td> <td>3</td> <td>2</td> <td>1</td> <td></td> </tr> <tr> <td rowspan="2" style="text-align: center;">DC-3</td> <td style="text-align: center;">No parity</td> <td></td> <td></td> <td></td> <td style="text-align: center;">○</td> <td></td> <td></td> <td style="text-align: center;">○</td> <td style="text-align: center;">○</td> <td style="text-align: right;">(13H)</td> </tr> <tr> <td style="text-align: center;">Parity</td> <td style="text-align: center;">○</td> <td></td> <td></td> <td style="text-align: center;">○</td> <td></td> <td></td> <td style="text-align: center;">○</td> <td style="text-align: center;">○</td> <td style="text-align: right;">(93H)</td> </tr> </table>			8	7	6	5	4	3	2	1		DC-3	No parity				○			○	○	(13H)	Parity	○			○			○	○	(93H)	0 : No DC code parity 1 : Even code parity for DC codes
		8	7	6	5	4	3	2	1																										
DC-3	No parity				○			○	○	(13H)																									
	Parity	○			○			○	○	(93H)																									
9112	Dev 1 DC2/DC4 output	This is set when starting the output device with a DC code while transmitting data from the NC memory to the output device. It is set matching the specifications of the output device.	0 : DC2 invalid DC4 invalid 1 : DC2 valid DC4 invalid 2 : DC2 invalid DC4 valid 3 : DC2 valid DC4 valid																																
9113	Dev 1 CR output	During output with the ISO code, this is set when inserting a <CR> code immediately before the EOB (L/F) code.	0 : Invalid 1 : Valid																																
9114	Dev1 EIA output	During data output, this sets output by either the ISO code or EIA code. The ISO/EIA are automatically judged during data input.	0 : ISO output 1 : EIA output																																
9115	Dev 1 parity V	During data input into the NC memory, this is set when checking the parity V in one block.	0 : Invalid 1 : Valid																																
9116	Dev 1 timeout time	During data transfer, this set the timeout time that detects the interruption of the data transfer. An error occurs when the reading of one block or output time of 250 characters exceeds the designated time (timeout time), due to an input/output device fault or an exchange in the transmission. The timeout time setting must be changed depending on the baud rate.	0 to 999 (1/10s)																																

### 3.3 Input/Output Parameters

#	Item	Details	Setting range (unit)
9118	Dev 1 EIA code 1 [	<p>An alternate code can be designated for the codes at left that exist in the ISO but not in the EIA.</p> <p>Designate codes (odd-numbered codes) that do not duplicate preexisting EIA codes, and will not become parity H.</p> <p><b>(Note)</b> Do not designate the following codes: 0 to 9, A to Z, +, -, •, ', EOR, EOB, (,), BS, TAB, SP, &amp;, DEL, DC1 to DC4</p>	0 to FF
9119	Dev 1 EIA code 2 ]		
9120	Dev 1 EIA code 3 #		
9121	Dev 1 EIA code 4 *		
9122	Dev 1 EIA code 5 =		
9123	Dev 1 EIA code 6 :		
9124	Dev 1 printer type	This sets the type of printer to output to. (Valid for device name PTR.)	0 : Other than device name PTR 1 : Mitsubishi printer 2 : EPSON (ESC/P)
9125	Dev 1 feed number	This designates the length of the paper tape feed section (feed holes only) output before and after the data when outputting the tape. The length is set as a number of characters. The feed length is the same for both before and after the data.	0 to 999 (characters)
9126	Dev 1 rewind code	This sets the tape rewind code. Set the rewind code of the tape reader device being used. <b>(Note)</b> The tape will not rewind when "0" is set, even if the rewind command is executed.	0 to FF
9201 to 9226	Dev 2 parameters	Same as Dev 1.	Same as Dev 1.
9301 to 9326	Dev 3 parameters	Same as Dev 1.	Same as Dev 1.
9401 to 9426	Dev 4 parameters	Same as Dev 1.	Same as Dev 1.
9501 to 9526	Dev 5 parameters	Same as Dev 1.	Same as Dev 1.

### 3.3 Input/Output Parameters

#### 3.3.1 RS-232C I/O device parameter setting examples and cable connections

I/O device Parameter	Tape reader (Mitsubishi)		Tape puncher (Mitsubishi)	Printer (Mitsubishi)	Printer EPSON ESC/P support	Floppy disk (Kyoritsu)	Reader and puncher (Kyoritsu)	Floppy disk (Ricoh)	Floppy disk (Tanaka Business)	
	PTR-240	PTR-02A	PTP-02A	PRT-02A/B	VP135K	D-30	KRP-8250	FD-3.5	TBM-F1	
Device name										
Baud rate	4800	4800	4800	4800	9600	4800	4800	4800	4800	
Stop bit	1	3	3	3	1	3	3	3	3	
Parity valid	1	0	0	0	1	0	0	0	0	
Even parity	1	0	0	0	1	0	0	0	0	
Character length	3	3	3	3	3	3	3	3	3	
Terminator type	1	0	0	0	0	Input: 1 Output: 0	0	0	0	
Code 1	00	00	00	00	00	00	00	00	00	
Code 2	00	00	00	00	00	00	00	00	00	
Rewind code	0: Do not rewind 1: Rewind	0	0	0	0	0	0	0	0	
Handshake method	3	3	3	1	3	3	3	3	3	
DC code parity	1	1	1	0	0	1	0	1	1	
DC2/DC4 output	0	0	0	0	0	1	Puncher:1	0	1	
CR output	0	0	0	0/1	0	0	0	0	0	
EIA output	0	0	0/1	0/1	0	0	0/1	0/1	0/1	
No. of feeds	0	0	No. of characters	0	0	0	No. of characters	0	0	
Parity	0	0	0/1	0	0	0	0/1	0/1	0/1	
Timeout time	100	100	100	100	100	100	100	100		
Printer type										
Cable connection (enclosed cable)	NC 1 — 1 2 × 2 3 × 3 4) (4 5) (5 6) (6 20) (20 7 — 7	NC 1 — 1 2 × 2 3 × 3 4 × 4 5 × 5 6 × 6 20 × 20 7 — 7	NC 1 — 1 2 × 2 3 × 3 14 × 14 5 × 5 6 × 6 20 × 20 7 — 7	NC 1 — 1 2 × 2 3 × 3 14 × 14 5 × 5 6 × 6 20 × 20 7 — 7	NC 1 — 1 2 × 2 3 × 3 4 × 4 5 × 5 6 × 6 20 × 20 7 — 7	NC 1 — 1 2 × 2 3 × 3 4 × 4 5 × 5 6 × 6 20 × 20 7 — 7	NC 2 × 2 3 × 3 4 × 4 5 × 8 6 × 2 8 × 2 7 — 7	NC 2 × 1 3 × 10 4 × 5 5 × 11 6 × 2 8 × 2 20 × 12 7 — 7	NC 2 × 2 3 × 3 4 × 4 5 × 5 6 × 6 20 × 20 8 × 8	NC 2 × 2 3 × 3 4 × 4 5 × 5 6 × 6 20 × 20 8 × 8

### 3.4 Barrier Data

#### 3.4 Barrier Data

#	Item	Details	Setting range (unit)
8301	X	<p>Three points of chuck barrier or tailstock barrier can be set as parameters. These are set with the machine coordinate system.</p> <p>Points P1, P2 and P3 are for the chuck barrier, and points P4, P5 and P6 are for the tailstock barrier. The barrier range has a symmetrical shape in respect to the Z axis. If the barrier point P_ X axis coordinate is a minus value, the sign will be reversed to a positive sign, and the value will be calculated and checked. The absolute value of the X axis coordinate of each barrier point must be set in the following manner.</p> <p><math>P1 \geq P2 \geq P3, P4 \geq P5 \geq P6</math></p> <p>(Note that this does not apply for the Z axis.)</p>	±99999.999 (mm)
8302	Z		
8311	X		
8312	Z		
8321	X		
8322	Z		
8331	X		
8332	Z		
8341	X		
8342	Z		
8351	X		
8352	Z		

### 4. MACHINE PARAMETERS

A password is required to display or set the machine parameters. The methods of displaying the machine parameters, and the details of the parameters are explained in this chapter.

#### 4.1 Selecting the Machine Parameters

To set the machine parameters, enter the machine parameter setting mode with the following method. Refer to the Instruction Manual for details on general screen operations such as displaying and changing the menu and setting the parameters.

- (1) 

Display the menu related to setup.
------------------------------------

 ➔ The menu related to setup will appear.
  
- (2) 

Press the menu key	
<table border="1" data-bbox="277 869 475 902"><tr><td>Machine param</td></tr></table> .	Machine param
Machine param	

 ➔ A message prompting the password input will appear. If the password has been input once after the power was turned ON, the machine parameter menu will appear.
  
- (3) 

Set the password, and press the <table border="1" data-bbox="395 1025 485 1059"><tr><td>INPUT</td></tr></table> key.	INPUT
INPUT	
MPARA <table border="1" data-bbox="480 1084 569 1117"><tr><td>INPUT</td></tr></table>	INPUT
INPUT	

 ➔ The machine parameter menu will appear. Each screen can be selected from this menu.

## 4.2 Base Axis Parameters

### 4.2 Base Axis Parameters

For parameters indicated with a "\*" in the table, turn the NC power OFF after setting. The setting is validated after the power is turned ON again.

#	Item	Details	Setting range (unit)										
1001	axname	Name of axis Define correspondence between axis number and name.	X, Y, Z, U, V, W, A, B, C, etc., axis address										
1002	incax	Incremental command axis name Define axis name when incremental value commands are used. Valid when "ABS /INC address" is ON.											
1003	cunit	Command unit Set the minimum unit of the movement amount to be programmed for each axis.	<table border="1" style="width: 100%;"> <tr> <td style="text-align: center;">1</td> <td style="text-align: center;">0.1μm</td> </tr> <tr> <td style="text-align: center;">10</td> <td style="text-align: center;">1μm</td> </tr> <tr> <td style="text-align: center;">100</td> <td style="text-align: center;">10μm</td> </tr> <tr> <td style="text-align: center;">1000</td> <td style="text-align: center;">100μm</td> </tr> <tr> <td style="text-align: center;">10000</td> <td style="text-align: center;">1mm</td> </tr> </table>	1	0.1μm	10	1μm	100	10μm	1000	100μm	10000	1mm
1	0.1μm												
10	1μm												
100	10μm												
1000	100μm												
10000	1mm												
1004	sp_ax*	Spindle interpolation Define the spindle motor as the NC control axis. Spindle motor: Spindle/C-axis control Or, define the NC axis motor as the spindle.	0: Spindle control 1: Spindle and NC control axis 2: The NC axis motor is used as the spindle.										
1005	iout*	Inch output Define output unit as metric unit or inch unit. "1" is set when inch units are used for the detector system at the machine side (ball screw and detector).	0: mm 1: inch										
1006	rot*	Rotation axis Define whether axis is linear or rotation.	0: Linear axis 1: Rotation axis										
1007	ccw*	Motor ccw Define direction of motor rotation with forward direction command.	0: cw 1: ccw										
1008	svof*	Error correction Define whether error during servo OFF is to be corrected or not.	0: Error not corrected 1: Error corrected										
1009	dia	Diameter command Give the diameter command.	0: Radius value command 1: Diameter value command										
1010	polar*	Control axis relative polarity setting Set the system 1 axis to "0", and set the polarity of other system parallel axes in respect to the system 1 axis. When the parallel axes used for system 1 do not exist, set with consideration for the basic machine coordinate zero point setting values and polarity.	The polarity with the system 1 parallel axis is: 0: Positive 1: Negative										

## 4.2 Base Axis Parameters

#	Item	Details	Setting range (unit)									
1011	abson	Absolute position detection	With relative position detection system Define whether the soft limit is to be made valid or not after the power is turned ON until the completion of the reference point return.	Soft limit while reference point return in incomplete state is: 0: Invalid 1: Valid								
		Absolute position detection	With absolute position detection system Define whether absolute position detection is to be executed or not with absolute position detection system.	0: Absolute position detection invalid 1: Dog-type absolute position detection system 2: Dog-less type absolute position detection system								
1012	intabs	Manual ABS updating	Define whether absolute value data is to be updated or not during automatic handle interrupt.	0: No absolute values updated 1: Absolute values updated								
1013	axname 2	2nd axis name	Define the axis name for identifying the axis from all systems.	Set axis address such as X1, Z1 or C1 in 2 characters.								
1014	cross_\$	Cross axis designation	Set system to be used as cross axis. <table border="1" style="margin: 10px auto; text-align: center; width: 150px;"><tr><td>\$8</td><td>\$7</td><td>\$6</td><td>\$5</td><td>\$4</td><td>\$3</td><td>\$2</td><td>\$1</td></tr></table> <b>(Example)</b> "03" is the setting when this is used with systems 1 and 2.	\$8	\$7	\$6	\$5	\$4	\$3	\$2	\$1	00 to FF
\$8	\$7	\$6	\$5	\$4	\$3	\$2	\$1					
1015	axoff		Not used. Set to "0".	0								
1016	mcp_no *	MCP number	Define the MCP channel No. and its axis No. in two digits. <table border="1" style="margin: 10px auto; text-align: center; width: 150px;"><tr><td>Second digit</td><td>First digit</td></tr><tr><td>Channel No.</td><td>Axis No.</td></tr></table>	Second digit	First digit	Channel No.	Axis No.	11 to 17 21 to 27 31 to 37 41 to 47				
Second digit	First digit											
Channel No.	Axis No.											



### 4.3 Base System Parameters

### 4.3 Base System Parameters

For parameters indicated with a "\*" in the table, turn the NC power OFF after setting. The setting is validated after the power is turned ON again.

#	Item		Details	Setting range (unit)																																							
1101	Mfig	M number	Number: Set number which can be commanded in same block.  Binary: <table border="1" style="margin: 10px auto;"> <thead> <tr> <th>Data type</th> <th>Output data</th> </tr> </thead> <tbody> <tr> <td>0</td> <td>BCD</td> </tr> <tr> <td>1</td> <td>Binary (no sign)</td> </tr> <tr> <td>-1</td> <td>Binary (with sign)</td> </tr> </tbody> </table>	Data type	Output data	0	BCD	1	Binary (no sign)	-1	Binary (with sign)	1 to 4																															
Data type	Output data																																										
0	BCD																																										
1	Binary (no sign)																																										
-1	Binary (with sign)																																										
1102	Mbin	M binary		Data type (-1, 0, 1)																																							
1103	Sfig	S number	1 to 6																																								
1104	Sbin	S binary	Data type (-1, 0, 1)																																								
1105	Tfig	T number	1																																								
1106	Tbin	T binary	Data type (-1, 0, 1)																																								
1107	M2fig	2nd miscellaneous command number	"Sfig" sets not the number of same blocks but the number of spindles.	1																																							
1108	M2bin	2nd miscellaneous code binary		Data type (-1, 0, 1)																																							
1109	M2name	2nd miscellaneous code	Set address used as 2nd miscellaneous function. Select from among A, B, C codes not used for movement control axis.	A, B, C																																							
1110	skip_F	G31 skip rate	Set feedrate when F command is not contained in program when G31 or G160 command has been issued.	1 to 480000 (mm/min)																																							
1111	skip_C	G31 skip condition	The skip condition setting will skip to the next block during execution of the G31 command depending on which skip signal has been input.  For instance, when "7" has been set for the skip condition and any of skip 1 to 3 is input, it skips. (Equivalent to G31)	Skip condition: 0 to 7  <table border="1" style="margin: 10px auto;"> <thead> <tr> <th rowspan="2">Set-ting</th> <th colspan="3">PLC interface input signal</th> </tr> <tr> <th>3</th> <th>2</th> <th>Skip 1</th> </tr> </thead> <tbody> <tr><td>0</td><td>x</td><td>x</td><td>x</td></tr> <tr><td>1</td><td>x</td><td>x</td><td>0</td></tr> <tr><td>2</td><td>x</td><td>0</td><td>x</td></tr> <tr><td>3</td><td>x</td><td>0</td><td>0</td></tr> <tr><td>4</td><td>0</td><td>x</td><td>x</td></tr> <tr><td>5</td><td>0</td><td>x</td><td>0</td></tr> <tr><td>6</td><td>0</td><td>0</td><td>x</td></tr> <tr><td>7</td><td>0</td><td>0</td><td>0</td></tr> </tbody> </table>	Set-ting	PLC interface input signal			3	2	Skip 1	0	x	x	x	1	x	x	0	2	x	0	x	3	x	0	0	4	0	x	x	5	0	x	0	6	0	0	x	7	0	0	0
Set-ting	PLC interface input signal																																										
	3	2	Skip 1																																								
0	x	x	x																																								
1	x	x	0																																								
2	x	0	x																																								
3	x	0	0																																								
4	0	x	x																																								
5	0	x	0																																								
6	0	0	x																																								
7	0	0	0																																								
1112	extdcc	External deceleration speed	Upper limit of feedrate when external deceleration signal is valid.	1 to 480000 (mm/min)																																							
1113	tapovr		Not used. Set to "0".	0																																							
1114	thr_SF	Thread cutting speed	Set cutting speed for (chamfering) invalid with thread cutting cycle.	0 to 99999999 (0.001mm/rev) 0: Cutting feed clamp speed																																							
1115	tap_tl		Not used. Set to "0".	0																																							

### 4.3 Base System Parameters

#	Item	Details	Setting range (unit)																																								
1116	dwlskp	G04 skip condition	<p>This sets which skip signal should be input to skip to the next block during executing G04 command.</p> <p>For instance, when "7" has been set for the skip condition and any of skip 1 to 3 is input, it skips. (Equivalent to G31)</p> <table border="1" style="margin-left: auto; margin-right: auto;"> <thead> <tr> <th style="text-align: center;">Set-ting</th> <th colspan="3" style="text-align: center;">PLC interface input signal</th> </tr> <tr> <th style="text-align: center;"></th> <th style="text-align: center;">3</th> <th style="text-align: center;">2</th> <th style="text-align: center;">Skip 1</th> </tr> </thead> <tbody> <tr><td style="text-align: center;">0</td><td style="text-align: center;">×</td><td style="text-align: center;">×</td><td style="text-align: center;">×</td></tr> <tr><td style="text-align: center;">1</td><td style="text-align: center;">×</td><td style="text-align: center;">×</td><td style="text-align: center;">0</td></tr> <tr><td style="text-align: center;">2</td><td style="text-align: center;">×</td><td style="text-align: center;">0</td><td style="text-align: center;">×</td></tr> <tr><td style="text-align: center;">3</td><td style="text-align: center;">×</td><td style="text-align: center;">0</td><td style="text-align: center;">0</td></tr> <tr><td style="text-align: center;">4</td><td style="text-align: center;">0</td><td style="text-align: center;">×</td><td style="text-align: center;">×</td></tr> <tr><td style="text-align: center;">5</td><td style="text-align: center;">0</td><td style="text-align: center;">×</td><td style="text-align: center;">0</td></tr> <tr><td style="text-align: center;">6</td><td style="text-align: center;">0</td><td style="text-align: center;">0</td><td style="text-align: center;">×</td></tr> <tr><td style="text-align: center;">7</td><td style="text-align: center;">0</td><td style="text-align: center;">0</td><td style="text-align: center;">0</td></tr> </tbody> </table>	Set-ting	PLC interface input signal				3	2	Skip 1	0	×	×	×	1	×	×	0	2	×	0	×	3	×	0	0	4	0	×	×	5	0	×	0	6	0	0	×	7	0	0	0
Set-ting	PLC interface input signal																																										
	3	2	Skip 1																																								
0	×	×	×																																								
1	×	×	0																																								
2	×	0	×																																								
3	×	0	0																																								
4	0	×	×																																								
5	0	×	0																																								
6	0	0	×																																								
7	0	0	0																																								
1117	G96_ax	Constant surface speed axis	<p>Set which axis to exercise constant surface speed control when there is no P command in the G96 command block.</p> <p>When the constant surface speed axis parameter is set to 0, the first axis will be the constant surface speed axis regardless of whether the P command is issued or not.</p>																																								
			<p>0: P command invalid (fixed at 1st axis)</p> <p>1: 1st axis</p> <p>2: 2nd axis</p> <p>3: 3rd axis</p>																																								
1118	clmp_M	Clamp M code	<p>Set M code for C-axis clamping in hole drilling cycle.</p>																																								
1119	clmp_D	Dwell after unclamp M	<p>Set dwell time after outputting M code for C-axis unclamping in hole drilling cycle.</p>																																								
1120	origin	Origin zero prohibited (Not used.)	<p>Not used. Set to "0".</p>																																								
1121																																											
1122	mirofs	Double turret distance	<p>Set distance between tools (between tool noses) for double turret.</p>																																								
1123	TmirS1	Turret selection for T-command double turret	<p>Selects the turret for T-command double turret mirror image corresponding to Tool No.1 to 32.</p>																																								
1124	TmirS2	Turret selection for T-command double turret	<p>Selects the turret for T-command double turret mirror image corresponding to Tool No.33 to 64.</p>																																								
1125	mill_ax	Milling axis number	<p>Set rotation axis number providing milling interpolation.</p>																																								
1126	mill_C	Milling axis name	<p>Select the hypothetical axis name for milling.</p>																																								
1127 to 1130																																											
1131	Sselect	Initial spindle control selection	<p>Select the initial status after power has been turned ON.</p> <p>0: Spindle control mode (G43) ON</p> <p>1: 2nd spindle control mode (G44) ON</p>																																								
1132																																											

### 4.3 Base System Parameters

#	Item	Details	Setting range (unit)
1133 1134 1135 1136 1137	adr_abs [1] [2] [3] [4] [5]	Command address	Set the command address in the random axis change command in that system.  Axis address X, Y, Z, U, V, W, A, B, C, etc.
1138 1139 1140 1141 1142	adr_inc [1] [2] [3] [4] [5]	Incremental command address	Set the incremental command address for each command address used in the random axis change command.  Use only when the control parameter "#8106 ABS/INC Addr." is ON.  Axis address X, Y, Z, U, V, W, A, B, C, etc.
1143 1144 1145 1146 1147	base_ax [1] [2] [3] [4] [5]	Base configuration axis	Set the axis to control that system in the initial status.  X1, Z1, C1, etc., axis address set in two or less characters in the parameter axname2.
1149 1150 1151	real_I plane_I real_J _J real_K _K	Machine plane configuration axis	When there is a multi-system, set the axis name corresponding to the system common plane configuration axis direction, using the two-character axis name set in Base axis parameter "#1013 axname2".  X1, Z1, C1, etc. axis address set in two or less characters in the parameter axname2.

#### 4.4 Base Common Parameters

#### 4.4 Base Common Parameters

For parameters indicated with a "\*" in the table, turn the NC power OFF after setting. The setting is validated after the power is turned ON again.

#	Item	Details	Setting range (unit)	
1301	Mmac*	M call macro	Set whether macro call based on M command is to be executed or not when user macro specifications are valid.	0: Invalid 1: Valid
1302	Smac*	S call macro	Set whether macro call based on S command is to be executed or not when user macro specifications are valid.	0: Invalid 1: Valid
1303	Tmac*	T call macro	Set whether macro call based on T command is to be executed or not when user macro specifications are valid.	0: Invalid 1: Valid
1304	M2mac*	2nd miscellaneous code call macro	Set whether macro call is to be executed or not with 2nd miscellaneous command when user macro specifications are valid.	0: Invalid 1: Valid
1305	M_inch*	Constant inch input	Select unit used for machine parameter data.	0: mm 1: inch
1306	fix_P	Fixed cycle editing (Not used.)	Not used. Set to "0".	0
1307	edlk_C	Program lock C	Set "0" to input/output or edit the label number 9000 to 9999 machining programs. The data including the fixed cycle program will appear on the Data Input/Output screen, Edit screen and Program List, etc. Return the setting to "1" to input/output or edit a user machining program.	0: Invalid 1: Valid
1308	Pinc*	Machine error compensation amount incremental amount system	Designate incremental or absolute amount system for machine error compensation data setting.	0: Absolute amount system 1: Incremental amount system
1309	DPRINT	Arrangement of digit for DPRINT (Not used.)	Not used. Set to "0".	0
1310	ofsfix	Tool compensation No. fixed	Selects whether the #No. should be counted up by pressing [INPUT] key or not when tool compensation is set .	0: Counted up 1: Not counted up
1311	Tmiron	T command opposite turret mirror image selection	Selects whether the opposite turret minor image by T command is valid or not.	0: Invalid 1: Valid
1312	G96_G0	Rapid traverse control during constant surface speed	Select whether to calculate at all times constant surface speed for rapid traverse command or to calculate surface speed at end point of block.	0: Calculation at all times 1: Calculation at end point

#### 4.4 Base Common Parameters

#	Item	Details	Setting range (unit)	
1313	radius	Incremental command of diametrical designation axis	Select the diameter/radius value processing for incremental value command of the diametrical designation axis (dia (1) ).	0: Processing as diameter values 1: Processing as radius values
1314	Tldigt	Tool compensation number 1-digit command	The high-order digit of the T code indicates the tool number and the low-order digit indicates the tool compensation number. Select whether the number of digits designation is to be the two high-order and low-order digits or the three high-order and one low-order digit.	0: Low-order 2-digits for T code 1: Low-order 1-digit for T code
1315	Tlno.	Tool length offset number	Select whether tool length offset is to be applied by high-order or low-order digits of T code.	0: { High-order 2 or 3 digits of T code ... Tool number Low-order 2 or 1 digit of T code ... Tool length number/Tool wear number
				1: { High-order 2 or 3 digits of T code ... Tool number/Tool length number Low-order 2 or 1 digit of T code ... Tool wear number
1316	Treset	Tool offset amount cancel	This selects whether the tool length offset and wear offset vectors are to be cleared by resetting.	0: Cleared 1: Not cleared
1317	Tmove	Tool compensation operation	Select whether tool compensation is to be performed when a tool without a movement command is assigned.	0: Applied even for blocks without movement commands 1: Applied only for blocks without movement commands
1318	rstint*	Reset initialize	Define whether modals are to be initialized or not by reset button.	0: No reset initialize 1: Reset initialize
1319	I_abs*	Manual ABS parameter	Define by means of parameter using manual ABS switch whether absolute data is to be updated or not during manual, handle and automatic handle interrupt.	0: Based on manual ABS switch 1: Based on parameter
1320	H_acdc*	Handle time constant 0	Define whether time constant applying for handle feed is to be G01 time constant or time constant of 0.	0: Handle feed time constant G01 1: Handle feed time constant 0
1321	G30SL*	G30 soft limit invalid	Define whether soft limit is to be valid or not with G30 reference point return.	0: Soft limit valid with G30 1: Soft limit invalid with G30
1322	inpos*	In-position check valid	Define whether command deceleration check or in-position check will apply for deceleration check. If in-position check is selected, it checks by in-position width of servo parameter.	0: Command deceleration check method 1: In-position check method

#### 4.4 Base Common Parameters

#	Item	Details	Setting range (unit)																	
1323	tlm	Manual tool length measuring system	Select the method for carrying out manual tool length measurement 1. 0: Base point method (align tool to base position) 1: Measurement value input method (cut workpiece, and input measured results)	0: Reference point method(align tool to reference position) 1: Measurement value input method (cut workpiece, and input measure results)																
1324	lang	Display language changeover	Change the language to be displayed on the screen.	0: English 1: Japanese Followings: Not set																
1325	mirr_A	Opposite turret tool length setting system selection	Define whether value applying for tool of opposite turret is to be set as is or whether value applying for opposite turret tool in same direction at reference turret tool is to be set. 0: Value of opposite turret tool as it is 1: Value for tool on opposite turret which is value for same direction as tool of reference turret	0,1																
1326																				
1327	sp_1		This is the parameter that selects the function. <table border="1" style="margin-left: auto; margin-right: auto;"> <tr> <td style="text-align: center;">7</td> <td style="text-align: center;">6</td> <td style="text-align: center;">5</td> <td style="text-align: center;">4</td> <td style="text-align: center;">3</td> <td style="text-align: center;">2</td> <td style="text-align: center;">1</td> <td style="text-align: center;">0</td> </tr> <tr> <td style="width: 20px; height: 20px;"></td> <td style="width: 20px; height: 20px;"></td> <td style="width: 20px; height: 20px;"></td> <td style="width: 20px; height: 20px;"></td> <td style="width: 20px; height: 20px;"></td> <td style="width: 20px; height: 20px;"></td> <td style="width: 20px; height: 20px;"></td> <td style="width: 20px; height: 20px;"></td> </tr> </table> bit0: G1 in-position check valid 0: Command deceleration check method 1: In-position check method ( Define the deceleration check when in the cutting feed mode. During in-position check, it checks by the in-position width of the servo parameter. ) bit1: Rapid traverse constant inclination acceleration/deceleration valid 0: Rapid traverse time constant acceleration/deceleration system 1: Rapid traverse constant inclination acceleration/deceleration system ( Define the acceleration/deceleration system for the rapid traverse mode. Valid only in the linear acceleration/deceleration mode. ) bit2: G1 in-position check type 0: In-position check type A 1: In-position check type B ( Used to select the in-position check system for the G1 mode. ) bit3: G0 in-position check type 0: In-position check type A 1: In-position check type B ( Used to select the in-position check system for the G0 mode. )	7	6	5	4	3	2	1	0									00 to FF (HEX)
7	6	5	4	3	2	1	0													

#### 4.4 Base Common Parameters

#	Item	Details	Setting range (unit)																
		<p>bit4 : Tool command control            0: It always makes hand-shake (TF-FIN output) between NC and PLC when Tool command is assigned.            1: It makes hand-shake between NC and PLC only if a command of Tool No. exists in the Tool command.</p> <p><b>(Note)</b> Command of Tool No.            #1314 T1digit: 0 → The No. is more than high-order 3 digits of T-code value.            1 → The No. is more than high-order 2 digits of T-code value.</p> <p>bit5: Diameter command for manual random feed:            0: Moves regarding as a data fixed in radius value.            1: Moves following the machine parameter diameter/radius command.</p> <p>Bit7: Axis position monitor function validity            0: Do not monitor axis position (invalid)            1: Monitor axis position (valid)</p>																	
1328	sp_2	<p>This is the parameter that selects the function.</p> <table border="1" data-bbox="651 1104 1141 1187" style="margin-left: auto; margin-right: auto;"> <tr> <td style="text-align: center;">7</td> <td style="text-align: center;">6</td> <td style="text-align: center;">5</td> <td style="text-align: center;">4</td> <td style="text-align: center;">3</td> <td style="text-align: center;">2</td> <td style="text-align: center;">1</td> <td style="text-align: center;">0</td> </tr> <tr> <td style="width: 20px; height: 20px;"></td> <td style="width: 20px; height: 20px;"></td> <td style="width: 20px; height: 20px;"></td> <td style="width: 20px; height: 20px;"></td> <td style="width: 20px; height: 20px;"></td> <td style="width: 20px; height: 20px;"></td> <td style="width: 20px; height: 20px;"></td> <td style="width: 20px; height: 20px;"></td> </tr> </table> <p>bit2: Automatic change of spindle speed for thread cutting            0: Invalid (As commanded rotation)            1: Valid            This is available during "Thread cutting fixed cycle (G78) " or "Compound thread cutting fixed cycle (G76)"</p> <p>bit3: Spindle override during thread cutting            0: Spindle override invalid during thread cutting (fixed to 100%)            1: Spindle override valid during thread cutting</p> <p>bit7: Change of rotation axis (liner type/ rotation type)            0: Common on system            (According to "#8053 Control*" in the setup parameter.)            1: Axis independent            (According to "#2030 spx_1" in the axis specifications parameter.)</p>	7	6	5	4	3	2	1	0									00 to FF (HEX)
7	6	5	4	3	2	1	0												

#### 4.4 Base Common Parameters

#	Item	Details	Setting range (unit)																																
1329	sp_3	<p>This parameter selects the function.</p> <table border="1" data-bbox="608 360 1161 439"> <tr> <td>F</td><td>E</td><td>D</td><td>C</td><td>B</td><td>A</td><td>9</td><td>8</td><td>7</td><td>6</td><td>5</td><td>4</td><td>3</td><td>2</td><td>1</td><td>0</td> </tr> <tr> <td></td><td></td><td></td><td></td><td></td><td></td><td></td><td></td><td></td><td></td><td></td><td></td><td></td><td></td><td></td><td></td> </tr> </table> <p>bit2: Manual tool length measurement II wear data clear            0: Do not clear data (invalid)            1: Clear data (valid)</p> <p>bit4: Axis position monitor C function            0: Do not monitor axis position (invalid)            1: Monitor axis position (valid)</p> <p>bit6: Mirror image offset cancel            0: Hold            1: Cancel            • Select whether to cancel or hold the tool offset when mirror image is canceled.</p> <p>bit7: Manual speed clamp validity            0: The rapid traverse rate (#2001 rapid) is used for the maximum speed during jog, handle, incremental and manual zero point return (high-speed). However, the PLC device can be used to switch the maximum speed to the manual feed clamp speed (#2034 m_clamp).            1: The manual feed clamp speed (#2034 m_clamp) is used for the maximum speed during jog, handle, incremental and manual zero point return (high-speed).</p> <p>bit8: T command digits judgment            0: Function invalid            1: Function valid            • When the T macro call is valid, whether to call the T macro can be judged with the number of T digits.            • If the tool length offset No. and wear offset No. are individually commanded by parameter setting, the wear offset No. can be changed without changing the tool length offset No.            (Continued on the next page.)</p>	F	E	D	C	B	A	9	8	7	6	5	4	3	2	1	0																	0000 to FFFF (HEX)
F	E	D	C	B	A	9	8	7	6	5	4	3	2	1	0																				



#### 4.4 Base Common Parameters

#	Item	Details	Setting range (unit)
		<p>(Continued from the previous page.)</p> <p>bit9: Wear offset amount hold            0: Function invalid            1: Function valid</p> <ul style="list-style-type: none"> <li>• The tool length offset No. can be commanded while the wear offset No. is held with T<math>\Delta\Delta</math>97. (<math>\Delta\Delta</math> is a random tool length offset No.)</li> </ul> <p><b>(Note)</b> Each function can be used only when the high-order two digits of the T command are the tool length offset No., and the low-order two digits are the wear offset No.</p> <p>bitA to bitD: Use prohibited. (Used by system)            bitE: G53 tool compensation amount temporary cancel            0: Temporarily cancel            1: Do not temporarily cancel            bitF: Use prohibited. (Used by system)</p>	
1330	sp_4	<p>Thread cutting delay time:            Set delay time for thread cutting while high-precision thread cutting is valid (when control parameter/bit1 is ON).            Setting this time long can make the length of useful screw long. However, when the time is too long, thread cutting may rotate at the same height around the screw.</p> <p><b>(Note)</b> The value more than 255 can be set, but it is valid the quotient when the set value is divided by 256.</p>	0 to 255
1331	sp_5	<p>Error width of reach after auto-changing the spindle speed:            If it is effective auto-changing the thread cutting spindle speed (when sp_2/bit2 is ON) the thread cutting starts when the difference becomes smaller than this parameter value; the difference between the spindle commanded speed after auto-changing and the spindle axis actual speed.</p> <p><b>(Note)</b> The value more than 100 can be set, in such a case, it clamps at 100, but the display does not clamp.</p>	0 to 100 (r/min)

#### 4.4 Base Common Parameters

#	Item	Details	Setting range (unit)																
1332	sp_6	<p>This is the parameter that selects the function.</p> <table border="1" style="margin-left: auto; margin-right: auto;"> <tr> <td style="text-align: center;">7</td> <td style="text-align: center;">6</td> <td style="text-align: center;">5</td> <td style="text-align: center;">4</td> <td style="text-align: center;">3</td> <td style="text-align: center;">2</td> <td style="text-align: center;">1</td> <td style="text-align: center;">0</td> </tr> <tr> <td style="width: 20px; height: 20px;"></td> <td style="width: 20px; height: 20px;"></td> <td style="width: 20px; height: 20px;"></td> <td style="width: 20px; height: 20px;"></td> <td style="width: 20px; height: 20px;"></td> <td style="width: 20px; height: 20px;"></td> <td style="width: 20px; height: 20px;"></td> <td style="width: 20px; height: 20px;"></td> </tr> </table> <p>bit0: Subsystem start not possible alarm            0: When the subsystem start is not possible, waits until start is possible.            1: When the subsystem start is not possible, outputs an alarm.</p> <p>bit1: Use prohibited. (Used by system)</p> <p>bit2: When resetting, select Hold/Do not hold for the spindle clamp speed setting value.            0: Clears the spindle clamp speed when reset.            1: Does not clear the spindle clamp speed when reset.</p> <p>bit3: Select the valid range for the spindle clamp speed setting value.            0: Valid only during constant surface speed.            1: Valid for all spindle rotation commands.</p> <p>bit4: Continuous B→A transfer prohibited            0: Continuous B→A transfer is possible.            1: Continuous B→A transfer is prohibited.</p> <p>bit5: Use prohibited. (Used by system)</p> <p>bit6: Use prohibited. (Used by system)</p> <p>bit7: Use prohibited. (Used by system)</p>	7	6	5	4	3	2	1	0									00 to FF (HEX)
7	6	5	4	3	2	1	0												
1333	mstsyn	Dwell/MST override Valid/Invalid Select	Select whether the override is valid or not on the dwell/MST. (Multiple system)	0: Override invalid 1: Override valid															
1334	Tcom*	Offset common to systems	This selects whether the tool offset and tool life management are to apply in common to the systems or apply on a system-by-system basis.	0: System by system 1: Common to systems															
1335	syncch	Move command check with control axis synchronous	Select whether it makes axis moving command for synchronous axis invalid or an alarm when the command is assigned during the control axis are synchronous.	0: Invalid 1: Alarm															
1336	dspax*	Current value simultaneous display axis (Not used.)	Not used. Set to "0".	0															
1337	crsman*	Manual interrupt during cross machining	This selects whether manual interrupt is to be valid or invalid for the axis which has been crossed by the cross machining command.	0: Invalid 1: Valid															

#### 4.4 Base Common Parameters

#	Item	Details	Setting range (unit)
1338	otsys* Stop OT all systems Valid/invalid select	Select whether all systems will stop or only the system where the alarm occurred will stop when an H/W-OT, soft limit, or interference check alarm occurs. <b>(Note)</b> The system where the alarm occurred means the system that includes the superimposition (synchronization) and reference axis when the H/W-OT, soft limit, interference check alarm occurred during the superimposed/synchronized/random superimposed axis movement of the synchronous related axis.	0: System with error stops 1: All systems stop
1339			
1340	TGSmax Numbers of sets position control variables Numbers of packs in a set (Not used.)	Not used. Set to "0".	0
1341	H1_pno* No. 1 handle selection	Determine the port to which the No. 1 handle to No. 3 handle will be connected.	0: Port 0 1: Port 1 2: Port 2
1342	H2_pno* No. 2 handle selection		
1343	H3_pno* No. 3 handle selection		
1344	statio*	Not used. Set to "0".	0
1345	size-i*	Not used. Set to "0".	0
1346	size-o*	Not used. Set to "0".	0
1347	length*	Not used. Set to "0".	0
1348	b-rate*	Not used. Set to "0".	0
1349	s-bit*	Not used. Set to "0".	0
1350	parity*	Not used. Set to "0".	0
1351	even*	Not used. Set to "0".	0
1352	Tout-i	Not used. Set to "0".	0
1353	Tout-o*	Not used. Set to "0".	0
1354	siobus	Not used. Set to "0".	0
1355	cmacdb	Not used. Set to "0".	0

#### 4.4 Base Common Parameters

#	Item	Details	Setting range (unit)																																													
1356	GBtest	G/B spindle synchronous test mode  Set the test mode to register the characteristics of the reference spindle motor and the G/B spindle motor in the NC. When "1" is set in this parameter, the mode changes to the G/B spindle synchronous test mode. After setting this parameter, turn ON the G/B spindle synchronous signal, and forward or reverse run the reference spindle to the maximum speed, without passing the workpiece between the reference spindle and the G/B spindle. After the spindle rotation has stopped, always set "0" in this parameter.  Execute this function when the relative position error is large for the reference axis and the G/B spindle during constant speed rotation.	0: Normal 1: Test mode																																													
1357	Cool_t	Warning time during cooling (Not used.)	Not used. Set to "0".  0																																													
1358	SBSsys	Subsystem designation	Set the system to be used as the subsystem.  <table border="1" style="margin-left: auto; margin-right: auto;"> <tr> <td>\$1</td><td>\$2</td><td>\$3</td><td>\$4</td><td>\$5</td><td>\$6</td><td>\$7</td><td>\$8</td> </tr> </table>	\$1	\$2	\$3	\$4	\$5	\$6	\$7	\$8	00 to FF (HEX setting)																																				
\$1	\$2	\$3	\$4	\$5	\$6	\$7	\$8																																									
1359	SP2name	2nd spindle name	Set the spindle name (Snama) subject to 2nd spindle control. If 0, or spindle name except No.2 to No.6 is set, the spindle to be controlled will be the 2nd spindle. If the 1st spindle's name is set, the spindle to be controlled will be the 2nd spindle.	0 to 9																																												
1360	sp_7	This is the parameter that selects the function.  <table style="margin-left: auto; margin-right: auto;"> <tr> <td>F</td><td>E</td><td>D</td><td>C</td><td>B</td><td>A</td><td>9</td><td>8</td> </tr> <tr> <td style="border: 1px solid black; width: 20px; height: 20px;"></td> <td style="border: 1px solid black; width: 20px; height: 20px;"></td> <td style="border: 1px solid black; width: 20px; height: 20px;"></td> <td style="border: 1px solid black; width: 20px; height: 20px;"></td> <td style="border: 1px solid black; width: 20px; height: 20px;"></td> <td style="border: 1px solid black; width: 20px; height: 20px;"></td> <td style="border: 1px solid black; width: 20px; height: 20px;"></td> <td style="border: 1px solid black; width: 20px; height: 20px;"></td> </tr> <tr> <td>7</td><td>6</td><td>5</td><td>4</td><td>3</td><td>2</td><td>1</td><td>0</td> </tr> <tr> <td style="border: 1px solid black; width: 20px; height: 20px;"></td> <td style="border: 1px solid black; width: 20px; height: 20px;"></td> <td style="border: 1px solid black; width: 20px; height: 20px;"></td> <td style="border: 1px solid black; width: 20px; height: 20px;"></td> <td style="border: 1px solid black; width: 20px; height: 20px;"></td> <td style="border: 1px solid black; width: 20px; height: 20px;"></td> <td style="border: 1px solid black; width: 20px; height: 20px;"></td> <td style="border: 1px solid black; width: 20px; height: 20px;"></td> </tr> </table> bit0: C axis inch speed command method changeover 0: To not to change the speed command method for the rotation axis.  <table border="1" style="margin-left: auto; margin-right: auto;"> <thead> <tr> <th>Initial inch</th> <th>Mode</th> <th>Rotation axis speed</th> </tr> </thead> <tbody> <tr> <td rowspan="2" style="text-align: center;">OFF</td> <td style="text-align: center;">G21</td> <td style="text-align: center;">Command value</td> </tr> <tr> <td style="text-align: center;">G20</td> <td style="text-align: center;">Command value *25.4</td> </tr> <tr> <td rowspan="2" style="text-align: center;">ON</td> <td style="text-align: center;">G21</td> <td style="text-align: center;">Command value/25.4</td> </tr> <tr> <td style="text-align: center;">G20</td> <td style="text-align: center;">Command value *10</td> </tr> </tbody> </table> (Continued on the next page.)	F	E	D	C	B	A	9	8									7	6	5	4	3	2	1	0									Initial inch	Mode	Rotation axis speed	OFF	G21	Command value	G20	Command value *25.4	ON	G21	Command value/25.4	G20	Command value *10	00 to FF (HEX)
F	E	D	C	B	A	9	8																																									
7	6	5	4	3	2	1	0																																									
Initial inch	Mode	Rotation axis speed																																														
OFF	G21	Command value																																														
	G20	Command value *25.4																																														
ON	G21	Command value/25.4																																														
	G20	Command value *10																																														

#### 4.4 Base Common Parameters

#	Item	Details	Setting range (unit)													
		<p>(Continued from the previous page.)</p> <p>1: To change the speed command method</p> <table border="1"> <thead> <tr> <th>Initial inch</th> <th>Mode</th> <th>Rotation axis speed</th> </tr> </thead> <tbody> <tr> <td rowspan="2">OFF</td> <td>G21</td> <td>Command value</td> </tr> <tr> <td>G20</td> <td>Command value</td> </tr> <tr> <td rowspan="2">ON</td> <td>G21</td> <td>Command value</td> </tr> <tr> <td>G20</td> <td>Command value</td> </tr> </tbody> </table> <p>bit1: Spindle-type servo Spindle C axis Gain changeover selection during C axis selection            0: Do not change gain            1: Change gain</p> <p>Select whether to use the normal position loop gain (SV003, SV004, SV057) or the C axis/synchronous tap position loop gain (SV003, SV004, SV058) when the Spindle/C axis control is selected using spindle-type servo.</p> <p>bit2: Spindle-type servo Gain changeover selection during synchronous tapping            0: Do not change gain            1: Change gain</p> <p>Select whether to use the normal position loop gain (SV003, SV004, SV057) or the C axis/synchronous tap position loop gain (SV003, SV004, SV058) during synchronous tap control using the spindle-type servo.</p>	Initial inch	Mode	Rotation axis speed	OFF	G21	Command value	G20	Command value	ON	G21	Command value	G20	Command value	
Initial inch	Mode	Rotation axis speed														
OFF	G21	Command value														
	G20	Command value														
ON	G21	Command value														
	G20	Command value														
1401	M_type	<p>Used to select the operations of the M commands.</p> <p>0: Do not wait for the completion of registered M codes, but wait for the completion of other M codes.</p> <p>1: Wait for the completion of registered M codes, but do not wait for the completion of other M codes.</p>	0 to 1													
1402	S_mode	<p>Used to select the completion system for S commands.</p> <p>0: Wait for the completion signal from the PLC.</p> <p>1: Do not wait for the completion signal from the PLC.</p>	0 to 1													
1403	T_mode	<p>Used to select the completion system for T commands.</p> <p>0: Wait for the completion signal from the PLC.</p> <p>1: Do not wait for the completion signal from the PLC.</p>	0 to 1													

#### 4.4 Base Common Parameters

#	Item	Details	Setting range (unit)						
1404	M2_mode	<p>Used to select the completion system for second auxiliary commands.</p> <p>0: Wait for the completion signal from the PLC.</p> <p>1: Do not wait for the completion signal from the PLC.</p>	0 to 1						
1411 1412 1413 1414 1415 1416 1417 1418	M031-000 M063-032 M095-064 M127-096 M159-128 M191-160 M223-192 M255-224	<p>Used to register those M codes for which special operations are necessary. Set the M code number so that it corresponds to the bit number.</p> <p><b>(Example)</b> Registering M05 Register "00000020" in #1411.</p> <p>Care is required when setting as the operations of an M code change in accordance with the value in "M_type".</p> <table border="1" style="margin-left: auto; margin-right: auto; border-collapse: collapse;"> <thead> <tr> <th style="text-align: center;">Value of M_type</th> <th style="text-align: center;">Operations of an resistered M code</th> </tr> </thead> <tbody> <tr> <td style="text-align: center;">0</td> <td>Do not wait for completion signal from PLC.</td> </tr> <tr> <td style="text-align: center;">1</td> <td>Wait for completion signal from PLC.</td> </tr> </tbody> </table>	Value of M_type	Operations of an resistered M code	0	Do not wait for completion signal from PLC.	1	Wait for completion signal from PLC.	0 to FFFFFFFF HEX setting
Value of M_type	Operations of an resistered M code								
0	Do not wait for completion signal from PLC.								
1	Wait for completion signal from PLC.								

## 4.5 Axis Specification Parameters

### 4.5 Axis Specification Parameters

For parameters indicated with a "\*" in the table, turn the NC power OFF after setting. The setting is validated after the power is turned ON again.

#	Item	Details	Setting range (unit)																																																
2001	rapid	Rapid traverse rate	Set rapid traverse rate for each axis; maximum setting depends on machine system and so care is required in this respect.	1 to 480000 (mm/min)																																															
2002	clamp	Cutting feed clamp speed	Define maximum cutting feedrate for each axis.	1 to 480000 (mm/min)																																															
2003	smgst*	Acceleration/ deceleration mode	<p>Designate modes for acceleration/ deceleration control;</p> <table style="margin-left: 20px; border-collapse: collapse;"> <tr> <td style="padding: 2px;">F</td><td style="padding: 2px;">E</td><td style="padding: 2px;">D</td><td style="padding: 2px;">C</td><td style="padding: 2px;">B</td><td style="padding: 2px;">A</td><td style="padding: 2px;">9</td><td style="padding: 2px;">8</td><td style="padding: 2px;">7</td><td style="padding: 2px;">6</td><td style="padding: 2px;">5</td><td style="padding: 2px;">4</td><td style="padding: 2px;">3</td><td style="padding: 2px;">2</td><td style="padding: 2px;">1</td><td style="padding: 2px;">0</td> </tr> <tr> <td style="border: 1px solid black; width: 20px; height: 15px;"></td><td style="border: 1px solid black; width: 20px; height: 15px;"></td><td style="border: 1px solid black; width: 20px; height: 15px;"></td><td style="border: 1px solid black; width: 20px; height: 15px;"></td><td style="border: 1px solid black; width: 20px; height: 15px;"></td><td style="border: 1px solid black; width: 20px; height: 15px;"></td><td style="border: 1px solid black; width: 20px; height: 15px; text-align: center;">OT3</td><td style="border: 1px solid black; width: 20px; height: 15px; text-align: center;">OT2</td><td style="border: 1px solid black; width: 20px; height: 15px; text-align: center;">OT1</td><td style="border: 1px solid black; width: 20px; height: 15px; text-align: center;">C3</td><td style="border: 1px solid black; width: 20px; height: 15px; text-align: center;">C1</td><td style="border: 1px solid black; width: 20px; height: 15px; text-align: center;">LC</td><td style="border: 1px solid black; width: 20px; height: 15px; text-align: center;">R3</td><td style="border: 1px solid black; width: 20px; height: 15px; text-align: center;">R1</td><td style="border: 1px solid black; width: 20px; height: 15px; text-align: center;">LR</td> </tr> </table> <p><b>(Note)</b> Always set blank bits to "0".</p> <p><b>Rapid traverse acceleration/ deceleration type</b></p> <table style="margin-left: 20px; border-collapse: collapse;"> <tr> <td style="border: 1px solid black; padding: 2px;">LR=1 R1, R3=0</td> <td style="border: 1px solid black; padding: 2px;">Linear acceleration, linear deceleration</td> </tr> <tr> <td style="border: 1px solid black; padding: 2px;">R1=1 LR, R3=0</td> <td style="border: 1px solid black; padding: 2px;">Primary delay</td> </tr> <tr> <td style="border: 1px solid black; padding: 2px;">R3=1 LR, R1=0</td> <td style="border: 1px solid black; padding: 2px;">Exponential/function acceleration, linear deceleration</td> </tr> <tr> <td style="border: 1px solid black; padding: 2px;">LR=R1=R3=0</td> <td style="border: 1px solid black; padding: 2px;">Step</td> </tr> </table> <p><b>(Note)</b> Do not set more than one of LR, R1, R3 to "1".</p> <p><b>Cutting feed acceleration/ deceleration type</b></p> <table style="margin-left: 20px; border-collapse: collapse;"> <tr> <td style="border: 1px solid black; padding: 2px;">LC=1 C1, C3=0</td> <td style="border: 1px solid black; padding: 2px;">Linear acceleration, linear deceleration</td> </tr> <tr> <td style="border: 1px solid black; padding: 2px;">C1=1 LC, C3=0</td> <td style="border: 1px solid black; padding: 2px;">Primary delay</td> </tr> <tr> <td style="border: 1px solid black; padding: 2px;">C3=1 LC, C1=0</td> <td style="border: 1px solid black; padding: 2px;">Exponential/function acceleration, linear deceleration</td> </tr> <tr> <td style="border: 1px solid black; padding: 2px;">LC=C1=C3=0</td> <td style="border: 1px solid black; padding: 2px;">Step</td> </tr> </table> <p><b>(Note)</b> Do not set more than one of LC, C1, C3 to "1".</p>	F	E	D	C	B	A	9	8	7	6	5	4	3	2	1	0							OT3	OT2	OT1	C3	C1	LC	R3	R1	LR	LR=1 R1, R3=0	Linear acceleration, linear deceleration	R1=1 LR, R3=0	Primary delay	R3=1 LR, R1=0	Exponential/function acceleration, linear deceleration	LR=R1=R3=0	Step	LC=1 C1, C3=0	Linear acceleration, linear deceleration	C1=1 LC, C3=0	Primary delay	C3=1 LC, C1=0	Exponential/function acceleration, linear deceleration	LC=C1=C3=0	Step	HEX setting
F	E	D	C	B	A	9	8	7	6	5	4	3	2	1	0																																				
						OT3	OT2	OT1	C3	C1	LC	R3	R1	LR																																					
LR=1 R1, R3=0	Linear acceleration, linear deceleration																																																		
R1=1 LR, R3=0	Primary delay																																																		
R3=1 LR, R1=0	Exponential/function acceleration, linear deceleration																																																		
LR=R1=R3=0	Step																																																		
LC=1 C1, C3=0	Linear acceleration, linear deceleration																																																		
C1=1 LC, C3=0	Primary delay																																																		
C3=1 LC, C1=0	Exponential/function acceleration, linear deceleration																																																		
LC=C1=C3=0	Step																																																		

### 4.5 Axis Specification Parameters

#	Item	Details	Setting range (unit)																					
		<p><b>&lt;Acceleration/deceleration pattern combination&gt;</b></p> <p><b>&lt;Stroke end stop type&gt;</b></p> <table border="1" style="margin-left: auto; margin-right: auto;"> <thead> <tr> <th>Type</th> <th>OT2</th> <th>OT3</th> </tr> </thead> <tbody> <tr> <td>Linear deceleration</td> <td style="text-align: center;">0</td> <td style="text-align: center;">0</td> </tr> <tr> <td>Position loop step stop</td> <td style="text-align: center;">1</td> <td style="text-align: center;">0</td> </tr> <tr> <td>Speed loop step stop</td> <td style="text-align: center;">0</td> <td style="text-align: center;">1</td> </tr> <tr> <td>Position loop step stop</td> <td style="text-align: center;">1</td> <td style="text-align: center;">1</td> </tr> </tbody> </table> <table border="1" style="margin-left: auto; margin-right: auto;"> <thead> <tr> <th>OT1</th> <th>0</th> <th>Deceleration with G0t1</th> </tr> </thead> <tbody> <tr> <th>OT1</th> <th>1</th> <th>Deceleration with 2 × Gt01</th> </tr> </tbody> </table> <p>OT1 is valid when stop type is "linear deceleration" and acceleration/deceleration mode is "exponential acceleration/linear deceleration". (It is also valid with dog-type zero point return.)</p>	Type	OT2	OT3	Linear deceleration	0	0	Position loop step stop	1	0	Speed loop step stop	0	1	Position loop step stop	1	1	OT1	0	Deceleration with G0t1	OT1	1	Deceleration with 2 × Gt01	
Type	OT2	OT3																						
Linear deceleration	0	0																						
Position loop step stop	1	0																						
Speed loop step stop	0	1																						
Position loop step stop	1	1																						
OT1	0	Deceleration with G0t1																						
OT1	1	Deceleration with 2 × Gt01																						
2004	G0tL	G0 time constant (linear)	1 to 1500 (ms)																					
		<p>Set time constant for linear control with rapid traverse acceleration/deceleration; valid when linear acceleration/linear deceleration rapid traverse (LR) has been selected in acceleration/deceleration mode "#2003 smgst"</p>																						

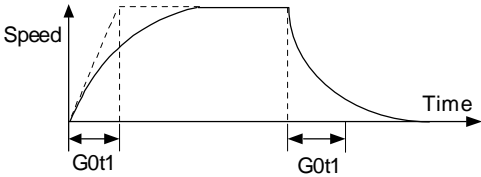
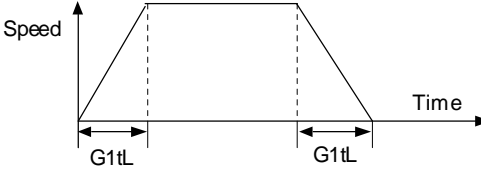
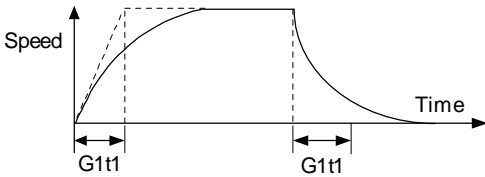

#### 4.5 Axis Specification Parameters

#	Item	Details	Setting range (unit)
2005	G0t1	<p>G0 time constant (primary delay)</p> <p>Set primary delay time constant with rapid traverse acceleration/deceleration; valid when primary delay rapid traverse (R1) and exponential acceleration/linear deceleration rapid traverse (R3) have been selected in acceleration/deceleration mode "#2003 smgst".</p> <p><b>&lt;Primary delay rapid traverse&gt;</b></p> 	1 to 5000 (ms)
2006	G0t2	Not used. Set to "0".	0
2007	G1tL	<p>G1 time constant (linear)</p> <p>Set time constant for linear control with cutting feed acceleration/deceleration; valid when linear acceleration/linear deceleration cutting feed has been selected in acceleration/deceleration mode "#2003 smgst".</p> 	1 to 1500 (ms)
2008	G1t1	<p>G1 time constant (primary delay)</p> <p>Set primary delay time constant with cutting feed acceleration/deceleration; valid when primary delay cutting feed (C1) and exponential acceleration/linear deceleration cutting feed (C3) have been selected in acceleration/deceleration mode "#2003 smgst".</p> <p><b>&lt;Primary delay cutting feed&gt;</b></p> 	1 to 5000 (ms)
2009	G1t2	Not used. Set to "0".	0
2010	OTtm	<p>OT time</p> <p>When the speed loop step stop is selected for the Stroke end stop type, it keeps the speed loop state during the time set. Set the same or near value as the G0 time constant.</p>	1 to 32767 (ms)

#### 4.5 Axis Specification Parameters

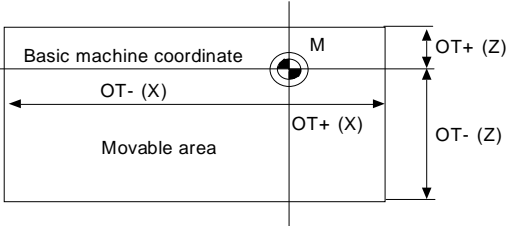
#	Item	Details	Setting range (unit)	
2011	G0back	G0 backlash	Set backlash compensation amount with movement command in rapid traverse mode or with reverse direction in manual mode.	–9999 to 9999 (command unit/2)
2012	G1back	G1 backlash	Set backlash compensation amount with reverse direction when movement command has been issued in cutting feed mode.	–9999 to 9999 (command unit/2)
2013	OT–	Soft limit –	<p>These set soft limit area with zero point of basic machine coordinate system as reference point.</p> 	±99999.999 (mm)
2014	OT+	Soft limit +		
2015	t1ml–	Manual tool length measurement II – direction sensor	This sets the – direction sensor position when the manual tool length measurement II is used.	±99999.999 (mm)
2016	t1ml+	Manual tool length measurement II + direction sensor	This sets the + direction sensor position when the manual tool length measurement II is used.	±99999.999 (mm)
2017	pG0t	G0 time constant during superimposing	This sets the time constant with rapid traverse acceleration/deceleration during superimposing.	1 to 750 (ms)
2018	pG1t	G1 time constant during superimposing	This sets the time constant with cutting feed acceleration/deceleration during superimposing.	1 to 5000 (ms)
2019				
2020				
2021	plrap0	Rapid traverse rate 0 during superimposing	In the superimpose command, this sets the rapid traverse rate with movement in the same direction as another axis which is moving by rapid traverse.	1 to 480000 (mm/min)
2022	plrap1	Rapid traverse rate 1 during superimposing	In the superimpose command, this sets the rapid traverse rate with movement in the same direction as another axis which is moving by cutting feed.	1 to 480000 (mm/min)
2023	plclmp	Cutting feed clamp speed	In the superimpose command, this sets the cutting feed clamp speed with movement in the same direction as another axis which is moving by cutting feed.	1 to 480000 (mm/min)

## 4.5 Axis Specification Parameters

#	Item	Details	Setting range (unit)																	
2024	offset	Tool offset select (Not used.)	Not used. Set to "0".	0																
2025	G0fwdg	G0 feed forward gain	Set the feed forward gain value for rapid traverse mode (G0) in automatic operations.	0 to 200 (%) Standard value: 70 (%)																
2026	fwd_g	G1 feed forward gain	Set feed forward gain for cutting feed mode (G1, G2, G3) in automatic operation.	0 to 200 (%) Standard value: 70 (%)																
2027	vir_ax	Hypothetical axis	Set whether the axis is treated as hypothetical axis or not.	0: Not treated as hypothetical axis 1: Treated as hypothetical axis																
2028	ref-	Reference point approach-	Assign the -side and +side with the first reference point as a standard point. The reference point approach signal is output within the setting range for each of positive or negative side with the first reference point as a standard point.	0 to 179.999 (mm)																
2029	ref+	Reference point approach+																		
2030	spx_1	Rotation axis type select linear type/ rotation type	<table border="1" style="margin-left: auto; margin-right: auto;"> <tr> <td style="text-align: center;">7</td> <td style="text-align: center;">6</td> <td style="text-align: center;">5</td> <td style="text-align: center;">4</td> <td style="text-align: center;">3</td> <td style="text-align: center;">2</td> <td style="text-align: center;">1</td> <td style="text-align: center;">0</td> </tr> <tr> <td style="width: 20px; height: 20px;"></td> <td style="width: 20px; height: 20px;"></td> <td style="width: 20px; height: 20px;"></td> <td style="width: 20px; height: 20px;"></td> <td style="width: 20px; height: 20px;"></td> <td style="width: 20px; height: 20px;"></td> <td style="width: 20px; height: 20px;"></td> <td style="width: 20px; height: 20px; text-align: center;">LTC</td> </tr> </table> <p>bit0: LTC (Linear type rotation axis function) (PR) 0: Invalid 1: Valid</p> <p style="text-align: center;">( This parameter is, however, effective when "#1328 sp_2 bit7" has been set to 1 (axis independent). )</p> <p>bit1 to bit7: Not used. Normally set to 0.</p>	7	6	5	4	3	2	1	0								LTC	00 to FF (HEX)
7	6	5	4	3	2	1	0													
							LTC													
2031	spx_2		Not used. Set to "0".	00																
2032	spx_3		Not used. Set to "0".	0000																

### 4.5 Axis Specification Parameters

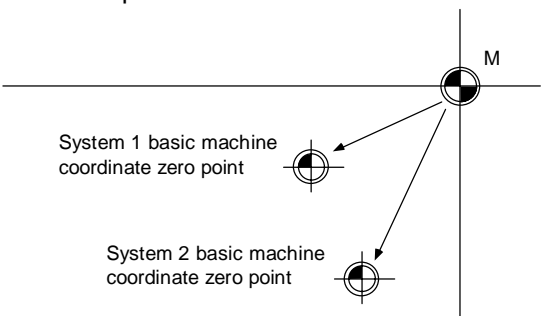
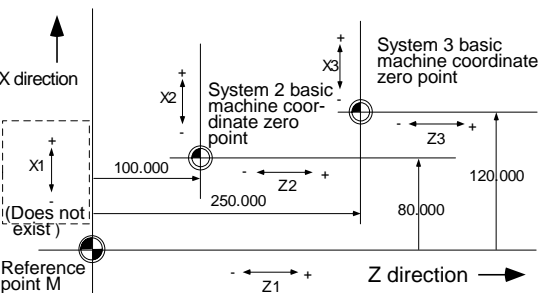
#	Item	Details	Setting range (unit)
2033	baseps	<p>Basic machine coordinate zero point relative distance</p>	<p>Set each axis position of the basic machine coordinate zero point having the random reference point M on the machine as a reference point.</p>  <p>Align the machine zero point position direction of all systems with the direction of the first system machine coordinate system direction. When there is no parallel axis used for the first system, randomly decide the direction.</p> <p>#1010 polar/#2033 baseps setting example            System 1: Z1            System 2: X2, Z2            System 3: X3, Z3            The following concerns the polar/baseps setting method of the axis configuration above.</p>  <p>(system 1 basic machine coordinate zero point)</p>
2034	m_clamp	Manual feed clamp speed	<p>Set the maximum speed for each axis when manual clamp is valid. If "0" is set, the rapid traverse rate (#2001 rapid) will be applied.</p>

## 4.6 Zero (Reference) Point Return Parameters

### 4.6 Zero (Reference) Point Return Parameters

For parameters indicated with a "\*" in the table, turn the NC power OFF after setting. The setting is validated after the power is turned ON again.

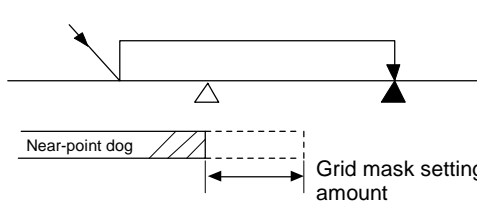
#	Item	Details	Setting range (unit)
2101	G28rap	G28 rapid traverse rate  Set dog-type rapid traverse rate for reference point return command.  For automatic dog-less type, set the reference point return speed after the absolute position is established.	1 to 480000 (mm/min)
2102	G28crp	G28 approach speed  Define approach speed to reference point after deceleration and stop by dog detection for reference point return command.  For automatic dog-less type, set the speed to establish the absolute position after the second push.	1 to 480000 (mm/min)
2103	G28sft	Reference point shift amount  Define distances from electrical zero point detection position to actual machine reference point for reference point return control.	0 to 65535 (μm)
2104	grspc	Grid interval  Set the grid interval value for detector. In common practices, the setting of detector grid interval should be identical to that of ball screw pitch. In case that the detector grid interval and the screw pitch are different for linear scaling, set the detector grid interval value.  Also, when reducing a grid interval value, use a common divisor of grid interval.	0 to 32767 (mm)
2105	grmask	Grid mask amount  Set intervals where grid points are ignored when near-point dog OFF signal is near-grid point during reference point return.   Effective range of grid mask is distance equivalent to 1 grid.	0 to 65535 (μm) Also set the submicron meter specifications in (μm) units.

### 4.6 Zero (Reference) Point Return Parameters

#	Item	Details	Setting range (unit)
2106			
2107	dir (-)*	<p>Reference point direction (-)</p> <p>Set (-) or (+) direction from near-point dog for reference point position.</p> <p><b>&lt;For a dog-type reference point return&gt;</b> Looking from the near-point, in the direction establishing the zero point.</p> <p><b>&lt;For a dog-less reference point return&gt;</b> (when base=0) Looking from the stopper point, in the direction of the grid point that establishes the absolute position</p>	0: Positive direction 1: Negative direction
2108	noref	<p>Axis without reference point</p> <p>Designate for axis without reference point; reference point return is not necessary prior to automatic operation.</p>	0: Normal control axis 1: Axis without reference point

#### 4.6 Zero (Reference) Point Return Parameters

#	Item	Details	Setting range (unit)																	
2109	Z_pulse	Spindle encoder Z-phase pulse method (Not used.)	0																	
2110	nochk	No completion check of reference point return (Not used.)	0																	
2111 to 2112																				
2113 2114 2115 2116	#1_rfp #2_rfp #3_rfp #4_rfp	<p>#1 to #4 reference points</p> <p>Set positions of 1st, 2nd, 3rd and 4th reference points with basic machine coordinate zero point as reference points.</p> <div style="text-align: center;"> <p>The diagram shows a coordinate system with a horizontal axis labeled 'Basic machine coordinates' and a vertical axis labeled 'M'. The origin 'M' is at the top right. Four reference points are marked with circles and labeled #1, #2, #3, and #4. Arrows point from the origin 'M' to each of these reference points, indicating their relative positions.</p> </div> <p>Using the PLC signal (Y200, Y201), the return position for dog-less type reference point return can be selected from the 1st to 4th reference point.</p> <p><b>(Example)</b></p> <table border="1" style="margin-left: auto; margin-right: auto; border-collapse: collapse;"> <thead> <tr> <th colspan="2">PLC signal (\$1)</th> <th rowspan="2">Return position</th> </tr> <tr> <th>Y200</th> <th>Y201</th> </tr> </thead> <tbody> <tr> <td>0</td> <td>0</td> <td>1st reference point</td> </tr> <tr> <td>1</td> <td>0</td> <td>2nd reference point</td> </tr> <tr> <td>0</td> <td>1</td> <td>3rd reference point</td> </tr> <tr> <td>1</td> <td>1</td> <td>4th reference point</td> </tr> </tbody> </table> <p><b>(Note)</b> The selected signal is validated by saving the state when started, so the setting cannot be changed during operation.</p>	PLC signal (\$1)		Return position	Y200	Y201	0	0	1st reference point	1	0	2nd reference point	0	1	3rd reference point	1	1	4th reference point	±999999.999 (mm)
PLC signal (\$1)		Return position																		
Y200	Y201																			
0	0	1st reference point																		
1	0	2nd reference point																		
0	1	3rd reference point																		
1	1	4th reference point																		

## 4.7 Servo Parameters

### 4.7 Servo Parameters

The parameters can be changed from any screen.

**(Note)** In the following explanations on bits, set all bits not used, including blank bits, to "0".

The valid servo parameters differ according to the motor type. The setting values and meanings may also differ. Follow the tables given below, and set the correct parameters.

Refer to each Instruction Manual or the following manuals for details on each motor.

MELDAS AC Servo/ Spindle	MDS-A Series MDS-B Series Specification Manual.....BNP-B3759	
MELDAS AC Servo	MDS-B-Vx Series Servo Parameter Instruction Manual.....BNP-A2993	
MELDAS AC Servo	MR-SVJ2 Series Specification and Instruction Manual.....BNP-B3937	

○: Valid    Δ: Differs according to each bit. Follow the explanations on the following pages.

Parameter	Corresponding model		
	MDS-B-V1/V2	MDS-B-SVJ2	HS series
SV001	○	○	○
SV002	○	○	○
SV003	○	○	○
SV004	○	○	○
SV005	○	○	○
SV006	○	–	–
SV007	○	–	–
SV008	○	○	○
SV009	○	○	○
SV010	○	○	○
SV011	○	○	○
SV012	○	○	○
SV013	○	○	○
SV014	○	○	○
SV015	○	○	○
SV016	○	○	○
SV017	○	Δ	Δ
SV018	○	○	○
SV019	○	○	○
SV020	○	○	○
SV021	○	○	○
SV022	○	○	○
SV023	○	○	○
SV024	○	○	○
SV025	○	○	○
SV026	○	○	○
SV027	○	Δ	Δ
SV028	–	–	–
SV029	○	–	–
SV030	○	–	○
SV031	○	○	○
SV032	○	○	○

Parameter	Corresponding model		
	MDS-B-V1/V2	MDS-B-SVJ2	HS series
SV033	○	Δ	Δ
SV034	○	Δ	Δ
SV035	○	–	○
SV036	○	○	○
SV037	○	○	○
SV038	○	○	○
SV039	○	○	○
SV040	○	Δ	○
SV041	○	○	○
SV042	○	○	○
SV043	○	○	○
SV044	○	○	○
SV045	○	–	○
SV046	–	–	–
SV047	○	○	○
SV048	○	○	–
SV049	○	○	○
SV050	○	○	○
SV051	○	–	–
SV052	○	–	–
SV053	○	○	○
SV054	○	–	○
SV055	○	–	–
SV056	○	○	○
SV057	○	○	○
SV058	○	○	○
SV059	○	–	○
SV060	○	–	○
SV061	○	○	○
SV062	○	○	–
SV063	○	○	○
SV064	○	○	–



**4.7 Servo Parameters**  
**4.7.1 Servo Parameters**

**4.7.1 Servo Parameters**

For parameters marked with an "\*" in the table, turn the NC power OFF after setting. After the power is turned ON again, the parameter is validated.

No.	Item			Details	Setting range (unit)
2201	SV001	PC1*	Motor gear ratio	<p><b>When using spindle-type servo Spindle C axis</b></p> <p>Set PC1 and PC2 to the smallest integer ratio.</p>	1 to 30 for both PC1 and PC2
2202	SV002	PC2*	Machine gear ratio	<p>Set the spindle-type servo parameters (spindle PC1, spindle PC2, spindle PIT) and the servo parameters (C axis PC1, C axis PC2, C axis PIT) to satisfy the following conditions:</p> $[C \text{ axis PC1}] \times [\text{spindle PC2}] \times [\text{spindle PIT}] = A$ $[\text{Spindle PC1}] \times [C \text{ axis PC2}] \times [C \text{ axis PIT}] = B$ <p>Set so that the smallest integer ratio of A and B is 32767 or less.</p> <p><b>For other cases</b></p> <p>Set the gear ratio between motor side and machine side.</p> <p>For a rotation axis, set the total deceleration (acceleration) ratio.</p> <p>Even if the gear ratio is within the setting range, the electronic gears could overflow causing an alarm.</p>	
2203	SV003	PGN1	Position loop gain 1	<p>Set the position loop gain in increments of "1".</p> <p>Set "33" for normal operation.</p> <p>For SHG control, set both SV004 (PGN2) and SV057 (SHGC). (When using MDS-B-SVJ2.)</p>	1 to 200 (1/s)
2204	SV004	PGN2	Position loop gain 2	<p>For SHG control, set this parameter with SV003 (PGN1), SV057 (SHGC). (When using MDS-B-SVJ2.)</p> <p>Set "0" when it is not used.</p>	0 to 999 (1/s)
2205	SV005	VGN1	Speed loop gain 1	<p>Set the speed loop gain.</p> <p>The standard value is 150.</p> <p>When it is increased, response is improved but vibration and sound become larger.</p>	1 to 999
2206	SV006	VGN2	Speed loop gain 2	<p>If it is desired to reduce noise generated at high-speed rotation for rapid traverse, set a speed loop gain (smaller than VGN1) to be gain at high-speed rotation (1.2 times higher than the rated rotating speed).</p> <p>Set this parameter in combination with SV029 (VCS), which is start speed of speed gain decrease.</p> <p>Set "0" when this parameter function is not used.</p> <div style="text-align: center;"> </div>	-1000 to 1000
2207	SV007	VIL	Speed loop delay compensation	<p>Set this parameter when the limit cycle occurs in a closed loop, or the overshoot occurs during positioning.</p> <p>Set "0" to invalidate speed loop delay compensation.</p> <p>Related parameter is SV027 (bit0 and bit1).</p>	0 to 32767 (0.034 1/s)
2208	SV008	VIA	Speed loop advance compensation	<p>Set the speed loop integral gain.</p>	1 to 9999 (0.0687 1/s)

**4.7 Servo Parameters**  
**4.7.1 Servo Parameters**

No.	Item			Details	Setting range (unit)
2209	SV009	IQA	Current loop q-axis advance compensation	Set the current control gain. The data to be set is predetermined for each motor employed. Refer to section "4.7.4 Standard Parameters Setting".	1 to 20480
2210	SV010	IDA	Current loop d-axis advance compensation		1 to 20480
2211	SV011	IQG	Current loop q-axis gain		1 to 2560
2212	SV012	IDG	Current loop d-axis gain		1 to 2560
2213	SV013	ILMT	Current limit value 1	Set the normal current limit value (This is the limit value for both + and – directions.). Set the rate (%) in respect to the stall rated current. For making the maximum driver torque level available, assign "500".	0 to 999 (Stall rated current %)
2214	SV014	ILMTsp	Current limit value 2	Set the rate (%) in respect to the stall rated current for special operations (absolute position initialization, stopper operation, etc). (This is the limit value for both the + and – direction.) For making the maximum driver torque level available, assign "500". Set "0" when this parameter is not used.	0 to 999 (Stall rated current %)
2215	SV015	FFC	Acceleration feed forward gain	Set this parameter when an amount of overshoot caused in feed forward control or a relative error caused in synchronous control is too large. Set "0" when this parameter is not used.	0 to 999 (%)
2216	SV016	LMC1	Lost motion compensation gain 1	Set this parameter if the protrusion (caused by non-sensitive band from friction, torsion, backlash, etc.) is large when the arc quadrant is changed. This is valid only when lost motion compensation SV027 (lmc1, lmc2) is selected.	-1 to 200
				<b>Type 1 SV027 (SSF1) 1mc1=1, 1mc2=0</b> In low-speed interpolation mode, compensation of this type eliminates bump. Setting "0" to this parameter indicates interpolation gain 0. Setting "100" causes 100% compensation.	0 to 200 (%)
				<b>Type 2 SV027 (SSF1) 1mc1=0, 1mc2=1</b> Use type 2 when type 1 is not enough for compensation such as in high-speed, high-accuracy interpolation. Set data in percentage to stall rated current. Set "0" to prevent compensation.	0 to 100 (Stall rated current %)

**4.7 Servo Parameters**  
**4.7.1 Servo Parameters**

No.	Item	Details	Setting range (unit)																																																																																														
		<p>To change the compensation gain (type 1) or compensation amount (type 2) according to the direction.</p> <p>To set a different value according to the command direction, set this with SV041 (LMC2).</p> <p>Set the value for changing the command speed from the – to + direction (during command direction CW) in SV016 (LMC1).</p> <p>Set the value for changing the command speed from the + to – direction (during command direction CW) in SV041 (LMC2).</p> <p>When "-1" is set, compensation will not be carried out when the command speed direction changes.</p>																																																																																															
2217	SV017 SPEC*	<p>Servo specifications</p> <p><b>For MDS-B-V1/V2</b></p> <p>Set the servo system specifications in bit units.</p> <table style="margin-left: 20px; border-collapse: collapse;"> <tr> <td style="text-align: center;">F</td><td style="text-align: center;">E</td><td style="text-align: center;">D</td><td style="text-align: center;">C</td><td style="text-align: center;">B</td><td style="text-align: center;">A</td><td style="text-align: center;">9</td><td style="text-align: center;">8</td> </tr> <tr> <td colspan="6" style="text-align: center;">spm</td> <td style="text-align: center;">mpt3</td> <td style="text-align: center;">mp</td> </tr> </table> <table style="margin-left: 20px; border-collapse: collapse;"> <tr> <td style="text-align: center;">7</td><td style="text-align: center;">6</td><td style="text-align: center;">5</td><td style="text-align: center;">4</td><td style="text-align: center;">3</td><td style="text-align: center;">2</td><td style="text-align: center;">1</td><td style="text-align: center;">0</td> </tr> <tr> <td style="text-align: center;">abs</td><td></td><td style="text-align: center;">vdir</td><td style="text-align: center;">fdir</td><td style="text-align: center;">spwv</td><td style="text-align: center;">seqh</td><td style="text-align: center;">dfbx</td><td style="text-align: center;">vdir2</td> </tr> </table> <p><b>(Note)</b> Always set to a "0" in a blank bit.</p> <table border="1" style="margin-left: 20px; border-collapse: collapse; width: 100%;"> <thead> <tr> <th>bit</th> <th>Name</th> <th>Meaning when set to 0</th> <th>Meaning when set to 1</th> </tr> </thead> <tbody> <tr> <td>0</td> <td>vdir2</td> <td>Speed feedback forward polarity</td> <td>Speed feedback reverse polarity</td> </tr> <tr> <td>1</td> <td>dfbx</td> <td>Dual feedback control invalid</td> <td>Dual feedback control valid</td> </tr> <tr> <td>2</td> <td>seqh</td> <td>Ready/servo ON time normal mode</td> <td>Ready/servo ON time reduced mode</td> </tr> <tr> <td>3</td> <td>spwv</td> <td>Normal mode</td> <td>MDS-B-Vx4/Vx4L Synchronous mode</td> </tr> <tr> <td>4</td> <td>fdir</td> <td>Position feedback forward polarity</td> <td>Position feedback reverse polarity</td> </tr> <tr> <td>5</td> <td>vdir</td> <td>Motor end detector installation direction AC</td> <td>Motor end detector installation direction BD</td> </tr> <tr> <td>6</td> <td></td> <td></td> <td></td> </tr> <tr> <td>7</td> <td>abs</td> <td>Relative position detection</td> <td>Absolute position detection</td> </tr> <tr> <td>8</td> <td>mp</td> <td>MP scale 360P (2mm pitch)</td> <td>MP scale 720P (1mm pitch)</td> </tr> <tr> <td>9</td> <td>mpt3</td> <td>MP scale absolute position detection type 1/2 selection</td> <td>MP scale absolute position detection type 3 selection</td> </tr> <tr> <td>A</td> <td></td> <td></td> <td></td> </tr> <tr> <td>B</td> <td></td> <td></td> <td></td> </tr> <tr> <td>C</td> <td>spm</td> <td colspan="2" rowspan="4">Special motor selection Normally set to "0".</td> </tr> <tr> <td>D</td> <td></td> </tr> <tr> <td>E</td> <td></td> </tr> <tr> <td>F</td> <td></td> </tr> </tbody> </table> <p><b>(Note)</b> [mp] and [mpt3] are valid for the MDS-B-V1 and above servos.</p>	F	E	D	C	B	A	9	8	spm						mpt3	mp	7	6	5	4	3	2	1	0	abs		vdir	fdir	spwv	seqh	dfbx	vdir2	bit	Name	Meaning when set to 0	Meaning when set to 1	0	vdir2	Speed feedback forward polarity	Speed feedback reverse polarity	1	dfbx	Dual feedback control invalid	Dual feedback control valid	2	seqh	Ready/servo ON time normal mode	Ready/servo ON time reduced mode	3	spwv	Normal mode	MDS-B-Vx4/Vx4L Synchronous mode	4	fdir	Position feedback forward polarity	Position feedback reverse polarity	5	vdir	Motor end detector installation direction AC	Motor end detector installation direction BD	6				7	abs	Relative position detection	Absolute position detection	8	mp	MP scale 360P (2mm pitch)	MP scale 720P (1mm pitch)	9	mpt3	MP scale absolute position detection type 1/2 selection	MP scale absolute position detection type 3 selection	A				B				C	spm	Special motor selection Normally set to "0".		D		E		F		0000 to FFFF
F	E	D	C	B	A	9	8																																																																																										
spm						mpt3	mp																																																																																										
7	6	5	4	3	2	1	0																																																																																										
abs		vdir	fdir	spwv	seqh	dfbx	vdir2																																																																																										
bit	Name	Meaning when set to 0	Meaning when set to 1																																																																																														
0	vdir2	Speed feedback forward polarity	Speed feedback reverse polarity																																																																																														
1	dfbx	Dual feedback control invalid	Dual feedback control valid																																																																																														
2	seqh	Ready/servo ON time normal mode	Ready/servo ON time reduced mode																																																																																														
3	spwv	Normal mode	MDS-B-Vx4/Vx4L Synchronous mode																																																																																														
4	fdir	Position feedback forward polarity	Position feedback reverse polarity																																																																																														
5	vdir	Motor end detector installation direction AC	Motor end detector installation direction BD																																																																																														
6																																																																																																	
7	abs	Relative position detection	Absolute position detection																																																																																														
8	mp	MP scale 360P (2mm pitch)	MP scale 720P (1mm pitch)																																																																																														
9	mpt3	MP scale absolute position detection type 1/2 selection	MP scale absolute position detection type 3 selection																																																																																														
A																																																																																																	
B																																																																																																	
C	spm	Special motor selection Normally set to "0".																																																																																															
D																																																																																																	
E																																																																																																	
F																																																																																																	
(Continued on the next page.)																																																																																																	

**4.7 Servo Parameters**  
**4.7.1 Servo Parameters**

No.	Item	Details	Setting range (unit)																																																																																																				
		<p><b>For MDS-B-SVJ2</b> (Continued from the previous page.)</p> <p>Set the servo system specifications in bit units.</p> <table style="width: 100%; text-align: center; border-collapse: collapse;"> <tr> <td style="border: none;">F</td><td style="border: none;">E</td><td style="border: none;">D</td><td style="border: none;">C</td><td style="border: none;">B</td><td style="border: none;">A</td><td style="border: none;">9</td><td style="border: none;">8</td> </tr> <tr> <td style="border: 1px solid black; width: 25px; height: 20px;"></td> <td style="border: 1px solid black; width: 25px; height: 20px;"></td> <td style="border: 1px solid black; width: 25px; height: 20px;"></td> <td style="border: 1px solid black; width: 25px; height: 20px;"></td> <td style="border: 1px solid black; width: 25px; height: 20px;"></td> <td style="border: 1px solid black; width: 25px; height: 20px;"></td> <td style="border: 1px solid black; width: 25px; height: 20px;"></td> <td style="border: 1px solid black; width: 25px; height: 20px;"></td> </tr> </table> <table style="width: 100%; text-align: center; border-collapse: collapse;"> <tr> <td style="border: none;">7</td><td style="border: none;">6</td><td style="border: none;">5</td><td style="border: none;">4</td><td style="border: none;">3</td><td style="border: none;">2</td><td style="border: none;">1</td><td style="border: none;">0</td> </tr> <tr> <td style="border: 1px solid black; width: 25px; height: 20px;">abs</td> <td style="border: 1px solid black; width: 25px; height: 20px;"></td> <td style="border: 1px solid black; width: 25px; height: 20px;">vdir</td> <td style="border: 1px solid black; width: 25px; height: 20px;"></td> <td style="border: 1px solid black; width: 25px; height: 20px;">mc</td> <td style="border: 1px solid black; width: 25px; height: 20px;"></td> <td style="border: 1px solid black; width: 25px; height: 20px;"></td> <td style="border: 1px solid black; width: 25px; height: 20px;">dmk</td> </tr> </table> <table border="1" style="width: 100%; border-collapse: collapse; margin-top: 5px;"> <thead> <tr> <th style="width: 5%;">bit</th> <th style="width: 15%;">Name</th> <th style="width: 35%;">Meaning when set to 0</th> <th style="width: 45%;">Meaning when set to 1</th> </tr> </thead> <tbody> <tr> <td>0</td> <td>dmk</td> <td>Deceleration control stop</td> <td>Dynamic brake stop</td> </tr> <tr> <td>1</td> <td></td> <td></td> <td></td> </tr> <tr> <td>2</td> <td></td> <td></td> <td></td> </tr> <tr> <td>3</td> <td>mc</td> <td>Contactur control output invalid</td> <td>Contactur control output valid</td> </tr> <tr> <td>4</td> <td></td> <td></td> <td></td> </tr> <tr> <td>5</td> <td>vdir</td> <td>HA053N to HA33N motor end detector installation position standard (A, C)</td> <td>HA053N to HA33N motor end detector installation position 90° (B, D)</td> </tr> <tr> <td>6</td> <td></td> <td></td> <td></td> </tr> <tr> <td>7</td> <td>abs</td> <td>Incremental control</td> <td>Absolute position control</td> </tr> <tr> <td>8</td> <td></td> <td></td> <td></td> </tr> <tr> <td>9</td> <td></td> <td></td> <td></td> </tr> <tr> <td>A</td> <td></td> <td></td> <td></td> </tr> <tr> <td>B</td> <td></td> <td></td> <td></td> </tr> <tr> <td>C</td> <td></td> <td></td> <td></td> </tr> <tr> <td>D</td> <td></td> <td></td> <td></td> </tr> <tr> <td>E</td> <td></td> <td></td> <td></td> </tr> <tr> <td>F</td> <td></td> <td></td> <td></td> </tr> </tbody> </table> <p><b>(Note)</b> Set "0" in bits with no particular description.</p> <p>(Continued on the next page.)</p>	F	E	D	C	B	A	9	8									7	6	5	4	3	2	1	0	abs		vdir		mc			dmk	bit	Name	Meaning when set to 0	Meaning when set to 1	0	dmk	Deceleration control stop	Dynamic brake stop	1				2				3	mc	Contactur control output invalid	Contactur control output valid	4				5	vdir	HA053N to HA33N motor end detector installation position standard (A, C)	HA053N to HA33N motor end detector installation position 90° (B, D)	6				7	abs	Incremental control	Absolute position control	8				9				A				B				C				D				E				F				
F	E	D	C	B	A	9	8																																																																																																
7	6	5	4	3	2	1	0																																																																																																
abs		vdir		mc			dmk																																																																																																
bit	Name	Meaning when set to 0	Meaning when set to 1																																																																																																				
0	dmk	Deceleration control stop	Dynamic brake stop																																																																																																				
1																																																																																																							
2																																																																																																							
3	mc	Contactur control output invalid	Contactur control output valid																																																																																																				
4																																																																																																							
5	vdir	HA053N to HA33N motor end detector installation position standard (A, C)	HA053N to HA33N motor end detector installation position 90° (B, D)																																																																																																				
6																																																																																																							
7	abs	Incremental control	Absolute position control																																																																																																				
8																																																																																																							
9																																																																																																							
A																																																																																																							
B																																																																																																							
C																																																																																																							
D																																																																																																							
E																																																																																																							
F																																																																																																							

**4.7 Servo Parameters**  
**4.7.1 Servo Parameters**

No.	Item			Details	Setting range (unit)																																																																																											
				<p><b>For intelligent servo</b> (Continued from the previous page.)</p> <p>Set the servo system specifications in bit units.</p> <table style="width: 100%; text-align: center; border-collapse: collapse;"> <tr> <td style="width: 12.5%;">F</td><td style="width: 12.5%;">E</td><td style="width: 12.5%;">D</td><td style="width: 12.5%;">C</td><td style="width: 12.5%;">B</td><td style="width: 12.5%;">A</td><td style="width: 12.5%;">9</td><td style="width: 12.5%;">8</td> </tr> <tr> <td colspan="8" style="border: 1px solid black; height: 20px;">mtc</td> </tr> <tr> <td style="width: 12.5%;">7</td><td style="width: 12.5%;">6</td><td style="width: 12.5%;">5</td><td style="width: 12.5%;">4</td><td style="width: 12.5%;">3</td><td style="width: 12.5%;">2</td><td style="width: 12.5%;">1</td><td style="width: 12.5%;">0</td> </tr> <tr> <td style="border: 1px solid black;">abs</td><td style="border: 1px solid black;"></td><td style="border: 1px solid black;"></td><td style="border: 1px solid black;"></td><td style="border: 1px solid black;"></td><td style="border: 1px solid black;"></td><td style="border: 1px solid black;"></td><td style="border: 1px solid black;">dmk</td> </tr> </table> <table border="1" style="width: 100%; border-collapse: collapse; margin-top: 5px;"> <thead> <tr> <th style="width: 5%;">bit</th> <th style="width: 15%;">Name</th> <th style="width: 40%;">Meaning when set to 0</th> <th style="width: 40%;">Meaning when set to 1</th> </tr> </thead> <tbody> <tr> <td style="text-align: center;">0</td> <td>dmk</td> <td>Deceleration control stop (SVJ2 standard)</td> <td>Dynamic brake stop</td> </tr> <tr><td style="text-align: center;">1</td><td></td><td></td><td></td></tr> <tr><td style="text-align: center;">2</td><td></td><td></td><td></td></tr> <tr><td style="text-align: center;">3</td><td></td><td></td><td></td></tr> <tr><td style="text-align: center;">4</td><td></td><td></td><td></td></tr> <tr><td style="text-align: center;">5</td><td></td><td></td><td></td></tr> <tr><td style="text-align: center;">6</td><td></td><td></td><td></td></tr> <tr> <td style="text-align: center;">7</td> <td>abs</td> <td>Incremental control</td> <td>Absolute position control</td> </tr> <tr><td style="text-align: center;">8</td><td></td><td></td><td></td></tr> <tr><td style="text-align: center;">9</td><td></td><td></td><td></td></tr> <tr><td style="text-align: center;">A</td><td></td><td></td><td></td></tr> <tr><td style="text-align: center;">B</td><td></td><td></td><td></td></tr> <tr> <td style="text-align: center;">C</td> <td rowspan="4" style="vertical-align: top;">mtc</td> <td colspan="2" rowspan="4">Selecting the motor table for each model Set 0100 for the intelligent servomotor HS Series.</td> </tr> <tr><td style="text-align: center;">D</td></tr> <tr><td style="text-align: center;">E</td></tr> <tr><td style="text-align: center;">F</td></tr> </tbody> </table> <p><b>(Note)</b> Set "0" in bits with no particular description.</p>	F	E	D	C	B	A	9	8	mtc								7	6	5	4	3	2	1	0	abs							dmk	bit	Name	Meaning when set to 0	Meaning when set to 1	0	dmk	Deceleration control stop (SVJ2 standard)	Dynamic brake stop	1				2				3				4				5				6				7	abs	Incremental control	Absolute position control	8				9				A				B				C	mtc	Selecting the motor table for each model Set 0100 for the intelligent servomotor HS Series.		D	E	F	
F	E	D	C	B	A	9	8																																																																																									
mtc																																																																																																
7	6	5	4	3	2	1	0																																																																																									
abs							dmk																																																																																									
bit	Name	Meaning when set to 0	Meaning when set to 1																																																																																													
0	dmk	Deceleration control stop (SVJ2 standard)	Dynamic brake stop																																																																																													
1																																																																																																
2																																																																																																
3																																																																																																
4																																																																																																
5																																																																																																
6																																																																																																
7	abs	Incremental control	Absolute position control																																																																																													
8																																																																																																
9																																																																																																
A																																																																																																
B																																																																																																
C	mtc	Selecting the motor table for each model Set 0100 for the intelligent servomotor HS Series.																																																																																														
D																																																																																																
E																																																																																																
F																																																																																																
2218	SV018	PIT*	Ball screw pitch	<p>Set the ball screw pitch.  Set "360" for a rotation axis.  Refer to section "4.7.2 Supplementary Explanation".  Always set "360" when using the spindle-type servomotor control spindle/C axis.</p>	1 to 32767 (mm)																																																																																											

**4.7 Servo Parameters**  
**4.7.1 Servo Parameters**

No.	Item		Details	Setting range (unit)																																																		
2219	SV019	RNG1*	Position detector resolution  Set the number of pulses per rotation of the detector used for position control.  <table border="1" style="width: 100%; border-collapse: collapse;"> <thead> <tr> <th style="text-align: center;">Motor capacity</th> <th style="text-align: center;">pulse/rev</th> <th style="text-align: center;">Position/Speed detector</th> <th style="text-align: center;">RNG1</th> <th style="text-align: center;">RNG2</th> </tr> </thead> <tbody> <tr> <td style="text-align: center;">50/100W</td> <td style="text-align: center;">2500</td> <td>Detector built in the HA053/HA13 motor</td> <td style="text-align: center;">10</td> <td style="text-align: center;">10</td> </tr> <tr> <td style="text-align: center;">200W or more</td> <td style="text-align: center;">25000</td> <td>OHE25K-6/OSE104 OHE25K-85/OSE104S OHA25K-4/OA104 OHA25K-85/OA104S</td> <td style="text-align: center;">100</td> <td style="text-align: center;">100</td> </tr> <tr> <td style="text-align: center;">200W or more</td> <td style="text-align: center;">25000</td> <td>OHE25K-ET/OSE104ET OHA25K-ET/OA104ET</td> <td style="text-align: center;">100</td> <td style="text-align: center;">X</td> </tr> <tr> <td style="text-align: center;">200W or more</td> <td style="text-align: center;">1,000,000</td> <td>OHE105/OSE105S OHA105/OA105S</td> <td style="text-align: center;">1000</td> <td style="text-align: center;">1000</td> </tr> <tr> <td colspan="3">Linear scale</td> <td style="text-align: center;">PIT</td> <td></td> </tr> <tr> <td colspan="3">Inductosyn</td> <td style="text-align: center;">Scale resolution</td> <td style="text-align: center;">X</td> </tr> <tr> <td style="text-align: center;">General-purpose servo-motor</td> <td style="text-align: center;">8000</td> <td>HC-MF motor</td> <td style="text-align: center;">8</td> <td style="text-align: center;">8</td> </tr> <tr> <td style="text-align: center;">Intelligent servo-motor</td> <td style="text-align: center;">100000</td> <td>HS-RF</td> <td style="text-align: center;">100</td> <td style="text-align: center;">100</td> </tr> <tr> <td></td> <td></td> <td>HS-SF</td> <td style="text-align: center;">100</td> <td style="text-align: center;">100</td> </tr> </tbody> </table> <p>X : Set the parameter corresponding to each motor end detector type. (10, 100, 1000)</p> <p><b>&lt;Semi-closed loop&gt;</b> Set the number of pulses per rotation of the motor. (RNG1=RNG2) <b>(Note)</b> When using the MDS-B-SVJ2, this is valid only for the semi-closed loop.</p> <p><b>&lt;Closed loop&gt;</b> Set the number of pulses per ball screw pitch. When using an MP scale, set the value obtained from the following calculation expression:  <math display="block">\text{Setting value} = \frac{\text{Ball screw pitch (mm)}}{\text{MP scale resolution } (\mu)}</math>           (Note that, MP scale resolution = <math>\frac{2\text{mm}}{\text{No. of grid spaces}}</math> )</p>	Motor capacity	pulse/rev	Position/Speed detector	RNG1	RNG2	50/100W	2500	Detector built in the HA053/HA13 motor	10	10	200W or more	25000	OHE25K-6/OSE104 OHE25K-85/OSE104S OHA25K-4/OA104 OHA25K-85/OA104S	100	100	200W or more	25000	OHE25K-ET/OSE104ET OHA25K-ET/OA104ET	100	X	200W or more	1,000,000	OHE105/OSE105S OHA105/OA105S	1000	1000	Linear scale			PIT		Inductosyn			Scale resolution	X	General-purpose servo-motor	8000	HC-MF motor	8	8	Intelligent servo-motor	100000	HS-RF	100	100			HS-SF	100	100	Semi-closed loop: 8 to 1000 (pulse/rev) For MDS-B-SVJ2: 8 to 100 (pulse/rev)  Closed loop: 8 to 1000 (pulse/pitch)
Motor capacity	pulse/rev	Position/Speed detector	RNG1	RNG2																																																		
50/100W	2500	Detector built in the HA053/HA13 motor	10	10																																																		
200W or more	25000	OHE25K-6/OSE104 OHE25K-85/OSE104S OHA25K-4/OA104 OHA25K-85/OA104S	100	100																																																		
200W or more	25000	OHE25K-ET/OSE104ET OHA25K-ET/OA104ET	100	X																																																		
200W or more	1,000,000	OHE105/OSE105S OHA105/OA105S	1000	1000																																																		
Linear scale			PIT																																																			
Inductosyn			Scale resolution	X																																																		
General-purpose servo-motor	8000	HC-MF motor	8	8																																																		
Intelligent servo-motor	100000	HS-RF	100	100																																																		
		HS-SF	100	100																																																		
2220	SV020	RNG2*	Speed detector resolution  Set the number of pulses per rotation of the motor end detector. (Refer to RNG1 setting.)	1 to 9999 (pulse/rev)																																																		
2221	SV021	OLT	Overload time constant  Set the time constant for detection of overload 1 (OL1) Set "60" for ordinary operation. When using a 15kW driver (HA-A15KL), the upper limit value is 3 (s).	1 to 300 (s)																																																		
2222	SV022	OLL	Overload detection level  Set the current detection level of overload 1 (OL1) with respect to the stall rated current (%). Set "150" for ordinary operation.	1 to 500 (Stall rated current %) For MDS-B-SVJ2: 50 to 180 (Stall rated current %)																																																		

**4.7 Servo Parameters**  
**4.7.1 Servo Parameters**

---

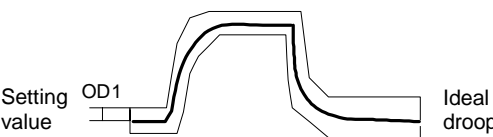
No.	Item		Details	Setting range (unit)
2223	SV023	OD1	Excessive detection error width 1 Set the excessive detection error width at the time of servo-ON. <Setting equation> $OD1 = OD2 = OD3 = \frac{F}{60 \times PGN1} \times 0.5 \text{ (mm)}$  <p style="margin-left: 40px;">F : Max. rapid traverse rate (mm/min)            PGN1 : Position loop gain 1 (1/s)</p> When "0" is set, the excessive error at servo ON will not be detected.	0 to 32767 (mm)
2224	SV024	INP	In-position width Set the in-position width value. (μm) Set "50" for ordinary operation.	0 to 32767 (μm)

**4.7 Servo Parameters**  
**4.7.1 Servo Parameters**

No.	Item	Details	Setting range (unit)																																																																																																																																																																																																																																																																																																																																																																					
2225	SV025: MTYP*	Motor type	0000 to FFFF HEX setting																																																																																																																																																																																																																																																																																																																																																																					
		Set the motor and detector types. <div style="text-align: center; border: 1px solid black; padding: 5px;">             F E D C B A 9 8 7 6 5 4 3 2 1 0              pen            ent            mtyp           </div> [mtyp] Motor type (For MDS-B-V1/V2) (Select one from the tables below.)																																																																																																																																																																																																																																																																																																																																																																						
		<table border="1" style="width: 100%; border-collapse: collapse; text-align: center;"> <thead> <tr> <th rowspan="2">Motor series</th> <th colspan="2">2000r/min standard</th> <th colspan="2">2000r/min low inertia</th> <th colspan="2">3000r/min low inertia</th> <th></th> <th></th> <th></th> </tr> <tr> <th>No.</th> <th>0x</th> <th>1x</th> <th>2x</th> <th>3x</th> <th>4x</th> <th>5x</th> <th>6x</th> <th>7x</th> </tr> </thead> <tbody> <tr><td>x0</td><td>HA40N</td><td></td><td></td><td>HA50L</td><td>HA53L</td><td></td><td></td><td></td><td></td></tr> <tr><td>x1</td><td>HA80N</td><td></td><td></td><td>HA100L</td><td>HA103L</td><td></td><td></td><td></td><td></td></tr> <tr><td>x2</td><td>HA100N</td><td></td><td></td><td>HA200L</td><td>HA203L</td><td></td><td></td><td></td><td></td></tr> <tr><td>x3</td><td>HA200N</td><td></td><td></td><td>HA300L</td><td>HA303L</td><td></td><td></td><td></td><td></td></tr> <tr><td>x4</td><td>HA300N</td><td></td><td></td><td>HA500L</td><td>HA503L</td><td></td><td></td><td></td><td></td></tr> <tr><td>x5</td><td>HA700N</td><td></td><td></td><td></td><td></td><td></td><td></td><td></td><td></td></tr> <tr><td>x6</td><td>HA900N</td><td></td><td></td><td></td><td></td><td></td><td></td><td></td><td></td></tr> <tr><td>x7</td><td></td><td></td><td></td><td>HA-A11KL</td><td></td><td></td><td></td><td></td><td></td></tr> <tr><td>x8</td><td></td><td></td><td></td><td>HA-A15KL</td><td></td><td></td><td></td><td></td><td></td></tr> <tr><td>x9</td><td></td><td></td><td></td><td></td><td></td><td></td><td></td><td></td><td></td></tr> <tr><td>xA</td><td></td><td></td><td></td><td>HA150L</td><td>HA153L</td><td></td><td></td><td></td><td></td></tr> <tr><td>xB</td><td></td><td></td><td></td><td></td><td></td><td></td><td></td><td></td><td></td></tr> <tr><td>xC</td><td></td><td></td><td></td><td></td><td></td><td></td><td></td><td></td><td></td></tr> <tr><td>xD</td><td></td><td></td><td></td><td></td><td></td><td></td><td></td><td></td><td></td></tr> <tr><td>xE</td><td></td><td></td><td></td><td></td><td></td><td></td><td></td><td></td><td></td></tr> <tr><td>xF</td><td></td><td></td><td></td><td></td><td></td><td></td><td></td><td></td><td></td></tr> </tbody> </table> <table border="1" style="width: 100%; border-collapse: collapse; text-align: center;"> <thead> <tr> <th rowspan="2">Motor series</th> <th colspan="3">3000r/min standard</th> <th>HC2000 r/min standard</th> <th>HC3000 r/min standard</th> <th></th> <th colspan="2">HC3000 r/min low inertia</th> </tr> <tr> <th>No.</th> <th>8x</th> <th>9x</th> <th>Ax</th> <th>Bx</th> <th>Cx</th> <th>Dx</th> <th>Ex</th> <th>Fx</th> </tr> </thead> <tbody> <tr><td>x0</td><td>HA43N</td><td></td><td></td><td></td><td>HC52</td><td>HC53</td><td></td><td></td><td></td></tr> <tr><td>x1</td><td>HA83N</td><td></td><td></td><td></td><td>HC102</td><td>HC103</td><td></td><td>HC103R</td><td></td></tr> <tr><td>x2</td><td>H103N</td><td></td><td></td><td></td><td>HC152</td><td>HC153</td><td></td><td>HC153R</td><td></td></tr> <tr><td>x3</td><td>HA203N</td><td></td><td></td><td></td><td>HC202</td><td>HC203</td><td></td><td>HC203R</td><td></td></tr> <tr><td>x4</td><td>HA303N</td><td></td><td></td><td></td><td>HC352</td><td>HC353</td><td></td><td>HC353R</td><td></td></tr> <tr><td>x5</td><td>HA703N</td><td></td><td></td><td></td><td>HC452</td><td>HC453</td><td></td><td>HC503R</td><td></td></tr> <tr><td>x6</td><td></td><td></td><td></td><td></td><td>HC702</td><td>HC703</td><td></td><td></td><td></td></tr> <tr><td>x7</td><td></td><td></td><td></td><td></td><td>HC902</td><td></td><td></td><td></td><td></td></tr> <tr><td>x8</td><td></td><td></td><td></td><td></td><td></td><td></td><td></td><td></td><td></td></tr> <tr><td>x9</td><td></td><td></td><td></td><td></td><td></td><td></td><td></td><td></td><td></td></tr> <tr><td>xA</td><td>HA93N</td><td></td><td></td><td></td><td></td><td></td><td></td><td></td><td></td></tr> <tr><td>xB</td><td></td><td></td><td></td><td></td><td></td><td></td><td></td><td></td><td></td></tr> <tr><td>xC</td><td>HA053</td><td></td><td></td><td></td><td></td><td></td><td></td><td></td><td></td></tr> <tr><td>xD</td><td>HA13</td><td></td><td></td><td></td><td></td><td></td><td></td><td></td><td></td></tr> <tr><td>xE</td><td>HA23N</td><td></td><td></td><td></td><td></td><td></td><td></td><td></td><td></td></tr> <tr><td>xF</td><td>HA33N</td><td></td><td></td><td></td><td></td><td></td><td></td><td></td><td></td></tr> </tbody> </table>	Motor series	2000r/min standard		2000r/min low inertia		3000r/min low inertia					No.	0x	1x	2x	3x	4x	5x	6x	7x	x0	HA40N			HA50L	HA53L					x1	HA80N			HA100L	HA103L					x2	HA100N			HA200L	HA203L					x3	HA200N			HA300L	HA303L					x4	HA300N			HA500L	HA503L					x5	HA700N									x6	HA900N									x7				HA-A11KL						x8				HA-A15KL						x9										xA				HA150L	HA153L					xB										xC										xD										xE										xF										Motor series	3000r/min standard			HC2000 r/min standard	HC3000 r/min standard		HC3000 r/min low inertia		No.	8x	9x	Ax	Bx	Cx	Dx	Ex	Fx	x0	HA43N				HC52	HC53				x1	HA83N				HC102	HC103		HC103R		x2	H103N				HC152	HC153		HC153R		x3	HA203N				HC202	HC203		HC203R		x4	HA303N				HC352	HC353		HC353R		x5	HA703N				HC452	HC453		HC503R		x6					HC702	HC703				x7					HC902					x8										x9										xA	HA93N									xB										xC	HA053									xD	HA13									xE	HA23N									xF	HA33N									
Motor series	2000r/min standard			2000r/min low inertia		3000r/min low inertia																																																																																																																																																																																																																																																																																																																																																																		
	No.	0x	1x	2x	3x	4x	5x	6x	7x																																																																																																																																																																																																																																																																																																																																																															
x0	HA40N			HA50L	HA53L																																																																																																																																																																																																																																																																																																																																																																			
x1	HA80N			HA100L	HA103L																																																																																																																																																																																																																																																																																																																																																																			
x2	HA100N			HA200L	HA203L																																																																																																																																																																																																																																																																																																																																																																			
x3	HA200N			HA300L	HA303L																																																																																																																																																																																																																																																																																																																																																																			
x4	HA300N			HA500L	HA503L																																																																																																																																																																																																																																																																																																																																																																			
x5	HA700N																																																																																																																																																																																																																																																																																																																																																																							
x6	HA900N																																																																																																																																																																																																																																																																																																																																																																							
x7				HA-A11KL																																																																																																																																																																																																																																																																																																																																																																				
x8				HA-A15KL																																																																																																																																																																																																																																																																																																																																																																				
x9																																																																																																																																																																																																																																																																																																																																																																								
xA				HA150L	HA153L																																																																																																																																																																																																																																																																																																																																																																			
xB																																																																																																																																																																																																																																																																																																																																																																								
xC																																																																																																																																																																																																																																																																																																																																																																								
xD																																																																																																																																																																																																																																																																																																																																																																								
xE																																																																																																																																																																																																																																																																																																																																																																								
xF																																																																																																																																																																																																																																																																																																																																																																								
Motor series	3000r/min standard			HC2000 r/min standard	HC3000 r/min standard		HC3000 r/min low inertia																																																																																																																																																																																																																																																																																																																																																																	
	No.	8x	9x	Ax	Bx	Cx	Dx	Ex	Fx																																																																																																																																																																																																																																																																																																																																																															
x0	HA43N				HC52	HC53																																																																																																																																																																																																																																																																																																																																																																		
x1	HA83N				HC102	HC103		HC103R																																																																																																																																																																																																																																																																																																																																																																
x2	H103N				HC152	HC153		HC153R																																																																																																																																																																																																																																																																																																																																																																
x3	HA203N				HC202	HC203		HC203R																																																																																																																																																																																																																																																																																																																																																																
x4	HA303N				HC352	HC353		HC353R																																																																																																																																																																																																																																																																																																																																																																
x5	HA703N				HC452	HC453		HC503R																																																																																																																																																																																																																																																																																																																																																																
x6					HC702	HC703																																																																																																																																																																																																																																																																																																																																																																		
x7					HC902																																																																																																																																																																																																																																																																																																																																																																			
x8																																																																																																																																																																																																																																																																																																																																																																								
x9																																																																																																																																																																																																																																																																																																																																																																								
xA	HA93N																																																																																																																																																																																																																																																																																																																																																																							
xB																																																																																																																																																																																																																																																																																																																																																																								
xC	HA053																																																																																																																																																																																																																																																																																																																																																																							
xD	HA13																																																																																																																																																																																																																																																																																																																																																																							
xE	HA23N																																																																																																																																																																																																																																																																																																																																																																							
xF	HA33N																																																																																																																																																																																																																																																																																																																																																																							
		(Continued on the next page.)																																																																																																																																																																																																																																																																																																																																																																						



**4.7 Servo Parameters**  
**4.7.1 Servo Parameters**

No.	Item	Details	Setting range (unit)																																																																																																																																																																																																																																																																																																																																				
		(Continued from the previous page.) [mtyp] Motor type (For MDS-B-SVJ2) (Select one from the tables below.)																																																																																																																																																																																																																																																																																																																																					
		<table border="1" style="width: 100%; border-collapse: collapse;"> <thead> <tr> <th>Motor series</th> <th colspan="7">2000r/min standard</th> <th>3000r/min low inertia</th> </tr> <tr> <th>No.</th> <th>0x</th> <th>1x</th> <th>2x</th> <th>3x</th> <th>4x</th> <th>5x</th> <th>6x</th> <th>7x</th> </tr> </thead> <tbody> <tr><td>x0</td><td>HA40N</td><td></td><td></td><td></td><td></td><td></td><td></td><td>HA-FF43</td></tr> <tr><td>x1</td><td>HA80N</td><td></td><td></td><td></td><td></td><td></td><td></td><td>HA-FF63</td></tr> <tr><td>x2</td><td>HA100N</td><td></td><td></td><td></td><td></td><td></td><td></td><td></td></tr> <tr><td>x3</td><td></td><td></td><td></td><td></td><td></td><td></td><td></td><td></td></tr> <tr><td>x4</td><td></td><td></td><td></td><td></td><td></td><td></td><td></td><td></td></tr> <tr><td>x5</td><td></td><td></td><td></td><td></td><td></td><td></td><td></td><td></td></tr> <tr><td>x6</td><td></td><td></td><td></td><td></td><td></td><td></td><td></td><td></td></tr> <tr><td>x7</td><td></td><td></td><td></td><td></td><td></td><td></td><td></td><td></td></tr> <tr><td>x8</td><td></td><td></td><td></td><td></td><td></td><td></td><td></td><td></td></tr> <tr><td>x9</td><td></td><td></td><td></td><td></td><td></td><td></td><td></td><td></td></tr> <tr><td>xA</td><td></td><td></td><td></td><td></td><td></td><td></td><td></td><td></td></tr> <tr><td>xB</td><td></td><td></td><td></td><td></td><td></td><td></td><td></td><td></td></tr> <tr><td>xC</td><td></td><td></td><td></td><td></td><td></td><td></td><td></td><td>HA-FF053</td></tr> <tr><td>xD</td><td></td><td></td><td></td><td></td><td></td><td></td><td></td><td>HA-FF13</td></tr> <tr><td>xE</td><td></td><td></td><td></td><td></td><td></td><td></td><td></td><td>HA-FF23</td></tr> <tr><td>xF</td><td></td><td></td><td></td><td></td><td></td><td></td><td></td><td>HA-FF33</td></tr> </tbody> </table> <table border="1" style="width: 100%; border-collapse: collapse;"> <thead> <tr> <th>Motor series</th> <th>3000r/min standard</th> <th colspan="2">HC3000 r/min general-purpose ultra low inertia</th> <th>HC2000 r/min standard</th> <th>HC3000 r/min standard</th> <th></th> <th colspan="2">HC3000 r/min low inertia</th> </tr> <tr> <th>No.</th> <th>8x</th> <th>9x</th> <th>Ax</th> <th>Bx</th> <th>Cx</th> <th>Dx</th> <th>Ex</th> <th>Fx</th> </tr> </thead> <tbody> <tr> <td>x0</td> <td>HA43N</td> <td>HC-MF43</td> <td></td> <td>HC52 or HC-SF52</td> <td>HC53 or HC-SF53</td> <td></td> <td></td> <td></td> </tr> <tr> <td>x1</td> <td>HA83N</td> <td>HC-MF73</td> <td></td> <td>HC102 or HC-SF102</td> <td>HC103 or HC-SF103</td> <td></td> <td colspan="2">HC103R or HC-RF103</td> </tr> <tr> <td>x2</td> <td></td> <td></td> <td></td> <td>HC152 or HC-SF152</td> <td>HC153 or HC-SF153</td> <td></td> <td colspan="2">HC153R or HC-RF153</td> </tr> <tr> <td>x3</td> <td></td> <td></td> <td></td> <td>HC202 or HC-SF202</td> <td>HC203 or HC-SF203</td> <td></td> <td colspan="2">HC203R or HC-RF203</td> </tr> <tr> <td>x4</td> <td></td> <td></td> <td></td> <td>HC-SF352</td> <td>HC-SF353</td> <td></td> <td></td> <td></td> </tr> <tr><td>x5</td><td></td><td></td><td></td><td></td><td></td><td></td><td></td><td></td></tr> <tr><td>x6</td><td></td><td></td><td></td><td></td><td></td><td></td><td></td><td></td></tr> <tr><td>x7</td><td></td><td></td><td></td><td></td><td></td><td></td><td></td><td></td></tr> <tr><td>x8</td><td></td><td></td><td></td><td></td><td></td><td></td><td></td><td></td></tr> <tr><td>x9</td><td></td><td></td><td></td><td></td><td></td><td></td><td></td><td></td></tr> <tr><td>xA</td><td>HA93N</td><td></td><td></td><td></td><td></td><td></td><td></td><td></td></tr> <tr><td>xB</td><td></td><td></td><td></td><td></td><td></td><td></td><td></td><td></td></tr> <tr><td>xC</td><td>HA053N</td><td>HC-MF053</td><td></td><td></td><td></td><td></td><td></td><td></td></tr> <tr><td>xD</td><td>HA13N</td><td>HC-MF13</td><td></td><td></td><td></td><td></td><td></td><td></td></tr> <tr><td>xE</td><td>HA23N</td><td>HC-MF23</td><td></td><td></td><td></td><td></td><td></td><td></td></tr> <tr><td>xF</td><td>HA33N</td><td></td><td></td><td></td><td></td><td></td><td></td><td></td></tr> </tbody> </table>	Motor series	2000r/min standard							3000r/min low inertia	No.	0x	1x	2x	3x	4x	5x	6x	7x	x0	HA40N							HA-FF43	x1	HA80N							HA-FF63	x2	HA100N								x3									x4									x5									x6									x7									x8									x9									xA									xB									xC								HA-FF053	xD								HA-FF13	xE								HA-FF23	xF								HA-FF33	Motor series	3000r/min standard	HC3000 r/min general-purpose ultra low inertia		HC2000 r/min standard	HC3000 r/min standard		HC3000 r/min low inertia		No.	8x	9x	Ax	Bx	Cx	Dx	Ex	Fx	x0	HA43N	HC-MF43		HC52 or HC-SF52	HC53 or HC-SF53				x1	HA83N	HC-MF73		HC102 or HC-SF102	HC103 or HC-SF103		HC103R or HC-RF103		x2				HC152 or HC-SF152	HC153 or HC-SF153		HC153R or HC-RF153		x3				HC202 or HC-SF202	HC203 or HC-SF203		HC203R or HC-RF203		x4				HC-SF352	HC-SF353				x5									x6									x7									x8									x9									xA	HA93N								xB									xC	HA053N	HC-MF053							xD	HA13N	HC-MF13							xE	HA23N	HC-MF23							xF	HA33N								
Motor series	2000r/min standard							3000r/min low inertia																																																																																																																																																																																																																																																																																																																															
No.	0x	1x	2x	3x	4x	5x	6x	7x																																																																																																																																																																																																																																																																																																																															
x0	HA40N							HA-FF43																																																																																																																																																																																																																																																																																																																															
x1	HA80N							HA-FF63																																																																																																																																																																																																																																																																																																																															
x2	HA100N																																																																																																																																																																																																																																																																																																																																						
x3																																																																																																																																																																																																																																																																																																																																							
x4																																																																																																																																																																																																																																																																																																																																							
x5																																																																																																																																																																																																																																																																																																																																							
x6																																																																																																																																																																																																																																																																																																																																							
x7																																																																																																																																																																																																																																																																																																																																							
x8																																																																																																																																																																																																																																																																																																																																							
x9																																																																																																																																																																																																																																																																																																																																							
xA																																																																																																																																																																																																																																																																																																																																							
xB																																																																																																																																																																																																																																																																																																																																							
xC								HA-FF053																																																																																																																																																																																																																																																																																																																															
xD								HA-FF13																																																																																																																																																																																																																																																																																																																															
xE								HA-FF23																																																																																																																																																																																																																																																																																																																															
xF								HA-FF33																																																																																																																																																																																																																																																																																																																															
Motor series	3000r/min standard	HC3000 r/min general-purpose ultra low inertia		HC2000 r/min standard	HC3000 r/min standard		HC3000 r/min low inertia																																																																																																																																																																																																																																																																																																																																
No.	8x	9x	Ax	Bx	Cx	Dx	Ex	Fx																																																																																																																																																																																																																																																																																																																															
x0	HA43N	HC-MF43		HC52 or HC-SF52	HC53 or HC-SF53																																																																																																																																																																																																																																																																																																																																		
x1	HA83N	HC-MF73		HC102 or HC-SF102	HC103 or HC-SF103		HC103R or HC-RF103																																																																																																																																																																																																																																																																																																																																
x2				HC152 or HC-SF152	HC153 or HC-SF153		HC153R or HC-RF153																																																																																																																																																																																																																																																																																																																																
x3				HC202 or HC-SF202	HC203 or HC-SF203		HC203R or HC-RF203																																																																																																																																																																																																																																																																																																																																
x4				HC-SF352	HC-SF353																																																																																																																																																																																																																																																																																																																																		
x5																																																																																																																																																																																																																																																																																																																																							
x6																																																																																																																																																																																																																																																																																																																																							
x7																																																																																																																																																																																																																																																																																																																																							
x8																																																																																																																																																																																																																																																																																																																																							
x9																																																																																																																																																																																																																																																																																																																																							
xA	HA93N																																																																																																																																																																																																																																																																																																																																						
xB																																																																																																																																																																																																																																																																																																																																							
xC	HA053N	HC-MF053																																																																																																																																																																																																																																																																																																																																					
xD	HA13N	HC-MF13																																																																																																																																																																																																																																																																																																																																					
xE	HA23N	HC-MF23																																																																																																																																																																																																																																																																																																																																					
xF	HA33N																																																																																																																																																																																																																																																																																																																																						
		(Continued on the next page.)																																																																																																																																																																																																																																																																																																																																					

**4.7 Servo Parameters**  
**4.7.1 Servo Parameters**

No.	Item		Details	Setting range (unit)																																																																						
			(Continued from the previous page.) [ent] Speed detector type Select the type of the detector used from the table below. [pen] Position detector type Select the type of the detector used from the table below.																																																																							
			<table border="1" style="width: 100%; border-collapse: collapse;"> <thead> <tr> <th style="width: 5%;">No.</th> <th style="width: 20%;">Detection method</th> <th style="width: 20%;">Detector type</th> <th style="width: 15%;">Device</th> <th style="width: 40%;">Remarks</th> </tr> </thead> <tbody> <tr> <td rowspan="2">0</td> <td>ABZ+UVW</td> <td>OHE25K</td> <td rowspan="10">Motor end detector</td> <td rowspan="10"></td> </tr> <tr> <td>High-speed serial</td> <td>OSE104</td> </tr> <tr> <td rowspan="2">1</td> <td>ABZ+low speed serial</td> <td>OHA25K</td> </tr> <tr> <td>High-speed serial</td> <td>OSA104</td> </tr> <tr> <td rowspan="2">2</td> <td rowspan="2">High-speed serial</td> <td>OSE105/OSA105/ HA-FH</td> </tr> <tr> <td>OBA13/OSA14/ OBA17</td> </tr> <tr> <td>3</td> <td>ABZ+UVW (No OHM)</td> <td>HA053/HA13/ HA-FE</td> </tr> <tr> <td rowspan="2">4</td> <td>ABZ</td> <td>OHE25K-ET</td> <td rowspan="6">Ball screw end detector</td> <td rowspan="6">Cannot be set to speed detector type (ent)</td> </tr> <tr> <td>High-speed serial</td> <td>OSE104-ET</td> </tr> <tr> <td rowspan="2">5</td> <td>ABZ+low speed serial</td> <td>OHA25K-ET</td> </tr> <tr> <td>High-speed serial</td> <td>OSA104-ET</td> </tr> <tr> <td>6</td> <td>High-speed serial</td> <td>OSE105-ET/ OSA105-ET</td> </tr> <tr> <td>7</td> <td></td> <td></td> </tr> <tr> <td>8</td> <td>ABZ</td> <td>SCALE</td> <td rowspan="4">Machine end detector</td> <td rowspan="4"></td> </tr> <tr> <td>9</td> <td>ABZ+low speed serial</td> <td>ABS SCALE <b>Note 1</b></td> </tr> <tr> <td>A</td> <td>High-speed serial</td> <td>ABS SCALE <b>Note 2</b></td> </tr> <tr> <td>B</td> <td></td> <td></td> </tr> <tr> <td>C</td> <td>High-speed serial</td> <td>OSE104/OSE105/ OSA104/OSA105</td> <td rowspan="4">Synchronous control</td> <td rowspan="4"></td> </tr> <tr> <td>D</td> <td></td> <td></td> </tr> <tr> <td>E</td> <td></td> <td></td> </tr> <tr> <td>F</td> <td></td> <td></td> </tr> </tbody> </table> <p><b>(Note 1)</b> ABS SCALE corresponds to the following absolute position detection scales.            Mitutoyo Corporation AT41            FUTABA Corporation FME type, FLE type</p> <p><b>(Note 2)</b> ABS SCALE corresponds to the following absolute position detection scale.            Mitutoyo Corporation AT342</p>	No.	Detection method	Detector type	Device	Remarks	0	ABZ+UVW	OHE25K	Motor end detector		High-speed serial	OSE104	1	ABZ+low speed serial	OHA25K	High-speed serial	OSA104	2	High-speed serial	OSE105/OSA105/ HA-FH	OBA13/OSA14/ OBA17	3	ABZ+UVW (No OHM)	HA053/HA13/ HA-FE	4	ABZ	OHE25K-ET	Ball screw end detector	Cannot be set to speed detector type (ent)	High-speed serial	OSE104-ET	5	ABZ+low speed serial	OHA25K-ET	High-speed serial	OSA104-ET	6	High-speed serial	OSE105-ET/ OSA105-ET	7			8	ABZ	SCALE	Machine end detector		9	ABZ+low speed serial	ABS SCALE <b>Note 1</b>	A	High-speed serial	ABS SCALE <b>Note 2</b>	B			C	High-speed serial	OSE104/OSE105/ OSA104/OSA105	Synchronous control		D			E			F			
No.	Detection method	Detector type	Device	Remarks																																																																						
0	ABZ+UVW	OHE25K	Motor end detector																																																																							
	High-speed serial	OSE104																																																																								
1	ABZ+low speed serial	OHA25K																																																																								
	High-speed serial	OSA104																																																																								
2	High-speed serial	OSE105/OSA105/ HA-FH																																																																								
		OBA13/OSA14/ OBA17																																																																								
3	ABZ+UVW (No OHM)	HA053/HA13/ HA-FE																																																																								
4	ABZ	OHE25K-ET			Ball screw end detector	Cannot be set to speed detector type (ent)																																																																				
	High-speed serial	OSE104-ET																																																																								
5	ABZ+low speed serial	OHA25K-ET																																																																								
	High-speed serial	OSA104-ET																																																																								
6	High-speed serial	OSE105-ET/ OSA105-ET																																																																								
7																																																																										
8	ABZ	SCALE	Machine end detector																																																																							
9	ABZ+low speed serial	ABS SCALE <b>Note 1</b>																																																																								
A	High-speed serial	ABS SCALE <b>Note 2</b>																																																																								
B																																																																										
C	High-speed serial	OSE104/OSE105/ OSA104/OSA105	Synchronous control																																																																							
D																																																																										
E																																																																										
F																																																																										
2226	SV026	OD2	Excessive detection error width 2	Set the excessive detection error width at the time of servo OFF. (Normally same data as for OD1) When "0" is set, the excessive error at servo OFF will not be detected.	0 to 32767 (mm)																																																																					

**4.7 Servo Parameters**  
**4.7.1 Servo Parameters**

No.	Item	Details	Setting range (unit)																																																																
2227	SV027	SSF1 Special servo function 1	0000 to FFFF HEX setting																																																																
<p><b>For MDS-B-V1/V2</b></p> <p>Select the special servo functions.</p> <table style="width: 100%; text-align: center; border-collapse: collapse;"> <tr> <td style="border: none;">F</td><td style="border: none;">E</td><td style="border: none;">D</td><td style="border: none;">C</td><td style="border: none;">B</td><td style="border: none;">A</td><td style="border: none;">9</td><td style="border: none;">8</td> </tr> <tr> <td style="border: 1px solid black;">aft</td><td style="border: 1px solid black;">zrn2</td><td style="border: 1px solid black;">afrg</td><td style="border: 1px solid black;">afse</td><td style="border: 1px solid black;">ovs2</td><td style="border: 1px solid black;">ovs1</td><td style="border: 1px solid black;">lmc2</td><td style="border: 1px solid black;">lmc1</td> </tr> <tr> <td style="border: none;">7</td><td style="border: none;">6</td><td style="border: none;">5</td><td style="border: none;">4</td><td style="border: none;">3</td><td style="border: none;">2</td><td style="border: none;">1</td><td style="border: none;">0</td> </tr> <tr> <td style="border: 1px solid black;"></td><td style="border: 1px solid black;"></td><td style="border: 1px solid black;">vfct2</td><td style="border: 1px solid black;">vfct1</td><td style="border: 1px solid black;"></td><td style="border: 1px solid black;">upc</td><td style="border: 1px solid black;">vcnt2</td><td style="border: 1px solid black;">vcnt1</td> </tr> </table>				F	E	D	C	B	A	9	8	aft	zrn2	afrg	afse	ovs2	ovs1	lmc2	lmc1	7	6	5	4	3	2	1	0			vfct2	vfct1		upc	vcnt2	vcnt1																																
F	E	D	C	B	A	9	8																																																												
aft	zrn2	afrg	afse	ovs2	ovs1	lmc2	lmc1																																																												
7	6	5	4	3	2	1	0																																																												
		vfct2	vfct1		upc	vcnt2	vcnt1																																																												
<table border="1" style="width: 100%; border-collapse: collapse;"> <thead> <tr> <th style="width: 5%;">bit</th> <th style="width: 10%;">Name</th> <th style="width: 35%;">Meaning when set to 0</th> <th style="width: 50%;">Meaning when set to 1</th> </tr> </thead> <tbody> <tr> <td>0</td> <td>vcnt1</td> <td colspan="2">This prevents overshooting and limited cycles, etc., during the closed loop. Use this in combination with SV007 (VIL).</td> </tr> <tr> <td>1</td> <td>vcnt2</td> <td colspan="2">00: Delay compensation changeover invalid 01: Delay compensation changeover type 1 10: Delay compensation changeover type 2 11: Reserved</td> </tr> <tr> <td>2</td> <td>upc</td> <td>Starting torque compensation invalid</td> <td>Starting torque compensation valid</td> </tr> <tr> <td>3</td> <td></td> <td></td> <td></td> </tr> <tr> <td>4</td> <td>vfct1</td> <td colspan="2">00: Jitter compensation invalid</td> </tr> <tr> <td>5</td> <td>vfct2</td> <td colspan="2">01: Jitter compensation 1 pulse 10: Jitter compensation 2 pulse 11: Jitter compensation 3 pulse</td> </tr> <tr> <td>6</td> <td></td> <td></td> <td></td> </tr> <tr> <td>7</td> <td></td> <td></td> <td></td> </tr> <tr> <td>8</td> <td>lmc1</td> <td colspan="2" rowspan="2">Set the compensation gain with SV016 (LMC1) and SV041 (LMC2). 00: Lost motion compensation invalid 01: Lost motion compensation type 1 10: Lost motion compensation type 2 11: Reserved</td> </tr> <tr> <td>9</td> <td>lmc2</td> </tr> <tr> <td>A</td> <td>ovs1</td> <td colspan="2" rowspan="3">00: Overshoot compensation invalid 01: Overshoot compensation type 1 10: Overshoot compensation type 2 11: Overshoot compensation type 3</td> </tr> <tr> <td>B</td> <td>ovs2</td> </tr> <tr> <td>C</td> <td>afse</td> <td>Set for normal use</td> <td>Increases adaptive filter sensitivity <b>(Note 1)</b></td> </tr> <tr> <td>D</td> <td>afrg</td> <td>Set for normal use</td> <td>Set this if the adaptive filter is effective in the speed range. <b>(Note 1)</b></td> </tr> <tr> <td>E</td> <td>zrn2</td> <td>Reference point return type 1</td> <td>Reference point return type 2</td> </tr> <tr> <td>F</td> <td>aflt</td> <td>Adaptive filter invalid</td> <td>Adaptive filter valid If the machine vibrates, the resonance frequency is detected, and the filter is automatically set to eliminate the vibration. This is effective for resonance of 100Hz or more.</td> </tr> </tbody> </table>				bit	Name	Meaning when set to 0	Meaning when set to 1	0	vcnt1	This prevents overshooting and limited cycles, etc., during the closed loop. Use this in combination with SV007 (VIL).		1	vcnt2	00: Delay compensation changeover invalid 01: Delay compensation changeover type 1 10: Delay compensation changeover type 2 11: Reserved		2	upc	Starting torque compensation invalid	Starting torque compensation valid	3				4	vfct1	00: Jitter compensation invalid		5	vfct2	01: Jitter compensation 1 pulse 10: Jitter compensation 2 pulse 11: Jitter compensation 3 pulse		6				7				8	lmc1	Set the compensation gain with SV016 (LMC1) and SV041 (LMC2). 00: Lost motion compensation invalid 01: Lost motion compensation type 1 10: Lost motion compensation type 2 11: Reserved		9	lmc2	A	ovs1	00: Overshoot compensation invalid 01: Overshoot compensation type 1 10: Overshoot compensation type 2 11: Overshoot compensation type 3		B	ovs2	C	afse	Set for normal use	Increases adaptive filter sensitivity <b>(Note 1)</b>	D	afrg	Set for normal use	Set this if the adaptive filter is effective in the speed range. <b>(Note 1)</b>	E	zrn2	Reference point return type 1	Reference point return type 2	F	aflt	Adaptive filter invalid	Adaptive filter valid If the machine vibrates, the resonance frequency is detected, and the filter is automatically set to eliminate the vibration. This is effective for resonance of 100Hz or more.
bit	Name	Meaning when set to 0	Meaning when set to 1																																																																
0	vcnt1	This prevents overshooting and limited cycles, etc., during the closed loop. Use this in combination with SV007 (VIL).																																																																	
1	vcnt2	00: Delay compensation changeover invalid 01: Delay compensation changeover type 1 10: Delay compensation changeover type 2 11: Reserved																																																																	
2	upc	Starting torque compensation invalid	Starting torque compensation valid																																																																
3																																																																			
4	vfct1	00: Jitter compensation invalid																																																																	
5	vfct2	01: Jitter compensation 1 pulse 10: Jitter compensation 2 pulse 11: Jitter compensation 3 pulse																																																																	
6																																																																			
7																																																																			
8	lmc1	Set the compensation gain with SV016 (LMC1) and SV041 (LMC2). 00: Lost motion compensation invalid 01: Lost motion compensation type 1 10: Lost motion compensation type 2 11: Reserved																																																																	
9	lmc2																																																																		
A	ovs1	00: Overshoot compensation invalid 01: Overshoot compensation type 1 10: Overshoot compensation type 2 11: Overshoot compensation type 3																																																																	
B	ovs2																																																																		
C	afse			Set for normal use	Increases adaptive filter sensitivity <b>(Note 1)</b>																																																														
D	afrg	Set for normal use	Set this if the adaptive filter is effective in the speed range. <b>(Note 1)</b>																																																																
E	zrn2	Reference point return type 1	Reference point return type 2																																																																
F	aflt	Adaptive filter invalid	Adaptive filter valid If the machine vibrates, the resonance frequency is detected, and the filter is automatically set to eliminate the vibration. This is effective for resonance of 100Hz or more.																																																																
<p><b>(Note 1)</b> When setting afrg (bitD) to "1", also set afse (bitC) to "1".</p>																																																																			
<p>(Continued on the next page.)</p>																																																																			

**4.7 Servo Parameters**  
**4.7.1 Servo Parameters**

No.	Item	Details	Setting range (unit)																																																																				
2227	SV027	SSF1 Special servo function 1	0000 to FFFF HEX setting																																																																				
<p><b>For MDS-B-SVJ2</b> (Continued from the previous page.)</p> <p>Select the special servo functions.</p> <table style="width: 100%; text-align: center; border-collapse: collapse;"> <tr> <td style="border: none;">F</td><td style="border: none;">E</td><td style="border: none;">D</td><td style="border: none;">C</td><td style="border: none;">B</td><td style="border: none;">A</td><td style="border: none;">9</td><td style="border: none;">8</td> </tr> <tr> <td style="border: 1px solid black;">aflt</td><td style="border: 1px solid black;">zrn2</td><td style="border: 1px solid black;"></td><td style="border: 1px solid black;"></td><td style="border: 1px solid black;">ovs2</td><td style="border: 1px solid black;">ovs1</td><td style="border: 1px solid black;">lmc2</td><td style="border: 1px solid black;">lmc1</td> </tr> <tr> <td style="border: none;">7</td><td style="border: none;">6</td><td style="border: none;">5</td><td style="border: none;">4</td><td style="border: none;">3</td><td style="border: none;">2</td><td style="border: none;">1</td><td style="border: none;">0</td> </tr> <tr> <td style="border: 1px solid black;"></td><td style="border: 1px solid black;"></td><td style="border: 1px solid black;">vfct2</td><td style="border: 1px solid black;">vfct1</td><td style="border: 1px solid black;"></td><td style="border: 1px solid black;"></td><td style="border: 1px solid black;"></td><td style="border: 1px solid black;"></td> </tr> </table>				F	E	D	C	B	A	9	8	aflt	zrn2			ovs2	ovs1	lmc2	lmc1	7	6	5	4	3	2	1	0			vfct2	vfct1																																								
F	E	D	C	B	A	9	8																																																																
aflt	zrn2			ovs2	ovs1	lmc2	lmc1																																																																
7	6	5	4	3	2	1	0																																																																
		vfct2	vfct1																																																																				
<table border="1" style="width: 100%; border-collapse: collapse;"> <thead> <tr> <th style="width: 5%;">bit</th> <th style="width: 15%;">Name</th> <th style="width: 40%;">Meaning when set to 0</th> <th style="width: 40%;">Meaning when set to 1</th> </tr> </thead> <tbody> <tr><td>0</td><td></td><td></td><td></td></tr> <tr><td>1</td><td></td><td></td><td></td></tr> <tr><td>2</td><td></td><td></td><td></td></tr> <tr><td>3</td><td></td><td></td><td></td></tr> <tr><td>4</td><td>vfct1</td><td>00: Jitter compensation invalid</td><td></td></tr> <tr><td>5</td><td>vfct2</td><td>01: Jitter compensation 1 pulse 10: Jitter compensation 2 pulse 11: Jitter compensation 3 pulse</td><td></td></tr> <tr><td>6</td><td></td><td></td><td></td></tr> <tr><td>7</td><td></td><td></td><td></td></tr> <tr><td>8</td><td>lmc1</td><td colspan="2">Set the compensation gain with SV016 (LMC1) and SV041 (LMC2).</td></tr> <tr><td>9</td><td>lmc2</td><td colspan="2">00: Lost motion compensation invalid 01: Lost motion compensation type 1 10: Lost motion compensation type 2 11: Reserved</td></tr> <tr><td>A</td><td>ovs1</td><td colspan="2">00: Overshoot compensation invalid</td></tr> <tr><td>B</td><td>ovs2</td><td colspan="2">01: Overshoot compensation type 1 10: Overshoot compensation type 2 11: Overshoot compensation type 3</td></tr> <tr><td>C</td><td></td><td></td><td></td></tr> <tr><td>D</td><td></td><td></td><td></td></tr> <tr><td>E</td><td>zrn2</td><td colspan="2">Set "1".</td></tr> <tr><td>F</td><td>aflt</td><td>Adaptive filter stop</td><td>Adaptive filter start</td></tr> </tbody> </table>				bit	Name	Meaning when set to 0	Meaning when set to 1	0				1				2				3				4	vfct1	00: Jitter compensation invalid		5	vfct2	01: Jitter compensation 1 pulse 10: Jitter compensation 2 pulse 11: Jitter compensation 3 pulse		6				7				8	lmc1	Set the compensation gain with SV016 (LMC1) and SV041 (LMC2).		9	lmc2	00: Lost motion compensation invalid 01: Lost motion compensation type 1 10: Lost motion compensation type 2 11: Reserved		A	ovs1	00: Overshoot compensation invalid		B	ovs2	01: Overshoot compensation type 1 10: Overshoot compensation type 2 11: Overshoot compensation type 3		C				D				E	zrn2	Set "1".		F	aflt	Adaptive filter stop	Adaptive filter start
bit	Name	Meaning when set to 0	Meaning when set to 1																																																																				
0																																																																							
1																																																																							
2																																																																							
3																																																																							
4	vfct1	00: Jitter compensation invalid																																																																					
5	vfct2	01: Jitter compensation 1 pulse 10: Jitter compensation 2 pulse 11: Jitter compensation 3 pulse																																																																					
6																																																																							
7																																																																							
8	lmc1	Set the compensation gain with SV016 (LMC1) and SV041 (LMC2).																																																																					
9	lmc2	00: Lost motion compensation invalid 01: Lost motion compensation type 1 10: Lost motion compensation type 2 11: Reserved																																																																					
A	ovs1	00: Overshoot compensation invalid																																																																					
B	ovs2	01: Overshoot compensation type 1 10: Overshoot compensation type 2 11: Overshoot compensation type 3																																																																					
C																																																																							
D																																																																							
E	zrn2	Set "1".																																																																					
F	aflt	Adaptive filter stop	Adaptive filter start																																																																				
<p><b>(Note)</b> Set "0" in bits with no particular description.</p> <p>(Continued on the next page.)</p>																																																																							

**4.7 Servo Parameters**  
**4.7.1 Servo Parameters**

No.	Item		Details	Setting range (unit)																																																																																						
2227	SV027	SSF1	Special servo function 1	0000 to FFFF HEX setting																																																																																						
<p><b>For intelligent servo</b> (Continued from the previous page.)</p> <p>Select the special servo function selection.</p> <p style="text-align: center;">F   E   D   C   B   A   9   8</p> <table border="1" style="margin-left: auto; margin-right: auto;"> <tr> <td style="width: 20px;"></td> <td style="width: 20px;">zrn2</td> <td style="width: 20px;"></td> <td style="width: 20px;"></td> <td style="width: 20px;"></td> <td style="width: 20px;"></td> <td style="width: 20px;">lmc2</td> <td style="width: 20px;">lmc1</td> </tr> </table> <p style="text-align: center;">7   6   5   4   3   2   1   0</p> <table border="1" style="margin-left: auto; margin-right: auto;"> <tr> <td style="width: 20px;"></td> <td style="width: 20px;"></td> <td style="width: 20px;">vfct2</td> <td style="width: 20px;">vfct1</td> <td style="width: 20px;"></td> <td style="width: 20px;"></td> <td style="width: 20px;"></td> <td style="width: 20px;"></td> </tr> </table> <table border="1" style="margin-left: auto; margin-right: auto;"> <thead> <tr> <th style="text-align: center;">bit</th> <th style="text-align: center;">Name</th> <th style="text-align: center;">Meaning when set to 0</th> <th style="text-align: center;">Meaning when set to 1</th> </tr> </thead> <tbody> <tr><td style="text-align: center;">0</td><td></td><td></td><td></td></tr> <tr><td style="text-align: center;">1</td><td></td><td></td><td></td></tr> <tr><td style="text-align: center;">2</td><td></td><td></td><td></td></tr> <tr><td style="text-align: center;">3</td><td></td><td></td><td></td></tr> <tr> <td style="text-align: center;">4</td> <td style="text-align: center;">vfct1</td> <td colspan="2">00: Jitter compensation invalid</td> </tr> <tr> <td style="text-align: center;">5</td> <td style="text-align: center;">vfct2</td> <td colspan="2">01: Jitter compensation 1 pulse 10: Jitter compensation 2 pulse 11: Jitter compensation 3 pulse</td> </tr> <tr><td style="text-align: center;">6</td><td></td><td></td><td></td></tr> <tr><td style="text-align: center;">7</td><td></td><td></td><td></td></tr> <tr> <td style="text-align: center;">8</td> <td style="text-align: center;">lmc1</td> <td colspan="2" rowspan="2">Set the compensation gain with SV016 (LMC1) and SV041 (LMC2).</td> </tr> <tr> <td style="text-align: center;">9</td> <td style="text-align: center;">lmc2</td> </tr> <tr> <td></td> <td></td> <td colspan="2">00: Lost motion compensation invalid 01: Lost motion compensation type 1 10: Lost motion compensation type 2 11: Reserved</td> </tr> <tr><td style="text-align: center;">A</td><td></td><td></td><td></td></tr> <tr><td style="text-align: center;">B</td><td></td><td></td><td></td></tr> <tr><td style="text-align: center;">C</td><td></td><td></td><td></td></tr> <tr><td style="text-align: center;">D</td><td></td><td></td><td></td></tr> <tr> <td style="text-align: center;">E</td> <td style="text-align: center;">zrn2</td> <td colspan="2">Set "1".</td> </tr> <tr><td style="text-align: center;">F</td><td></td><td></td><td></td></tr> </tbody> </table> <p><b>(Note)</b> Set "0" in bits with no particular description.</p>					zrn2					lmc2	lmc1			vfct2	vfct1					bit	Name	Meaning when set to 0	Meaning when set to 1	0				1				2				3				4	vfct1	00: Jitter compensation invalid		5	vfct2	01: Jitter compensation 1 pulse 10: Jitter compensation 2 pulse 11: Jitter compensation 3 pulse		6				7				8	lmc1	Set the compensation gain with SV016 (LMC1) and SV041 (LMC2).		9	lmc2			00: Lost motion compensation invalid 01: Lost motion compensation type 1 10: Lost motion compensation type 2 11: Reserved		A				B				C				D				E	zrn2	Set "1".		F				
	zrn2					lmc2	lmc1																																																																																			
		vfct2	vfct1																																																																																							
bit	Name	Meaning when set to 0	Meaning when set to 1																																																																																							
0																																																																																										
1																																																																																										
2																																																																																										
3																																																																																										
4	vfct1	00: Jitter compensation invalid																																																																																								
5	vfct2	01: Jitter compensation 1 pulse 10: Jitter compensation 2 pulse 11: Jitter compensation 3 pulse																																																																																								
6																																																																																										
7																																																																																										
8	lmc1	Set the compensation gain with SV016 (LMC1) and SV041 (LMC2).																																																																																								
9	lmc2																																																																																									
		00: Lost motion compensation invalid 01: Lost motion compensation type 1 10: Lost motion compensation type 2 11: Reserved																																																																																								
A																																																																																										
B																																																																																										
C																																																																																										
D																																																																																										
E	zrn2	Set "1".																																																																																								
F																																																																																										
2228	SV028		(Not used.)	Not used.																																																																																						
2229	SV029	VCS	Speed loop gain decrease starting speed	0 to 9999 (r/min)																																																																																						
<p>If the noise is bothersome during high-speed rotation, such as rapid traverse, set the speed loop gain's drop start motor speed. The target loop gain of the speed loop gain drop is set in SV06 (VGN2). Set to 0 when not using this function.</p>																																																																																										

**4.7 Servo Parameters**  
**4.7.1 Servo Parameters**

No.	Item			Details	Setting range (unit)
2230	SV030	IVC		<b>For MDS-B-V1/V2</b> <ul style="list-style-type: none"> <li>• Voltage non-sensitive band compensation: The low-order 8 bits are used.</li> <li>• Current bias: The high-order 8 bits are used. (Icx) This is used in combination with the SV040 and SV045 high-order 8 bits.</li> </ul>	-32768 to 32767
				<b>For intelligent servo</b> <ul style="list-style-type: none"> <li>• Voltage command bias amount: The low-order 8 bits are used. Normally, set this to "0". Set this to "20" to use the function.</li> <li>• Minute torque compensation amount Cx: The high-order 8 bits are used. Normally, set this to "0". Set this to "255" to use the function.</li> </ul> <p>When setting the low-order 8 bits to 20, and the high-order 8 bits to 255:  <math>255 \times 256 + 20 = 65300 \quad 65300 - 65536 = -236</math></p>	
2231	SV031	OVS1	Overshoot compensation gain 1	<p>Set this parameter if overshooting during deceleration/stop using submicron or closed control. (This parameter is valid when SSF1 - bitA is set to 1.)</p> <p>The overshoot is improved more as the set value is larger.  Set 2 to 10 (%) for normal operation. (Ratio to stall rated current)  (Increase the set value in increments of 2% until a value which suppresses overshoot is found.)  This is valid only when overshoot compensation SV027 (SSF1/ovs1, ovs2) is selected.</p>	-1 to 100 (Stall rated current %)
2232	SV032	TOF	Torque offset compensation gain	<p>Set the unbalance torque amount of an axis having an unbalanced torque such as a vertical axis, as a percentage in respect to the stall rated current.  This is used when SSF1 lmc1, lmc2 or SSF1 vcnt1, vcnt2 (when using MDS-B-V1/V2) is set.</p>	-100 to 100 (Stall rated current %)

**4.7 Servo Parameters**  
**4.7.1 Servo Parameters**

No.	Item	Details	Setting range (unit)					
2233	SV033	SSF2	Special servo function 2					
				<b>For MDS-B-V1/V2</b>		0000 to FFFF HEX setting		
				Select the special servo functions.				
				F   E   D   C   B   A   9   8				
				dos	dis			
				7   6   5   4   3   2   1   0				
				nfd	zck			
				bit	Name		Meaning when set to 0	Meaning when set to 1
				0	zck		Z phase check valid (part of alarm 42)	Z phase check invalid
				1	nfd		Adjust the damping amount of the machine resonance suppression filter.	
2		When the setting value is increased, the effect of the machine resonance suppression filter will drop, and the effect of onto the speed control will drop. 000: ∞      001: -18dB    010: -12dB    011: -9dB 100: -6dB    101: -4dB     110: -3dB     111: -1dB						
3								
4								
5								
6								
7								
8	dis	Digital signal input selection Set 0000.						
9								
A								
B								
C	dos	Digital signal output selection 0000: The MP scale absolute position detection system offset request signal is output. 0001: The specified speed signal is output.						
D								
E								
F								
<b>(Note)</b> Set "0" in bits with no particular description.								
(Continued on the next page.)								

**4.7 Servo Parameters**  
**4.7.1 Servo Parameters**

No.	Item	Details	Setting range (unit)																																																																																																										
2233	SV033	SSF2	Special Servo function 2																																																																																																										
				<div style="border: 1px solid black; padding: 5px;"> <p><b>For MDS-B-SVJ2</b> (Continued from the previous page.)</p> <p>Select the special servo functions.</p> <table style="width: 100%; border-collapse: collapse;"> <tr> <td style="text-align: center;">F</td><td style="text-align: center;">E</td><td style="text-align: center;">D</td><td style="text-align: center;">C</td><td style="text-align: center;">B</td><td style="text-align: center;">A</td><td style="text-align: center;">9</td><td style="text-align: center;">8</td> </tr> <tr> <td style="border: 1px solid black; width: 20px; height: 20px;"></td> <td style="border: 1px solid black; width: 20px; height: 20px;"></td> <td style="border: 1px solid black; width: 20px; height: 20px;"></td> <td style="border: 1px solid black; width: 20px; height: 20px;"></td> <td style="border: 1px solid black; width: 20px; height: 20px;"></td> <td style="border: 1px solid black; width: 20px; height: 20px;"></td> <td style="border: 1px solid black; width: 20px; height: 20px;"></td> <td style="border: 1px solid black; width: 20px; height: 20px;"></td> </tr> <tr> <td colspan="7" style="text-align: center;">afs</td> </tr> </table>   <table style="width: 100%; border-collapse: collapse;"> <tr> <td style="text-align: center;">7</td><td style="text-align: center;">6</td><td style="text-align: center;">5</td><td style="text-align: center;">4</td><td style="text-align: center;">3</td><td style="text-align: center;">2</td><td style="text-align: center;">1</td><td style="text-align: center;">0</td> </tr> <tr> <td style="border: 1px solid black; width: 20px; height: 20px;"></td> <td style="border: 1px solid black; width: 20px; height: 20px;"></td> <td style="border: 1px solid black; width: 20px; height: 20px;"></td> <td style="border: 1px solid black; width: 20px; height: 20px;"></td> <td style="border: 1px solid black; width: 20px; height: 20px;"></td> <td style="border: 1px solid black; width: 20px; height: 20px;"></td> <td style="border: 1px solid black; width: 20px; height: 20px;"></td> <td style="border: 1px solid black; width: 20px; height: 20px;"></td> </tr> <tr> <td colspan="7" style="text-align: center;">nfd</td> </tr> </table> <table border="1" style="width: 100%; border-collapse: collapse; margin-top: 5px;"> <thead> <tr> <th style="width: 5%;">bit</th> <th style="width: 10%;">Name</th> <th style="width: 40%;">Meaning when set to 0</th> <th style="width: 45%;">Meaning when set to 1</th> </tr> </thead> <tbody> <tr> <td style="text-align: center;">0</td> <td rowspan="4" style="vertical-align: top;">nfd</td> <td rowspan="4">Set the filter depth for the notch filter (SV038: FHz). The control is stabilized by making the filter shallower. Setting values: Depth (dB) 0000: <math>-\infty</math>      0010: -18.1dB    0100: -12.0dB    0110: -8.5dB 1000: -6.0dB      1010: -4.1dB      1100: -2.5dB      1110: -1.2dB</td> <td></td> </tr> <tr><td style="text-align: center;">1</td><td></td></tr> <tr><td style="text-align: center;">2</td><td></td></tr> <tr><td style="text-align: center;">3</td><td></td></tr> <tr><td style="text-align: center;">4</td><td></td><td></td><td></td></tr> <tr><td style="text-align: center;">5</td><td></td><td></td><td></td></tr> <tr><td style="text-align: center;">6</td><td></td><td></td><td></td></tr> <tr><td style="text-align: center;">7</td><td></td><td></td><td></td></tr> <tr> <td style="text-align: center;">8</td> <td rowspan="7" style="vertical-align: top;">afs</td> <td rowspan="7">Set the vibration sensitivity of the adaptive filter. If the filter is not deep enough (generally 70% or more) and the vibration cannot be sufficiently eliminated, raise the value.</td> <td></td> </tr> <tr><td style="text-align: center;">9</td><td></td></tr> <tr><td style="text-align: center;">A</td><td></td></tr> <tr><td style="text-align: center;">B</td><td></td></tr> <tr><td style="text-align: center;">C</td><td></td></tr> <tr><td style="text-align: center;">D</td><td></td></tr> <tr><td style="text-align: center;">E</td><td></td></tr> <tr><td style="text-align: center;">F</td><td></td></tr> </tbody> </table> <p><b>(Note)</b> Set "0" in bits with no particular description.</p> </div>	F	E	D	C	B	A	9	8									afs							7	6	5	4	3	2	1	0									nfd							bit	Name	Meaning when set to 0	Meaning when set to 1	0	nfd	Set the filter depth for the notch filter (SV038: FHz). The control is stabilized by making the filter shallower. Setting values: Depth (dB) 0000: $-\infty$ 0010: -18.1dB    0100: -12.0dB    0110: -8.5dB 1000: -6.0dB      1010: -4.1dB      1100: -2.5dB      1110: -1.2dB		1		2		3		4				5				6				7				8	afs	Set the vibration sensitivity of the adaptive filter. If the filter is not deep enough (generally 70% or more) and the vibration cannot be sufficiently eliminated, raise the value.		9		A		B		C		D		E		F		0000 to FFFF HEX setting										
F	E	D	C	B	A	9	8																																																																																																						
afs																																																																																																													
7	6	5	4	3	2	1	0																																																																																																						
nfd																																																																																																													
bit	Name	Meaning when set to 0	Meaning when set to 1																																																																																																										
0	nfd	Set the filter depth for the notch filter (SV038: FHz). The control is stabilized by making the filter shallower. Setting values: Depth (dB) 0000: $-\infty$ 0010: -18.1dB    0100: -12.0dB    0110: -8.5dB 1000: -6.0dB      1010: -4.1dB      1100: -2.5dB      1110: -1.2dB																																																																																																											
1																																																																																																													
2																																																																																																													
3																																																																																																													
4																																																																																																													
5																																																																																																													
6																																																																																																													
7																																																																																																													
8	afs	Set the vibration sensitivity of the adaptive filter. If the filter is not deep enough (generally 70% or more) and the vibration cannot be sufficiently eliminated, raise the value.																																																																																																											
9																																																																																																													
A																																																																																																													
B																																																																																																													
C																																																																																																													
D																																																																																																													
E																																																																																																													
F																																																																																																													
<div style="border: 1px solid black; padding: 5px;"> <p><b>For intelligent servo</b></p> <p>Select the special servo functions.</p> <table style="width: 100%; border-collapse: collapse;"> <tr> <td style="text-align: center;">F</td><td style="text-align: center;">E</td><td style="text-align: center;">D</td><td style="text-align: center;">C</td><td style="text-align: center;">B</td><td style="text-align: center;">A</td><td style="text-align: center;">9</td><td style="text-align: center;">8</td> </tr> <tr> <td style="border: 1px solid black; width: 20px; height: 20px;"></td> <td style="border: 1px solid black; width: 20px; height: 20px;"></td> <td style="border: 1px solid black; width: 20px; height: 20px;"></td> <td style="border: 1px solid black; width: 20px; height: 20px;"></td> <td style="border: 1px solid black; width: 20px; height: 20px;"></td> <td style="border: 1px solid black; width: 20px; height: 20px;"></td> <td style="border: 1px solid black; width: 20px; height: 20px;"></td> <td style="border: 1px solid black; width: 20px; height: 20px;"></td> </tr> <tr> <td colspan="7" style="text-align: center;">nfd</td> </tr> </table>   <table style="width: 100%; border-collapse: collapse;"> <tr> <td style="text-align: center;">7</td><td style="text-align: center;">6</td><td style="text-align: center;">5</td><td style="text-align: center;">4</td><td style="text-align: center;">3</td><td style="text-align: center;">2</td><td style="text-align: center;">1</td><td style="text-align: center;">0</td> </tr> <tr> <td style="border: 1px solid black; width: 20px; height: 20px;"></td> <td style="border: 1px solid black; width: 20px; height: 20px;"></td> <td style="border: 1px solid black; width: 20px; height: 20px;"></td> <td style="border: 1px solid black; width: 20px; height: 20px;"></td> <td style="border: 1px solid black; width: 20px; height: 20px;"></td> <td style="border: 1px solid black; width: 20px; height: 20px;"></td> <td style="border: 1px solid black; width: 20px; height: 20px;"></td> <td style="border: 1px solid black; width: 20px; height: 20px;"></td> </tr> <tr> <td colspan="7" style="text-align: center;">nfd</td> </tr> </table> <table border="1" style="width: 100%; border-collapse: collapse; margin-top: 5px;"> <thead> <tr> <th style="width: 5%;">bit</th> <th style="width: 10%;">Name</th> <th style="width: 40%;">Meaning when set to 0</th> <th style="width: 45%;">Meaning when set to 1</th> </tr> </thead> <tbody> <tr> <td style="text-align: center;">0</td> <td rowspan="4" style="vertical-align: top;">nfd</td> <td rowspan="4">Set the filter depth for the notch filter (SV038: FHz). The control is stabilized by making the filter shallower. Setting values: Depth (dB) 0000: <math>-\infty</math>      0010: -18.1dB    0100: -12.0dB    0110: -8.5dB 1000: -6.0dB      1010: -4.1dB      1100: -2.5dB      1110: -1.2dB</td> <td></td> </tr> <tr><td style="text-align: center;">1</td><td></td></tr> <tr><td style="text-align: center;">2</td><td></td></tr> <tr><td style="text-align: center;">3</td><td></td></tr> <tr><td style="text-align: center;">4</td><td></td><td></td><td></td></tr> <tr><td style="text-align: center;">5</td><td></td><td></td><td></td></tr> <tr><td style="text-align: center;">6</td><td></td><td></td><td></td></tr> <tr><td style="text-align: center;">7</td><td></td><td></td><td></td></tr> <tr><td style="text-align: center;">8</td><td></td><td></td><td></td></tr> <tr><td style="text-align: center;">9</td><td></td><td></td><td></td></tr> <tr><td style="text-align: center;">A</td><td></td><td></td><td></td></tr> <tr><td style="text-align: center;">B</td><td></td><td></td><td></td></tr> <tr><td style="text-align: center;">C</td><td></td><td></td><td></td></tr> <tr><td style="text-align: center;">D</td><td></td><td></td><td></td></tr> <tr><td style="text-align: center;">E</td><td></td><td></td><td></td></tr> <tr><td style="text-align: center;">F</td><td></td><td></td><td></td></tr> </tbody> </table> <p><b>(Note)</b> Set "0" in bits with no particular description.</p> </div>	F	E	D	C	B	A	9	8									nfd							7	6	5	4	3	2	1	0									nfd							bit	Name	Meaning when set to 0	Meaning when set to 1	0	nfd	Set the filter depth for the notch filter (SV038: FHz). The control is stabilized by making the filter shallower. Setting values: Depth (dB) 0000: $-\infty$ 0010: -18.1dB    0100: -12.0dB    0110: -8.5dB 1000: -6.0dB      1010: -4.1dB      1100: -2.5dB      1110: -1.2dB		1		2		3		4				5				6				7				8				9				A				B				C				D				E				F				
F	E	D	C	B	A	9	8																																																																																																						
nfd																																																																																																													
7	6	5	4	3	2	1	0																																																																																																						
nfd																																																																																																													
bit	Name	Meaning when set to 0	Meaning when set to 1																																																																																																										
0	nfd	Set the filter depth for the notch filter (SV038: FHz). The control is stabilized by making the filter shallower. Setting values: Depth (dB) 0000: $-\infty$ 0010: -18.1dB    0100: -12.0dB    0110: -8.5dB 1000: -6.0dB      1010: -4.1dB      1100: -2.5dB      1110: -1.2dB																																																																																																											
1																																																																																																													
2																																																																																																													
3																																																																																																													
4																																																																																																													
5																																																																																																													
6																																																																																																													
7																																																																																																													
8																																																																																																													
9																																																																																																													
A																																																																																																													
B																																																																																																													
C																																																																																																													
D																																																																																																													
E																																																																																																													
F																																																																																																													



**4.7 Servo Parameters**  
**4.7.1 Servo Parameters**

No.	Item	Details	Setting range (unit)																																																																																														
2234	SV034 SSF3	Special servo function 3	0000 to FFFF HEX setting																																																																																														
<p><b>For MDS-B-V1/V2</b></p> <p>Select the special servo functions.</p> <table style="width: 100%; border-collapse: collapse; margin-bottom: 5px;"> <tr> <td style="text-align: center;">F</td><td style="text-align: center;">E</td><td style="text-align: center;">D</td><td style="text-align: center;">C</td><td style="text-align: center;">B</td><td style="text-align: center;">A</td><td style="text-align: center;">9</td><td style="text-align: center;">8</td> </tr> <tr> <td colspan="8" style="text-align: center; border: 1px solid black;">ovsn</td> </tr> </table> <table style="width: 100%; border-collapse: collapse; margin-bottom: 5px;"> <tr> <td style="text-align: center;">7</td><td style="text-align: center;">6</td><td style="text-align: center;">5</td><td style="text-align: center;">4</td><td style="text-align: center;">3</td><td style="text-align: center;">2</td><td style="text-align: center;">1</td><td style="text-align: center;">0</td> </tr> <tr> <td style="text-align: center; border: 1px solid black;">toff</td><td style="text-align: center; border: 1px solid black;">os2</td><td style="text-align: center; border: 1px solid black;"></td><td style="text-align: center; border: 1px solid black;">dcd</td><td style="text-align: center; border: 1px solid black;"></td><td style="text-align: center; border: 1px solid black;"></td><td style="text-align: center; border: 1px solid black;">has2</td><td style="text-align: center; border: 1px solid black;">has1</td> </tr> </table> <table border="1" style="width: 100%; border-collapse: collapse; margin-top: 5px;"> <thead> <tr> <th style="width: 5%;">bit</th> <th style="width: 10%;">Name</th> <th style="width: 40%;">Meaning when set to 0</th> <th style="width: 45%;">Meaning when set to 1</th> </tr> </thead> <tbody> <tr> <td style="text-align: center;">0</td> <td style="text-align: center;">has1</td> <td>Setting for normal use</td> <td>HAS control 1 valid, high-speed compatible</td> </tr> <tr> <td style="text-align: center;">1</td> <td style="text-align: center;">has2</td> <td>Setting for normal use</td> <td>HAS control 2 valid, overshooting compatible</td> </tr> <tr> <td style="text-align: center;">2</td> <td></td> <td></td> <td></td> </tr> <tr> <td style="text-align: center;">3</td> <td></td> <td></td> <td></td> </tr> <tr> <td style="text-align: center;">4</td> <td style="text-align: center;">dcd</td> <td>Setting for normal use</td> <td>Do not set. (For special applications.)</td> </tr> <tr> <td style="text-align: center;">5</td> <td></td> <td></td> <td></td> </tr> <tr> <td style="text-align: center;">6</td> <td style="text-align: center;">os2</td> <td>Setting for normal use</td> <td>Changes the overspeed detection level. <b>(Note 1)</b></td> </tr> <tr> <td style="text-align: center;">7</td> <td style="text-align: center;">toff</td> <td>Setting for normal use</td> <td>Low-speed serial ABS scale communication OFF <b>(Note 2)</b></td> </tr> <tr> <td style="text-align: center;">8</td> <td></td> <td></td> <td></td> </tr> <tr> <td style="text-align: center;">9</td> <td></td> <td></td> <td></td> </tr> <tr> <td style="text-align: center;">A</td> <td></td> <td></td> <td></td> </tr> <tr> <td style="text-align: center;">B</td> <td></td> <td></td> <td></td> </tr> <tr> <td style="text-align: center;">C</td> <td style="text-align: center;">ovsn</td> <td colspan="2" rowspan="5">Set the overshoot compensation type 3 non-sensitive range.</td> </tr> <tr> <td style="text-align: center;">D</td> <td></td> </tr> <tr> <td style="text-align: center;">E</td> <td></td> </tr> <tr> <td style="text-align: center;">F</td> <td></td> </tr> </tbody> </table> <p><b>(Note 1)</b> The following motors are the targets.  HA200, 300: 2400 → 300r/min  HC53, 103, 153, 203, 353, 453, 153R, 203R: 3600 → 4200r/min</p> <p><b>(Note 2)</b> toff (Bit 7) is for testing purposes. When set to "1", the absolute position cannot be initialized.</p>				F	E	D	C	B	A	9	8	ovsn								7	6	5	4	3	2	1	0	toff	os2		dcd			has2	has1	bit	Name	Meaning when set to 0	Meaning when set to 1	0	has1	Setting for normal use	HAS control 1 valid, high-speed compatible	1	has2	Setting for normal use	HAS control 2 valid, overshooting compatible	2				3				4	dcd	Setting for normal use	Do not set. (For special applications.)	5				6	os2	Setting for normal use	Changes the overspeed detection level. <b>(Note 1)</b>	7	toff	Setting for normal use	Low-speed serial ABS scale communication OFF <b>(Note 2)</b>	8				9				A				B				C	ovsn	Set the overshoot compensation type 3 non-sensitive range.		D		E		F	
F	E	D	C	B	A	9	8																																																																																										
ovsn																																																																																																	
7	6	5	4	3	2	1	0																																																																																										
toff	os2		dcd			has2	has1																																																																																										
bit	Name	Meaning when set to 0	Meaning when set to 1																																																																																														
0	has1	Setting for normal use	HAS control 1 valid, high-speed compatible																																																																																														
1	has2	Setting for normal use	HAS control 2 valid, overshooting compatible																																																																																														
2																																																																																																	
3																																																																																																	
4	dcd	Setting for normal use	Do not set. (For special applications.)																																																																																														
5																																																																																																	
6	os2	Setting for normal use	Changes the overspeed detection level. <b>(Note 1)</b>																																																																																														
7	toff	Setting for normal use	Low-speed serial ABS scale communication OFF <b>(Note 2)</b>																																																																																														
8																																																																																																	
9																																																																																																	
A																																																																																																	
B																																																																																																	
C	ovsn	Set the overshoot compensation type 3 non-sensitive range.																																																																																															
D																																																																																																	
E																																																																																																	
F																																																																																																	
(Continued on the next page.)																																																																																																	

**4.7 Servo Parameters**  
**4.7.1 Servo Parameters**

No.	Item	Details	Setting range (unit)																																																																																																	
2234	SV034 SSF3	Special servo function 3	<b>For MDS-B-SVJ2</b> (Continued from the previous page.) Select the special servo functions. <table style="width: 100%; text-align: center; border-collapse: collapse;"> <tr> <td style="border: 1px solid black; width: 20px;">F</td> <td style="border: 1px solid black; width: 20px;">E</td> <td style="border: 1px solid black; width: 20px;">D</td> <td style="border: 1px solid black; width: 20px;">C</td> <td style="border: 1px solid black; width: 20px;">B</td> <td style="border: 1px solid black; width: 20px;">A</td> <td style="border: 1px solid black; width: 20px;">9</td> <td style="border: 1px solid black; width: 20px;">8</td> </tr> <tr> <td style="border: 1px solid black; width: 20px;"> </td> <td style="border: 1px solid black; width: 20px;"> </td> <td style="border: 1px solid black; width: 20px;"> </td> <td style="border: 1px solid black; width: 20px;"> </td> <td style="border: 1px solid black; width: 20px;"> </td> <td style="border: 1px solid black; width: 20px;"> </td> <td style="border: 1px solid black; width: 20px;"> </td> <td style="border: 1px solid black; width: 20px;"> </td> </tr> <tr> <td style="border: 1px solid black; width: 20px;">7</td> <td style="border: 1px solid black; width: 20px;">6</td> <td style="border: 1px solid black; width: 20px;">5</td> <td style="border: 1px solid black; width: 20px;">4</td> <td style="border: 1px solid black; width: 20px;">3</td> <td style="border: 1px solid black; width: 20px;">2</td> <td style="border: 1px solid black; width: 20px;">1</td> <td style="border: 1px solid black; width: 20px;">0</td> </tr> <tr> <td style="border: 1px solid black; width: 20px;">daf2</td> <td style="border: 1px solid black; width: 20px;">daf1</td> <td style="border: 1px solid black; width: 20px;">dac2</td> <td style="border: 1px solid black; width: 20px;">dac1</td> <td colspan="4" style="border: 1px solid black; text-align: center;">mon</td> </tr> </table>	F	E	D	C	B	A	9	8									7	6	5	4	3	2	1	0	daf2	daf1	dac2	dac1	mon				0000 to FFFF HEX setting																																																																
			F	E	D	C	B	A	9	8																																																																																										
			7	6	5	4	3	2	1	0																																																																																										
			daf2	daf1	dac2	dac1	mon																																																																																													
			<table border="1" style="width: 100%; border-collapse: collapse;"> <thead> <tr> <th style="width: 5%;">bit</th> <th style="width: 15%;">Name</th> <th style="width: 35%;">Meaning when set to 0</th> <th style="width: 45%;">Meaning when set to 1</th> </tr> </thead> <tbody> <tr> <td>0</td> <td rowspan="8">mon</td> <td colspan="2">NC servo monitor MAX current display data changeover.</td> </tr> <tr> <td>1</td> <td colspan="2"></td> </tr> <tr> <td>2</td> <td colspan="2"></td> </tr> <tr> <td>3</td> <td colspan="2"></td> </tr> <tr> <td></td> <td style="text-align: center;"><b>MAX current 1</b></td> <td style="text-align: center;"><b>MAX current 2</b></td> </tr> <tr> <td>0</td> <td>Max. current command value (%) when power is turned ON</td> <td>Max. current command value (%) for 1 second</td> </tr> <tr> <td>1</td> <td>Max. current command value (%) for 1 second</td> <td>Max. current FB value (%) for 1 second</td> </tr> <tr> <td>2</td> <td>Max. current FB value (%) when power is turned ON</td> <td>Max. current FB value (%) for 1 second</td> </tr> <tr> <td>3</td> <td>–</td> <td>–</td> </tr> <tr> <td>4</td> <td>Adaptive filter operation frequency (Hz)</td> <td>Adaptive filter operation gain (%)</td> </tr> <tr> <td>5</td> <td>PN bus voltage (V)</td> <td>Regenerative operation frequency monitor (times/s)</td> </tr> <tr> <td>6</td> <td>–</td> <td>–</td> </tr> <tr> <td>7</td> <td>–</td> <td>–</td> </tr> <tr> <td>8 to F</td> <td colspan="2">Setting prohibited</td> <td></td> </tr> <tr> <td>4</td> <td>dac1</td> <td>D/A output ch.1 overflow setting</td> <td>D/A output ch.1 clamp setting</td> </tr> <tr> <td>5</td> <td>dac2</td> <td>D/A output ch.2 overflow setting</td> <td>D/A output ch.2 clamp setting</td> </tr> <tr> <td>6</td> <td>daf1</td> <td>D/A output ch.1 no filter</td> <td>D/A output ch.1 filter setting</td> </tr> <tr> <td>7</td> <td>daf2</td> <td>D/A output ch.2 no filter</td> <td>D/A output ch.2 filter setting</td> </tr> <tr> <td>8</td> <td></td> <td></td> <td></td> </tr> <tr> <td>9</td> <td></td> <td></td> <td></td> </tr> <tr> <td>A</td> <td></td> <td></td> <td></td> </tr> <tr> <td>B</td> <td></td> <td></td> <td></td> </tr> <tr> <td>C</td> <td></td> <td></td> <td></td> </tr> <tr> <td>D</td> <td></td> <td></td> <td></td> </tr> <tr> <td>E</td> <td></td> <td></td> <td></td> </tr> <tr> <td>F</td> <td></td> <td></td> <td></td> </tr> </tbody> </table>	bit	Name	Meaning when set to 0	Meaning when set to 1	0	mon	NC servo monitor MAX current display data changeover.		1			2			3				<b>MAX current 1</b>	<b>MAX current 2</b>	0	Max. current command value (%) when power is turned ON	Max. current command value (%) for 1 second	1	Max. current command value (%) for 1 second	Max. current FB value (%) for 1 second	2	Max. current FB value (%) when power is turned ON	Max. current FB value (%) for 1 second	3	–	–		4	Adaptive filter operation frequency (Hz)	Adaptive filter operation gain (%)	5	PN bus voltage (V)	Regenerative operation frequency monitor (times/s)	6	–	–	7	–	–	8 to F	Setting prohibited			4	dac1	D/A output ch.1 overflow setting	D/A output ch.1 clamp setting	5	dac2	D/A output ch.2 overflow setting	D/A output ch.2 clamp setting	6	daf1	D/A output ch.1 no filter	D/A output ch.1 filter setting	7	daf2	D/A output ch.2 no filter	D/A output ch.2 filter setting	8				9				A				B				C				D				E				F			
			bit	Name	Meaning when set to 0	Meaning when set to 1																																																																																														
			0	mon	NC servo monitor MAX current display data changeover.																																																																																															
			1																																																																																																	
			2																																																																																																	
3																																																																																																				
	<b>MAX current 1</b>	<b>MAX current 2</b>																																																																																																		
0	Max. current command value (%) when power is turned ON	Max. current command value (%) for 1 second																																																																																																		
1	Max. current command value (%) for 1 second	Max. current FB value (%) for 1 second																																																																																																		
2	Max. current FB value (%) when power is turned ON	Max. current FB value (%) for 1 second																																																																																																		
3	–	–																																																																																																		
4	Adaptive filter operation frequency (Hz)	Adaptive filter operation gain (%)																																																																																																		
5	PN bus voltage (V)	Regenerative operation frequency monitor (times/s)																																																																																																		
6	–	–																																																																																																		
7	–	–																																																																																																		
8 to F	Setting prohibited																																																																																																			
4	dac1	D/A output ch.1 overflow setting	D/A output ch.1 clamp setting																																																																																																	
5	dac2	D/A output ch.2 overflow setting	D/A output ch.2 clamp setting																																																																																																	
6	daf1	D/A output ch.1 no filter	D/A output ch.1 filter setting																																																																																																	
7	daf2	D/A output ch.2 no filter	D/A output ch.2 filter setting																																																																																																	
8																																																																																																				
9																																																																																																				
A																																																																																																				
B																																																																																																				
C																																																																																																				
D																																																																																																				
E																																																																																																				
F																																																																																																				
<p><b>(Note)</b> Set "0" in bits with no particular description.</p>																																																																																																				
<p>(Continued on the next page.)</p>																																																																																																				

**4.7 Servo Parameters**  
**4.7.1 Servo Parameters**

No.	Item	Details	Setting range (unit)																																																																				
2234	SV034	SSF3	Special servo function 3																																																																				
<b>For intelligent servo</b> (Continued from the previous page.) Select the special servo functions.			0000 to FFFF HEX setting																																																																				
<table style="margin: auto; border-collapse: collapse;"> <tr> <td style="padding: 2px 10px;">F</td><td style="padding: 2px 10px;">E</td><td style="padding: 2px 10px;">D</td><td style="padding: 2px 10px;">C</td><td style="padding: 2px 10px;">B</td><td style="padding: 2px 10px;">A</td><td style="padding: 2px 10px;">9</td><td style="padding: 2px 10px;">8</td> </tr> <tr> <td style="border: 1px solid black; width: 20px; height: 15px;"></td><td style="border: 1px solid black; width: 20px; height: 15px;"></td><td style="border: 1px solid black; width: 20px; height: 15px;"></td><td style="border: 1px solid black; width: 20px; height: 15px;"></td><td style="border: 1px solid black; width: 20px; height: 15px;"></td><td style="border: 1px solid black; width: 20px; height: 15px;"></td><td style="border: 1px solid black; width: 20px; height: 15px;"></td><td style="border: 1px solid black; width: 20px; height: 15px;"></td> </tr> </table>			F	E	D	C	B	A	9	8																																																													
F	E	D	C	B	A	9	8																																																																
<table style="margin: auto; border-collapse: collapse;"> <tr> <td style="padding: 2px 10px;">7</td><td style="padding: 2px 10px;">6</td><td style="padding: 2px 10px;">5</td><td style="padding: 2px 10px;">4</td><td style="padding: 2px 10px;">3</td><td style="padding: 2px 10px;">2</td><td style="padding: 2px 10px;">1</td><td style="padding: 2px 10px;">0</td> </tr> <tr> <td style="border: 1px solid black; width: 20px; height: 15px;"></td><td style="border: 1px solid black; width: 20px; height: 15px;">daf1</td><td style="border: 1px solid black; width: 20px; height: 15px;"></td><td style="border: 1px solid black; width: 20px; height: 15px;">dac1</td><td style="border: 1px solid black; width: 20px; height: 15px;"></td><td style="border: 1px solid black; width: 20px; height: 15px;"></td><td style="border: 1px solid black; width: 20px; height: 15px;"></td><td style="border: 1px solid black; width: 20px; height: 15px;">mon</td> </tr> </table>			7	6	5	4	3	2	1	0		daf1		dac1				mon																																																					
7	6	5	4	3	2	1	0																																																																
	daf1		dac1				mon																																																																
<table border="1" style="width: 100%; border-collapse: collapse;"> <thead> <tr> <th style="width: 5%;">bit</th> <th style="width: 10%;">Name</th> <th style="width: 35%;">Meaning when set to 0</th> <th style="width: 50%;">Meaning when set to 1</th> </tr> </thead> <tbody> <tr> <td style="text-align: center;">0</td> <td style="text-align: center;">mon</td> <td>Current command monitor display</td> <td>Current FB monitor display</td> </tr> <tr> <td style="text-align: center;">1</td> <td></td> <td></td> <td></td> </tr> <tr> <td style="text-align: center;">2</td> <td></td> <td></td> <td></td> </tr> <tr> <td style="text-align: center;">3</td> <td></td> <td></td> <td></td> </tr> <tr> <td style="text-align: center;">4</td> <td style="text-align: center;">dac1</td> <td>D/A output ch.1 overflow setting</td> <td>D/A output ch.1 clamp setting</td> </tr> <tr> <td style="text-align: center;">5</td> <td></td> <td></td> <td></td> </tr> <tr> <td style="text-align: center;">6</td> <td style="text-align: center;">daf1</td> <td>D/A output ch.1 no filter</td> <td>D/A output ch.1 filter setting</td> </tr> <tr> <td style="text-align: center;">7</td> <td></td> <td></td> <td></td> </tr> <tr> <td style="text-align: center;">8</td> <td></td> <td></td> <td></td> </tr> <tr> <td style="text-align: center;">9</td> <td></td> <td></td> <td></td> </tr> <tr> <td style="text-align: center;">A</td> <td></td> <td></td> <td></td> </tr> <tr> <td style="text-align: center;">B</td> <td></td> <td></td> <td></td> </tr> <tr> <td style="text-align: center;">C</td> <td></td> <td></td> <td></td> </tr> <tr> <td style="text-align: center;">D</td> <td></td> <td></td> <td></td> </tr> <tr> <td style="text-align: center;">E</td> <td></td> <td></td> <td></td> </tr> <tr> <td style="text-align: center;">F</td> <td></td> <td></td> <td></td> </tr> </tbody> </table>				bit	Name	Meaning when set to 0	Meaning when set to 1	0	mon	Current command monitor display	Current FB monitor display	1				2				3				4	dac1	D/A output ch.1 overflow setting	D/A output ch.1 clamp setting	5				6	daf1	D/A output ch.1 no filter	D/A output ch.1 filter setting	7				8				9				A				B				C				D				E				F			
bit	Name	Meaning when set to 0	Meaning when set to 1																																																																				
0	mon	Current command monitor display	Current FB monitor display																																																																				
1																																																																							
2																																																																							
3																																																																							
4	dac1	D/A output ch.1 overflow setting	D/A output ch.1 clamp setting																																																																				
5																																																																							
6	daf1	D/A output ch.1 no filter	D/A output ch.1 filter setting																																																																				
7																																																																							
8																																																																							
9																																																																							
A																																																																							
B																																																																							
C																																																																							
D																																																																							
E																																																																							
F																																																																							
<p><b>(Note)</b> Set "0" in bits with no particular description.</p>																																																																							

**4.7 Servo Parameters**  
**4.7.1 Servo Parameters**

No.	Item	Details	Setting range (unit)																																																															
2235	SV035	SSF4	Special servo function 4	<b>For MDS-B-V1/V2</b> Select the special servo functions. F   E   D   C   B   A   9   8 <table border="1" style="width: 100%; text-align: center; border-collapse: collapse;"> <tr> <td style="width: 12.5%;">clt</td> <td style="width: 12.5%;">clG1</td> <td style="width: 12.5%;">cl2n</td> <td style="width: 12.5%;">clet</td> <td style="width: 12.5%;">cltq</td> </tr> </table> 7   6   5   4   3   2   1   0 <table border="1" style="width: 100%; text-align: center; border-collapse: collapse;"> <tr> <td style="width: 12.5%;"></td> <td style="width: 12.5%;">iup</td> <td style="width: 12.5%;"></td> <td style="width: 12.5%;"></td> <td style="width: 12.5%;"></td> <td style="width: 12.5%;"></td> <td style="width: 12.5%;">tdt</td> </tr> </table>	clt	clG1	cl2n	clet	cltq		iup					tdt	0000 to FFFF HEX setting																																																	
				clt	clG1	cl2n	clet	cltq																																																										
					iup					tdt																																																								
				<table border="1" style="width: 100%; border-collapse: collapse;"> <thead> <tr> <th style="width: 10%;">bit</th> <th style="width: 10%;">Name</th> <th style="width: 40%;">Meaning when set to 0</th> <th style="width: 40%;">Meaning when set to 1</th> </tr> </thead> <tbody> <tr> <td>0</td> <td rowspan="5">tdt</td> <td colspan="2">Td creation time setting (driver fixed)</td> </tr> <tr> <td>1</td> <td colspan="2">Setting time (<math>\mu</math>s) = (tdt + 1) <math>\times</math> 0.569</td> </tr> <tr> <td>2</td> <td colspan="2">Setting time when "0" is set</td> </tr> <tr> <td>3</td> <td>Less than 7kW: 5.69<math>\mu</math>s</td> <td>7kW or more: 8.52<math>\mu</math>s</td> </tr> <tr> <td>4</td> <td colspan="2">When tdt&lt;9, the setting is handled as tdt = 0.</td> </tr> <tr> <td>5</td> <td colspan="2">Normally, set "0".</td> <td></td> </tr> <tr> <td>6</td> <td>iup</td> <td>Setting for normal use</td> <td>Do not set. (For special applications.)</td> </tr> <tr> <td>7</td> <td></td> <td></td> <td></td> </tr> <tr> <td>8</td> <td rowspan="2">cltq</td> <td colspan="2">Set the deceleration torque for when a collision is detected.</td> </tr> <tr> <td>9</td> <td>00: 100%   01: 90%   10: 80%   11: 70%</td> <td></td> </tr> <tr> <td>A</td> <td>clet</td> <td>Setting for normal use</td> <td>The past two-second estimated disturbance torque peak value is displayed at MPOF on the Servo Monitor screen.</td> </tr> <tr> <td>B</td> <td>cl2n</td> <td>Setting for normal use</td> <td>Collision detection method 2 is invalidated.</td> </tr> <tr> <td>C</td> <td rowspan="3">clG1</td> <td colspan="2">Set the collision detection level for the collision detection method 1, G1 modal.</td> </tr> <tr> <td>D</td> <td colspan="2">When 0 is set : The G1 modal collision detection will not be carried out.</td> </tr> <tr> <td>E</td> <td colspan="2">When 1 to 7 is set: Multiply the value of G0 modal collision detection level (SV060: TLMT) by the set value. The obtained value will become the G1 modal collision detection level.</td> </tr> <tr> <td>F</td> <td>clt</td> <td>Setting for normal use</td> <td>The guide value for the SV059 (TCNV) setting value is displayed at MPOF on the Servo Monitor screen.</td> </tr> </tbody> </table>	bit	Name	Meaning when set to 0	Meaning when set to 1	0	tdt	Td creation time setting (driver fixed)		1	Setting time ( $\mu$ s) = (tdt + 1) $\times$ 0.569		2		Setting time when "0" is set		3	Less than 7kW: 5.69 $\mu$ s	7kW or more: 8.52 $\mu$ s	4	When tdt<9, the setting is handled as tdt = 0.		5	Normally, set "0".			6	iup	Setting for normal use	Do not set. (For special applications.)	7				8	cltq	Set the deceleration torque for when a collision is detected.		9	00: 100%   01: 90%   10: 80%   11: 70%		A	clet	Setting for normal use	The past two-second estimated disturbance torque peak value is displayed at MPOF on the Servo Monitor screen.	B	cl2n	Setting for normal use	Collision detection method 2 is invalidated.	C	clG1	Set the collision detection level for the collision detection method 1, G1 modal.		D	When 0 is set : The G1 modal collision detection will not be carried out.		E	When 1 to 7 is set: Multiply the value of G0 modal collision detection level (SV060: TLMT) by the set value. The obtained value will become the G1 modal collision detection level.		F	clt	Setting for normal use	The guide value for the SV059 (TCNV) setting value is displayed at MPOF on the Servo Monitor screen.
				bit	Name	Meaning when set to 0	Meaning when set to 1																																																											
				0	tdt	Td creation time setting (driver fixed)																																																												
				1		Setting time ( $\mu$ s) = (tdt + 1) $\times$ 0.569																																																												
				2		Setting time when "0" is set																																																												
				3		Less than 7kW: 5.69 $\mu$ s	7kW or more: 8.52 $\mu$ s																																																											
				4		When tdt<9, the setting is handled as tdt = 0.																																																												
5	Normally, set "0".																																																																	
6	iup	Setting for normal use	Do not set. (For special applications.)																																																															
7																																																																		
8	cltq	Set the deceleration torque for when a collision is detected.																																																																
9		00: 100%   01: 90%   10: 80%   11: 70%																																																																
A	clet	Setting for normal use	The past two-second estimated disturbance torque peak value is displayed at MPOF on the Servo Monitor screen.																																																															
B	cl2n	Setting for normal use	Collision detection method 2 is invalidated.																																																															
C	clG1	Set the collision detection level for the collision detection method 1, G1 modal.																																																																
D		When 0 is set : The G1 modal collision detection will not be carried out.																																																																
E		When 1 to 7 is set: Multiply the value of G0 modal collision detection level (SV060: TLMT) by the set value. The obtained value will become the G1 modal collision detection level.																																																																
F	clt	Setting for normal use	The guide value for the SV059 (TCNV) setting value is displayed at MPOF on the Servo Monitor screen.																																																															
(Continued on the next page.)																																																																		

**4.7 Servo Parameters**  
**4.7.1 Servo Parameters**

No.	Item	Details	Setting range (unit)																																																																																							
2235	SV035	SSF4 Special servo function 4	<b>For intelligent servo</b> (Continued from the previous page.) Select the special servo functions. F   E   D   C   B   A   9   8 <table border="1" style="width: 100%; text-align: center; border-collapse: collapse;"> <tr> <td style="width: 12.5%;">clt</td> <td style="width: 12.5%;">clG1</td> <td style="width: 12.5%;">cl2n</td> <td style="width: 12.5%;">clet</td> <td style="width: 12.5%;"></td> <td style="width: 12.5%;"></td> <td style="width: 12.5%;"></td> <td style="width: 12.5%;"></td> </tr> <tr> <td style="width: 12.5%;">7</td> <td style="width: 12.5%;">6</td> <td style="width: 12.5%;">5</td> <td style="width: 12.5%;">4</td> <td style="width: 12.5%;">3</td> <td style="width: 12.5%;">2</td> <td style="width: 12.5%;">1</td> <td style="width: 12.5%;">0</td> </tr> <tr> <td style="width: 12.5%;"></td> <td style="width: 12.5%;"></td> <td style="width: 12.5%;"></td> <td style="width: 12.5%;"></td> <td style="width: 12.5%;"></td> <td style="width: 12.5%;"></td> <td style="width: 12.5%;"></td> <td style="width: 12.5%;"></td> </tr> </table> <table border="1" style="width: 100%; text-align: center; border-collapse: collapse;"> <thead> <tr> <th style="width: 10%;">bit</th> <th style="width: 15%;">Name</th> <th style="width: 35%;">Meaning when set to 0</th> <th style="width: 40%;">Meaning when set to 1</th> </tr> </thead> <tbody> <tr><td>0</td><td></td><td></td><td></td></tr> <tr><td>1</td><td></td><td></td><td></td></tr> <tr><td>2</td><td></td><td></td><td></td></tr> <tr><td>3</td><td></td><td></td><td></td></tr> <tr><td>4</td><td></td><td></td><td></td></tr> <tr><td>5</td><td></td><td></td><td></td></tr> <tr><td>6</td><td></td><td></td><td></td></tr> <tr><td>7</td><td></td><td></td><td></td></tr> <tr><td>8</td><td></td><td></td><td></td></tr> <tr><td>9</td><td></td><td></td><td></td></tr> <tr> <td>A</td> <td>clet</td> <td>Setting for normal use</td> <td>The past two-second estimated disturbance torque peak value is displayed at MPOF on the Servo Monitor screen.</td> </tr> <tr> <td>B</td> <td>cl2n</td> <td>Setting for normal use</td> <td>When the current reaches the driver's maximum capacity while using the collision detection function, the function to decelerate and stop will be invalidated.</td> </tr> <tr> <td>C</td> <td rowspan="3">clG1</td> <td rowspan="3">Set the collision detection level for the collision detection method 1, G1 modal. When 0 is set : The G1 modal collision detection will not be carried out. When 1 to 7 is set: Multiply the value of G0 modal collision detection level (SV060: TLMT) by the set value.</td> <td rowspan="3"></td> </tr> <tr><td>D</td></tr> <tr><td>E</td></tr> <tr> <td>F</td> <td>clt</td> <td>Setting for normal use</td> <td>The guide value for the SV059 (TCNV) setting value is displayed at MPOF on the Servo Monitor screen.</td> </tr> </tbody> </table>	clt	clG1	cl2n	clet					7	6	5	4	3	2	1	0									bit	Name	Meaning when set to 0	Meaning when set to 1	0				1				2				3				4				5				6				7				8				9				A	clet	Setting for normal use	The past two-second estimated disturbance torque peak value is displayed at MPOF on the Servo Monitor screen.	B	cl2n	Setting for normal use	When the current reaches the driver's maximum capacity while using the collision detection function, the function to decelerate and stop will be invalidated.	C	clG1	Set the collision detection level for the collision detection method 1, G1 modal. When 0 is set : The G1 modal collision detection will not be carried out. When 1 to 7 is set: Multiply the value of G0 modal collision detection level (SV060: TLMT) by the set value.		D	E	F	clt	Setting for normal use	The guide value for the SV059 (TCNV) setting value is displayed at MPOF on the Servo Monitor screen.	0000 to FFFF HEX setting
			clt	clG1	cl2n	clet																																																																																				
			7	6	5	4	3	2	1	0																																																																																
			bit	Name	Meaning when set to 0	Meaning when set to 1																																																																																				
			0																																																																																							
			1																																																																																							
			2																																																																																							
			3																																																																																							
			4																																																																																							
5																																																																																										
6																																																																																										
7																																																																																										
8																																																																																										
9																																																																																										
A	clet	Setting for normal use	The past two-second estimated disturbance torque peak value is displayed at MPOF on the Servo Monitor screen.																																																																																							
B	cl2n	Setting for normal use	When the current reaches the driver's maximum capacity while using the collision detection function, the function to decelerate and stop will be invalidated.																																																																																							
C	clG1	Set the collision detection level for the collision detection method 1, G1 modal. When 0 is set : The G1 modal collision detection will not be carried out. When 1 to 7 is set: Multiply the value of G0 modal collision detection level (SV060: TLMT) by the set value.																																																																																								
D																																																																																										
E																																																																																										
F	clt	Setting for normal use	The guide value for the SV059 (TCNV) setting value is displayed at MPOF on the Servo Monitor screen.																																																																																							

**4.7 Servo Parameters**  
**4.7.1 Servo Parameters**

No.	Item	Details	Setting range (unit)																																																														
2236	SV036 P TYP*	Power supply type <b>For MDS-B-V1/V2</b> When this unit is a signal connection axis with power supply unit, set this parameter. Set "0" for this parameter for the unit which is not a signal connection axis. When setting this parameter, refer to the table shown below. <div style="text-align: center; margin: 10px 0;"> <table style="margin: auto; border-collapse: collapse;"> <tr> <td style="padding: 0 10px;">F</td><td style="padding: 0 10px;">E</td><td style="padding: 0 10px;">D</td><td style="padding: 0 10px;">C</td><td style="padding: 0 10px;">B</td><td style="padding: 0 10px;">A</td><td style="padding: 0 10px;">9</td><td style="padding: 0 10px;">8</td> </tr> <tr> <td colspan="4" style="border: 1px solid black; text-align: center; padding: 2px;">amp</td> <td colspan="4" style="border: 1px solid black; text-align: center; padding: 2px;">rtyp</td> </tr> <tr> <td colspan="8" style="padding: 10px 0 0 0;">7    6    5    4    3    2    1    0</td> </tr> <tr> <td colspan="8" style="border: 1px solid black; text-align: center; padding: 2px;">ptyp</td> </tr> </table> </div> <table border="1" style="width: 100%; border-collapse: collapse; margin-top: 10px;"> <thead> <tr> <th style="width: 5%;">bit</th> <th style="width: 15%;">Name</th> <th style="width: 35%;">Meaning when set to 0</th> <th style="width: 45%;">Meaning when set to 1</th> </tr> </thead> <tbody> <tr> <td style="text-align: center;">0</td> <td rowspan="8" style="vertical-align: top;">ptyp</td> <td colspan="2" rowspan="8">Set the power supply type. (Select the type from the following table and set.)</td> </tr> <tr> <td style="text-align: center;">1</td> </tr> <tr> <td style="text-align: center;">2</td> </tr> <tr> <td style="text-align: center;">3</td> </tr> <tr> <td style="text-align: center;">4</td> </tr> <tr> <td style="text-align: center;">5</td> </tr> <tr> <td style="text-align: center;">6</td> </tr> <tr> <td style="text-align: center;">7</td> </tr> <tr> <td style="text-align: center;">8</td> <td rowspan="5" style="vertical-align: top;">rtyp</td> <td colspan="2" rowspan="5">Set "0" if the power supply unit is a current regeneration type. If the power supply unit is a resistance regeneration type, set the type of resistor being used. (Select the type from the following table and set.)</td> </tr> <tr> <td style="text-align: center;">9</td> </tr> <tr> <td style="text-align: center;">A</td> </tr> <tr> <td style="text-align: center;">B</td> </tr> <tr> <td style="text-align: center;">C</td> </tr> <tr> <td style="text-align: center;">D</td> <td rowspan="4" style="vertical-align: top;">amp</td> <td colspan="2" rowspan="4">Set the driver model number. 0: MDS-B-V1/V2/SP, MDS-A-V1/V2/SP 1: MDS-A-SVJ 2: MDS-A-SPJ</td> </tr> <tr> <td style="text-align: center;">E</td> </tr> <tr> <td style="text-align: center;">F</td> </tr> <tr> <td style="text-align: center;">F</td> </tr> </tbody> </table>	F	E	D	C	B	A	9	8	amp				rtyp				7    6    5    4    3    2    1    0								ptyp								bit	Name	Meaning when set to 0	Meaning when set to 1	0	ptyp	Set the power supply type. (Select the type from the following table and set.)		1	2	3	4	5	6	7	8	rtyp	Set "0" if the power supply unit is a current regeneration type. If the power supply unit is a resistance regeneration type, set the type of resistor being used. (Select the type from the following table and set.)		9	A	B	C	D	amp	Set the driver model number. 0: MDS-B-V1/V2/SP, MDS-A-V1/V2/SP 1: MDS-A-SVJ 2: MDS-A-SPJ		E	F	F	0000 to FFFF HEX setting
F	E	D	C	B	A	9	8																																																										
amp				rtyp																																																													
7    6    5    4    3    2    1    0																																																																	
ptyp																																																																	
bit	Name	Meaning when set to 0	Meaning when set to 1																																																														
0	ptyp	Set the power supply type. (Select the type from the following table and set.)																																																															
1																																																																	
2																																																																	
3																																																																	
4																																																																	
5																																																																	
6																																																																	
7																																																																	
8	rtyp	Set "0" if the power supply unit is a current regeneration type. If the power supply unit is a resistance regeneration type, set the type of resistor being used. (Select the type from the following table and set.)																																																															
9																																																																	
A																																																																	
B																																																																	
C																																																																	
D	amp	Set the driver model number. 0: MDS-B-V1/V2/SP, MDS-A-V1/V2/SP 1: MDS-A-SVJ 2: MDS-A-SPJ																																																															
E																																																																	
F																																																																	
F																																																																	

(Continued on the next page.)

**4.7 Servo Parameters**  
**4.7.1 Servo Parameters**

No.	Item	Details	Setting range (unit)																																																																																														
2236	SV036	PTYP* Regenerative resistor type	<b>For MDS-B-SVJ2</b> (Continued from the previous page.) <table style="width: 100%; border-collapse: collapse; margin-bottom: 5px;"> <tr> <td style="text-align: center;">F</td><td style="text-align: center;">E</td><td style="text-align: center;">D</td><td style="text-align: center;">C</td><td style="text-align: center;">B</td><td style="text-align: center;">A</td><td style="text-align: center;">9</td><td style="text-align: center;">8</td> </tr> <tr> <td colspan="4" style="text-align: center; border: 1px solid black;">amp</td> <td colspan="4" style="text-align: center; border: 1px solid black;">rtp</td> </tr> </table> <table style="width: 100%; border-collapse: collapse; margin-bottom: 5px;"> <tr> <td style="text-align: center;">7</td><td style="text-align: center;">6</td><td style="text-align: center;">5</td><td style="text-align: center;">4</td><td style="text-align: center;">3</td><td style="text-align: center;">2</td><td style="text-align: center;">1</td><td style="text-align: center;">0</td> </tr> <tr> <td colspan="8" style="text-align: center; border: 1px solid black;">emgx</td> </tr> </table> <table border="1" style="width: 100%; border-collapse: collapse; margin-bottom: 5px;"> <thead> <tr> <th style="width: 5%;">bit</th> <th style="width: 15%;">Name</th> <th style="width: 40%;">Meaning when set to 0</th> <th style="width: 40%;">Meaning when set to 1</th> </tr> </thead> <tbody> <tr> <td>0</td> <td></td> <td colspan="2" rowspan="4">Always set to 0 (0000).</td> </tr> <tr> <td>1</td> <td></td> </tr> <tr> <td>2</td> <td></td> </tr> <tr> <td>3</td> <td></td> </tr> <tr> <td>4</td> <td rowspan="4">emgx</td> <td colspan="2" rowspan="4">Set the external emergency stop function. (Setting is prohibited for values with no descriptions.)</td> </tr> <tr> <td>5</td> </tr> <tr> <td>6</td> <td style="text-align: center;">0</td> <td>External emergency stop invalid</td> </tr> <tr> <td>7</td> <td style="text-align: center;">4</td> <td>External emergency stop valid</td> </tr> <tr> <td>8</td> <td rowspan="7">rtp</td> <td colspan="2" rowspan="7">Set the regenerative resistor type.</td> </tr> <tr> <td>9</td> </tr> <tr> <td>A</td> <td style="text-align: center;">0</td> <td>Amplifier standard built-in resistor (SVJ2-01 has no built-in resistor.)</td> </tr> <tr> <td>B</td> <td style="text-align: center;">1</td> <td>Setting prohibited</td> </tr> <tr> <td></td> <td style="text-align: center;">2</td> <td>MR-RB032 (30W)</td> </tr> <tr> <td></td> <td style="text-align: center;">3</td> <td>MR-RB12 (100W)</td> </tr> <tr> <td></td> <td style="text-align: center;">4</td> <td>MR-RB32 (300W)</td> </tr> <tr> <td></td> <td style="text-align: center;">5</td> <td>MR-RB30 (300W)</td> </tr> <tr> <td></td> <td style="text-align: center;">6</td> <td>MR-RB50 (500W)</td> </tr> <tr> <td></td> <td style="text-align: center;">7 to F</td> <td>Setting prohibited</td> </tr> <tr> <td>C</td> <td rowspan="4">amp</td> <td colspan="2" rowspan="4">Always set to 1 (0001).</td> </tr> <tr> <td>D</td> </tr> <tr> <td>E</td> </tr> <tr> <td>F</td> </tr> </tbody> </table>	F	E	D	C	B	A	9	8	amp				rtp				7	6	5	4	3	2	1	0	emgx								bit	Name	Meaning when set to 0	Meaning when set to 1	0		Always set to 0 (0000).		1		2		3		4	emgx	Set the external emergency stop function. (Setting is prohibited for values with no descriptions.)		5	6	0	External emergency stop invalid	7	4	External emergency stop valid	8	rtp	Set the regenerative resistor type.		9	A	0	Amplifier standard built-in resistor (SVJ2-01 has no built-in resistor.)	B	1	Setting prohibited		2	MR-RB032 (30W)		3	MR-RB12 (100W)		4	MR-RB32 (300W)		5	MR-RB30 (300W)		6	MR-RB50 (500W)		7 to F	Setting prohibited	C	amp	Always set to 1 (0001).		D	E	F	0000 to FFFF HEX setting
			F	E	D	C	B	A	9	8																																																																																							
amp				rtp																																																																																													
7	6	5	4	3	2	1	0																																																																																										
emgx																																																																																																	
bit	Name	Meaning when set to 0	Meaning when set to 1																																																																																														
0		Always set to 0 (0000).																																																																																															
1																																																																																																	
2																																																																																																	
3																																																																																																	
4	emgx	Set the external emergency stop function. (Setting is prohibited for values with no descriptions.)																																																																																															
5																																																																																																	
6				0	External emergency stop invalid																																																																																												
7				4	External emergency stop valid																																																																																												
8	rtp	Set the regenerative resistor type.																																																																																															
9																																																																																																	
A				0	Amplifier standard built-in resistor (SVJ2-01 has no built-in resistor.)																																																																																												
B				1	Setting prohibited																																																																																												
				2	MR-RB032 (30W)																																																																																												
				3	MR-RB12 (100W)																																																																																												
				4	MR-RB32 (300W)																																																																																												
	5	MR-RB30 (300W)																																																																																															
	6	MR-RB50 (500W)																																																																																															
	7 to F	Setting prohibited																																																																																															
C	amp	Always set to 1 (0001).																																																																																															
D																																																																																																	
E																																																																																																	
F																																																																																																	
<b>For intelligent servo</b> <table border="1" style="width: 100%; border-collapse: collapse; margin-top: 5px;"> <thead> <tr> <th style="width: 40%;">Resistor type</th> <th style="width: 60%;">Setting</th> </tr> </thead> <tbody> <tr> <td>Built-in standard</td> <td style="text-align: center;">1000</td> </tr> </tbody> </table>	Resistor type	Setting	Built-in standard	1000	1000																																																																																												
Resistor type	Setting																																																																																																
Built-in standard	1000																																																																																																
2237	SV037	JL Motor conversion inertia amount	Set the load inertia that includes the motor in respect to the motor inertia. $SV037 (JL) = (J_m + J_1) / J_m \times 100$ J <sub>m</sub> : Motor inertia J <sub>1</sub> : Motor axis conversion load inertia	0 to 5000 (%)																																																																																													
2238	SV038	FHz Frequency of machine resonance suppression filter	If machine vibration occurs, set the vibration frequency to be suppressed. Take care for versions up to A/B for MDS-B-V1/V2 that are set to 100 to 140Hz. Set "0" when not using this function.	0 to 3000 (Hz)																																																																																													
2239	SV039	LMCD Lost motion compensation timing	Set when the lost motion compensation timing is not suitable. Adjust upwards in increments of "10".	0 to 2000 (ms)																																																																																													

**4.7 Servo Parameters**  
**4.7.1 Servo Parameters**

No.	Item		Details	Setting range (unit)	
2240	SV040	LMCT	Lost motion compensation dead zone (low-order 8 bits)	The lost motion compensation dead zone can only be set during feed forward control. Set in the low-order 8 bits. When set to "0", 2 $\mu$ m will actually be set. Adjust upwards in increments of 1 $\mu$ m.	-32768 to 32767 <b>(Note)</b> The setting range of the low-order 8 bits is 0 to 100 ( $\mu$ m).
			Current bias (high-order 8 bits)	This is used in combination with high-order 8 bits SV030 and SV045.	
			Feed forward control non-sensitive band	This is valid only during feed forward control. When "0" is set, 2 $\mu$ m will be actually set. Adjust in increments of 1 $\mu$ m. (This is valid only when using SVJ2.)	0 to 100 ( $\mu$ m)
2241	SV041	LMC2	Lost motion compensation gain 2	Normally set this to "0". Set this with SV016 (LMC1) only when setting the lost motion compensation's gain (type 1) or compensation amount (type 2) to different values according to the command direction. <ul style="list-style-type: none"> <li>Set the value for changing the command speed from the - to + direction (during command direction CW) in SV016 (LMC1).</li> <li>Set the value for changing the command speed from the + to - direction (during command direction CW) in SV041 (LMC2).</li> <li>When "-1" is set, compensation will not be carried out when the command speed direction changes. This is valid only when lost motion compensation (SV027: lmc1, lmc2) is selected.</li> </ul>	-1 to 200 (Stall rated current %)
2242	SV042	OVS2	Overshoot compensation gain 2	Overshoot compensation 2 Set the overshoot compensation amount for unidirectional movement (command direction CW). When "0" is set, the value set for SV031 (OVS1) will be set. When "-1" is set, compensation will not be carried out during unidirectional movement. This is valid only when overshoot compensation SV027 (SSF1/OVS1) is selected.	-1 to 200 (Stall rated current %)
2243	SV043	OBS1	Observer 1	Set the pole of the observer. Normally set approximately "628" (rad). To operate the observer function, also set the SV037 (JL) and SV044 (OBS2). Set to "0" when not used.	0 to 1000 (rad)
2244	SV044	OBS2	Observer 2	Set the execution gain of the observer. Normally set to "100". To operate the observer function, also set the SV037 (JL) and SV043 (OBS1). Set to "0" when not used.	0 to 500 (%) For MDS-B-SVJ2: 0 to 1000 (%)
2245	SV045	TRUB	Friction torque (low-order 8 bits)	When using the collision detection function, set the friction torque in the low-order 8 bits with a rate (%) for the stall rated current. Set to "0" when not using the collision detection function.	-32768 to 32767 <b>(Note)</b> The setting range of the low-order 8 bits is 0 to 100 (Stall rated current %).
			Current bias (high-order 8 bits)	This is used in combination with high-order 8 bits of SV030 and SV040.	
2246	SV046			Not used. Set to "0".	0



**4.7 Servo Parameters**  
**4.7.1 Servo Parameters**

No.	Item		Details	Setting range (unit)	
2247	SV047	EC1	Inductive voltage compensation gain	Set the execution gain of the inductive voltage compensation. Normally, set to "100".	-32768 to 32767 (%)
2248	SV048	EMGr	Drop prevention brake operation delay time	Set the brake operation delay time when using the drop prevention function. Set a larger value than the actual brake operation time. Set to "0" when not using the drop prevention function. SV055 (EMGx) and SV056 (EMGt) must also be set when using this function.	0 to 2000 (ms)
2249	SV049	PGN1sp	Spindle position loop gain 1	Set the position loop gain for special operations (synchronous tap, interpolation with spindle C axis, etc.). Normally, set the spindle position loop gain.	1 to 200 (1/s)
2250	SV050	PGN2sp	Spindle position loop gain 2	Set this with SV058 (SHGCsp) when carrying out SHG control during special operations (synchronous tap, interpolation with spindle C axis, etc.). When this parameter is not used, set "0".	0 to 999 (1/s)
2251	SV051	DFBT	Dual control time constant	Set the compensation time constant for dual feedback control.	0 to 9999 (ms)
2252	SV052	DFBN	Dual control dead zone width	Set the dead zone amount for dual feedback control.	0 to 9999 (μm)
2253	SV053	OD3	Excessive error width 3	Set the excessive error detection width at servo ON for special operations (absolute position initialization setting, stopper operation, etc.). When "0" is set, the excessive error will not be detected at servo ON during special operations.	0 to 32767 (mm)
2254	SV054	ORE	Closed loop overrun detection width	Set the overrun detection width for the closed loop. When "-1" is set, the overrun will not be detected. When "0" is set, the overrun will be detected with a 2 (mm) width.	-1 to 32767 (mm)
			Position tracking speed during changeover from torque constant control to position loop	<b>For intelligent servo</b> Set the speed for returning to the command position during changingover from torque constant control to position loop control. Set the return amount for 444μs as an interpolation unit.	0 to 32767 (Interpolation unit)
2255	SV055	EMGx	Drop prevention emergency stop maximum delay time	Set the emergency stop maximum delay time when using the drop prevention function. Normally, set it to the same value as the SV056 (EMGt). Set to "0" when not using the drop prevention function.	0 to 2000 (ms)
2256	SV056	EMGt	Drop prevention deceleration time constant	Set the deceleration time constant from the maximum rapid traverse speed when using the drop prevention function. Normally, set it to the same value as the CNC G0 acceleration/deceleration time constant. Set to "0" when not using the drop prevention function.	0 to 2000 (ms) For MDS-B-SVJ2: 0 to 5000 (ms)
2257	SV057 SHGC		High gain control constant	Set this with SV050 (PGN2sp), SV003 (PGN1) and SV004 (PGN2) when carrying out SGH control. Set to "0" when not using this function.	0 to 999 (1/s)

**4.7 Servo Parameters**  
**4.7.1 Servo Parameters**

No.	Item		Details	Setting range (unit)	
2258	SV058	SHGC <sub>sp</sub>	Spindle synchronous time high gain constant	Set this with SV050 (PGN2sp) when carrying out SHG control during special operations (synchronous tap, interpolation with spindle C axis, etc.). Set to "0" when not using this function.	0 to 999 (1/s)
2259	SV059	TCNV	Torque estimated gain	When using the collision detection function, set the estimated torque gain. When "1" is set in SV035: SSF4/clt, the setting value guideline can be displayed in MPOF on the Servo monitor screen. Set to "0" when not using the collision detection function.	0 to 32767
2260	SV060	TLMT	G0 collision detection level	When using the collision detection function, set the collision detection level for the method 1-G0 modal with a rate for the stall rated current. Set to "0" when not using the collision detection function.	0 to 100 (Stall rated current %)
2261	SV061	DA1NO	D/A output channel-1 data number	Set the output data number for channel 1 of the D/A output function. When "-1" is set, the D/A output of that axis will not be carried out.  If this parameter is set to "0" when using the intelligent servo, SV063 will function as the offset amount.	0 to 32767 0 to 102 for MDS-B-SVJ2 and intelligent servo
2262	SV062	DA2NO	D/A output channel-2 data number	Set the output data number for channel 2 of the D/A output function. When "-1" is set, the D/A output of that axis will not be carried out.	0 to 32767 0 to 102 for MDS-B-SVJ2 and intelligent servo
2263	SV063	DA1MPY	D/A output channel-1 magnification	Set the output data magnification for channel 1 of the D/A output function. The output magnification will be the setting value/256. If "0" is set, the output magnification will be 1-fold, in the same manner as when "256" is set.	-32768 to 32767
2264	SV064	DA2MPY	D/A output channel-2 magnification	Set the output data magnification for channel 2 of the D/A output function. The output magnification will be the setting value/256. If "0" is set, the output magnification will be 1-fold, in the same manner as when "256" is set.	-32768 to 32767
	SV065 to SV080			Not used.	

**4.7 Servo Parameters**  
**4.7.2 Supplementary Explanation (MDS-B-V1/V2)**

---

**4.7.2 Supplementary Explanation (MDS-B-V1/V2)**

**(1) Command polarity**

When the motor rotates in the clockwise direction (looking from the load side) at the command for the + direction, the command direction is CW. Conversely, when the motor rotates in the counterclockwise direction, the command direction is CCW.

This rotation direction can be set with the NC machine parameters. Note that the meaning of the ± direction will be reversed for some servo parameters according to the motor rotation direction. The servo parameters affected by CW/CCW are shown below.

SV016 (LMC1), SV041 (LMC2)                   (When different values are set for SV016 and SV041)  
 SV031 (OVS1), SV042 (OVS2)               (When different values are set for SV031 and SV042)

**<Example>** If the lost motion compensation amount is to be changed according to the direction, the compensation amount at the quadrant changeover point of each arc where the lost motion compensation is applied will be as shown below according to the command polarity.

	CW	CCW
A	X: SV041	X: SV016
B	Y: SV016	Y: SV041
C	X: SV016	X: SV041
D	Y: SV041	Y: SV016

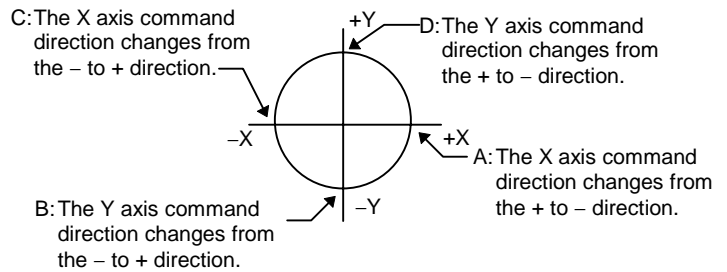

**4.7 Servo Parameters**  
**4.7.2 Supplementary Explanation (MDS-B-V1/V2)**

---

**(2) Electronic gears**

By setting the ball screw lead, deceleration ratio (or acceleration ratio), and detector resolution correctly with parameters, the command movement amount and machine end movement amount can be matched.

The following parameters are related to these electronic gears, and directly affect the machine operation.

Take care to set these correctly.

**(a) Parameters related to electronic gears**

SV001 (PC1), SV002 (PC2), SV003 (PGN1), SV018 (PIT), SV019 (RNG1), SV020 (RNG2)

**(b) PC1 and PC2 setting range**

As a principle, the setting range of SV001 (PC1) and SV002 (PC2) is 1 to 30. However, if the following conditions are satisfied, a value higher than 30 can be set. Note that the following conditions must be satisfied even when setting a value between 1 and 30.

For semi-closed loop :  $PC1' < 32767 / PIT' / IUNIT$ ,  $PC2' < 32767 / RNG1'$

For closed loop :  $PC1' < 32767 / RNG1C / 30$ ,  $PC2' < 32767 / RNG2C / PGN1$

**Meaning of symbols**

PC1' Value obtained by dividing PC1 and PC2 with greatest common divisor  
 PC2' Value obtained by dividing PC2 and PC1 with greatest common divisor  
 PIT' Value obtained by dividing PIT and RNG1 with greatest common divisor  
 RNG1' Value obtained by dividing RNG1 and PIT with greatest common divisor  
 RNG1C Value obtained by dividing RNG1 and RNG2 with greatest common divisor  
 RNG2C Value obtained by dividing RNG2 and RNG1 with greatest common divisor  
 IUNIT NC interpolation unit

NC interpolation unit	IUNIT
0.500μm	2
0.050μm	20
0.005μm	200

**(c) Example of calculating PC1 and PC2 setting range**

To use a ball screw lead of 10mm, interpolation unit of 0.5μm and OHE25K or OHA25K motor end detector with semi-closed loop

The following parameters are determined by the above conditions.

SV018 (PIT) = 10, SV019 (RNG1) = 100, SV020 (RNG2) = 100, IUNIT = 2

Obtain PIT' and RNG1'.

PIT' = 1, RNG1' = 10 (Greatest common divisor = 10)

Obtain the maximum value of PC1 and PC2 with the calculation expression for the semi-closed loop.

$PC1' < 32767 / 1 / 2 < 16383$   
 $PC2' < 32767 / 10 < 3276$

With the above calculations, the setting range for PC1 is 1 to 16383 and for PC2 is 1 to 3276.

**4.7 Servo Parameters**  
**4.7.2 Supplementary Explanation (MDS-B-V1/V2)**

---

**(3) Current limit value**

Motor	Stall rated current Arm	Maximum current Arm	Maximum torque kg-cm	%
HA40N	3.6	17	145	472
HA80N	6.6	28	260	424
HA100N	14	42	428	300
HA200N	22	57	610	260
HA300N	37	85	893	230
HA700N	49	113	1220	231
HA900N	56	141	1565	252
HA053	1.4	3.9	7	279
HA13	1.4	3.9	14	279
HA23N	3	8.1	28	270
HA33N	3	8.1	57	270
HA43N	5	17	104	340
HA83N	8.8	28	196	318
HA103N	19.6	57	410	291
HA203N	34.5	85	570	246
HA303N	55	113	814	205
HA703N	68	141	1072	207
HA50L	4	17	133	425
HA100L	8	28	213	350
HA150L	11.5	42	320	365
HA200L	18.2	42	323	231
HA300L	25	57	530	228
HA500L	44	87	740	193
HC52	3.9	17	120	436
HC102	7.4	28	220	378
HC152	11.1	47	360	423
HC202	15.4	47	425	305
HC352	22.9	64	610	279
HC53	5.8	17	90	293
HC103	9.8	28	170	286
HC153	15.9	47	290	296
HC203	22.4	64	410	286
HC353	33.3	85	570	255
HC453	57.3	113	814	197

**(Note)** When set "500%" for SV013 ILMT1, the current limit value is maximum current (torque) one shown the above table.  
Set this parameter at the rate (%) of the stall rated current, when the current limit value is selected one under maximum current (torque).

## 4.7 Servo Parameters

### 4.7.3 Intelligent Servo D/A Output Function

#### 4.7.3 Intelligent Servo D/A Output Function

##### <Outline>

This function, which D/A outputs various control data, is built into the intelligent servomotor amplifier section.

##### <Output specifications>

- No. of channels : 1 channel
- Output cycle : 888 $\mu$ s (minimum value)
- Output precision : 8 bit
- Output voltage : 0V to 2.5V to 5V
- Output pin :
- Magnification setting :  $\pm 1/256$  to  $\pm 128$ -fold

##### <Output function>

- Offset amount adjusting function
- Output clamp function
- Low pass filter function

##### <Output data No.>

Set the required output data No. in SV061.

No.	Output data	Standard output	Output cycle
0	0V test output	For offset adjustment	
1	Speed feedback	2000 (r/min)/1V	888 $\mu$ s
2	Current feedback	Rated (stall) current/0.5V	888 $\mu$ s
3	Speed command	2000 (r/min)/1V	888 $\mu$ s
4	Current command	Rated (stall) current/0.5V	
5	V phase current value	40A/V	888 $\mu$ s
6	W phase current value	40A/V	888 $\mu$ s
7	Estimated disturbance torque	Rated (stall) current/0.5V	888 $\mu$ s
8	–		
9	–		
10	–		
11	Position droop	4mm/V	3.55ms
12	Position droop (×10)	400 $\mu$ mm/V	3.55ms
13	Position droop (×100)	40 $\mu$ mm/V	3.55ms
14	Feedrate (F $\Delta$ T)	40000 (mm/min)/V	888 $\mu$ s
15	Feedrate (F $\Delta$ T×10)	4000 (mm/min)/V	888 $\mu$ s
16	–		
17	–		
18	–		
19	q axis current integral value		888 $\mu$ s
20	d axis current integral value		888 $\mu$ s

No.	Output data	Standard output	Output cycle
21	Motor load level	100%/1.25V	113.7ms
22	Amplifier load level	100%/1.25V	113.7ms
23	Regeneration load level	100%/1.25V	910.2ms
24	PN bus voltage	200V/V (1/200)	888 $\mu$ s
25	Speed integral item	–	888 $\mu$ s
26	Cycle counter	2.5V to 3.75V (resolution unrelated)	888 $\mu$ s
27	–		
28	–		
29	–		
30	–		
31 to 99	–		
100	5V test output	–	–
101	Test output sawtooth wave	1.25 to 3.75V Cycle 113.7ms	888 $\mu$ s
102	Rectangular wave test output	2.5 to 3.75V Cycle 227.5ms	888 $\mu$ s
103 to	Setting prohibited		

## 4.7 Servo Parameters

### 4.7.3 Intelligent Servo D/A Output Function

#### <Setting the output magnification>

Set the output magnification in SV063. Set when output in other than the standard output units is required.

**(Example 1)** When SV061 = 5, SV063 = 2560:  
V phase current values are output in 4 A/V units to D/A output channel 1.

Item	Abbreviation	Name	Details	Setting range
SV061	DA1NO	D/A output channel-1 data number	Set the output data number for channel 1 of the D/A output function. When "-1" is set, the D/A output of that axis will not be carried out.  If this parameter is set to "0" when using the intelligent servo, SV063 will function as the offset amount.	0 to 32767 0 to 102 for MDS-B-SVJ2 and intelligent servo
SV063	DA1MPY	D/A output channel-1 output magnification	Set the output data magnification for channel 1 of the D/A output function. The output magnification will be the setting value/256. If "0" is set, the output magnification will be 1-fold, in the same manner as when "256" is set.	-32768 to 32767

#### <Setting the offset amount>

Used when fine tuning of the output voltage zero level is required. The output magnification when the data No. is "0" will become the offset amount. After setting the offset, set the data No. to a value other than "0", and do not let the value become "0" again.

When the amplifier power is turned OFF, the offset value will be reset. (The value will not be reset when the NC power is turned OFF.)

Item	Abbreviation	Name	Details	Setting range
SV061	DA1NO	D/A output channel-1 data number	Set to "0".	-32768 to 32767
SV063	DA1MPY	D/A output channel-1 offset amount	Setting can be made in output precision units. While observing the output value, set so that the output value becomes 0V.	-10 to 10

#### <Clamp function>

Used when the output values of position droop, etc., exceed the output range and overflow.

Position droop

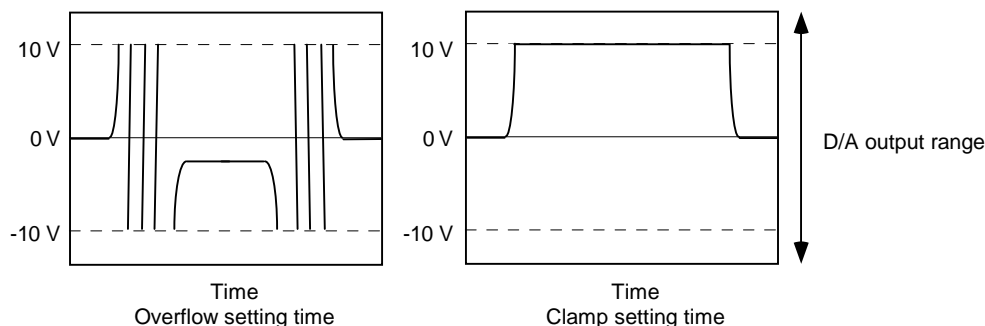

**4.7 Servo Parameters**  
**4.7.3 Intelligent Servo D/A Output Function**

---

**<Filter function>**

The cutoff frequency 140Hz low pass filter can be set.

Item	Abbreviation	Name	Details																																																																												
SV034	SSF3	Special servo function 3	<p>Select the special servo functions.</p> <table style="width: 100%; text-align: center; border-collapse: collapse;"> <tr> <td style="border: none;">F</td><td style="border: none;">E</td><td style="border: none;">D</td><td style="border: none;">C</td><td style="border: none;">B</td><td style="border: none;">A</td><td style="border: none;">9</td><td style="border: none;">8</td> </tr> <tr> <td style="border: 1px solid black; width: 25px; height: 20px;"></td> <td style="border: 1px solid black; width: 25px; height: 20px;"></td> <td style="border: 1px solid black; width: 25px; height: 20px;"></td> <td style="border: 1px solid black; width: 25px; height: 20px;"></td> <td style="border: 1px solid black; width: 25px; height: 20px;"></td> <td style="border: 1px solid black; width: 25px; height: 20px;"></td> <td style="border: 1px solid black; width: 25px; height: 20px;"></td> <td style="border: 1px solid black; width: 25px; height: 20px;"></td> </tr> <tr> <td style="border: none;">7</td><td style="border: none;">6</td><td style="border: none;">5</td><td style="border: none;">4</td><td style="border: none;">3</td><td style="border: none;">2</td><td style="border: none;">1</td><td style="border: none;">0</td> </tr> <tr> <td style="border: 1px solid black; width: 25px; height: 20px;"></td> <td style="border: 1px solid black; width: 25px; height: 20px;">daf1</td> <td style="border: 1px solid black; width: 25px; height: 20px;"></td> <td style="border: 1px solid black; width: 25px; height: 20px;">dac1</td> <td style="border: 1px solid black; width: 25px; height: 20px;"></td> <td style="border: 1px solid black; width: 25px; height: 20px;"></td> <td style="border: 1px solid black; width: 25px; height: 20px;"></td> <td style="border: 1px solid black; width: 25px; height: 20px;">mon</td> </tr> </table> <table border="1" style="width: 100%; border-collapse: collapse;"> <thead> <tr> <th style="width: 5%;">bit</th> <th style="width: 10%;">Name</th> <th style="width: 35%;">Meaning when set to 0</th> <th style="width: 50%;">Meaning when set to 1</th> </tr> </thead> <tbody> <tr> <td style="text-align: center;">0</td> <td style="text-align: center;">mon</td> <td>Current command monitor display</td> <td>Current FB monitor display</td> </tr> <tr> <td style="text-align: center;">1</td> <td></td> <td></td> <td></td> </tr> <tr> <td style="text-align: center;">2</td> <td></td> <td></td> <td></td> </tr> <tr> <td style="text-align: center;">3</td> <td></td> <td></td> <td></td> </tr> <tr> <td style="text-align: center;">4</td> <td style="text-align: center;">dac1</td> <td>D/A output ch.1 overflow setting</td> <td>D/A output ch.1 clamp setting</td> </tr> <tr> <td style="text-align: center;">5</td> <td></td> <td></td> <td></td> </tr> <tr> <td style="text-align: center;">6</td> <td style="text-align: center;">daf1</td> <td>D/A output ch.1 no filter</td> <td>D/A output ch.1 filter setting</td> </tr> <tr> <td style="text-align: center;">7</td> <td></td> <td></td> <td></td> </tr> <tr> <td style="text-align: center;">:</td> <td></td> <td style="text-align: center;">:</td> <td style="text-align: center;">:</td> </tr> <tr> <td style="text-align: center;">F</td> <td></td> <td></td> <td></td> </tr> </tbody> </table> <p><b>(Note)</b> Set "0" in bits with no particular description.</p>	F	E	D	C	B	A	9	8									7	6	5	4	3	2	1	0		daf1		dac1				mon	bit	Name	Meaning when set to 0	Meaning when set to 1	0	mon	Current command monitor display	Current FB monitor display	1				2				3				4	dac1	D/A output ch.1 overflow setting	D/A output ch.1 clamp setting	5				6	daf1	D/A output ch.1 no filter	D/A output ch.1 filter setting	7				:		:	:	F			
F	E	D	C	B	A	9	8																																																																								
7	6	5	4	3	2	1	0																																																																								
	daf1		dac1				mon																																																																								
bit	Name	Meaning when set to 0	Meaning when set to 1																																																																												
0	mon	Current command monitor display	Current FB monitor display																																																																												
1																																																																															
2																																																																															
3																																																																															
4	dac1	D/A output ch.1 overflow setting	D/A output ch.1 clamp setting																																																																												
5																																																																															
6	daf1	D/A output ch.1 no filter	D/A output ch.1 filter setting																																																																												
7																																																																															
:		:	:																																																																												
F																																																																															



**4.7 Servo Parameters**  
**4.7.4 Standard Parameters Setting**

---

**4.7.4 Standard Parameters Setting (MDS-B-V1/V2, intelligent servo)**

**(1) Standard Parameters for Each Motor**

**(a) 2000 r/min motor**

Parameter	HA40N	HA80N	HA100N	HA200N	HA300N	HA700N	HA900N			
SV001	PC1									
SV002	PC2									
SV003	PGN1	33	33	33	33	33	25	25		
SV004	PGN2	0	0	0	0	0	0	0		
SV005	VGN1	150	150	150	150	150	250	250		
SV006	VGN2	0	0	0	0	0	0	0		
SV007	VIL	0	0	0	0	0	0	0		
SV008	VIA	1364	1364	1364	1364	1364	1364	1364		
SV009	IQA	2048	2048	1024	1024	1024	1024	1024		
SV010	IDA	2048	2048	2048	2048	2048	2048	2048		
SV011	IQG	512	512	256	256	256	200	200		
SV012	IDG	512	512	512	512	512	256	256		
SV013	ILMT	500	500	500	500	500	500	500		
SV014	ILMTsp	500	500	500	500	500	500	500		
SV015	FFC	0	0	0	0	0	0	0		
SV016	LMC1	0	0	0	0	0	0	0		
SV017	SPEC	0000	0000	0000	0000	0000	0000	0000		
SV018	PIT	-	-	-	-	-	-	-		
SV019	RNG1	-	-	-	-	-	-	-		
SV020	RNG2	-	-	-	-	-	-	-		
SV021	OLT	60	60	60	60	60	60	60		
SV022	OLL	150	150	150	150	150	150	150		
SV023	OD1	6	6	6	6	6	6	6		
SV024	INP	50	50	50	50	50	50	50		
SV025	MTYP	xx00	xx01	xx02	xx03	xx04	xx05	xx06		
SV026	OD2	6	6	6	6	6	6	6		
SV027	SSF1	0	0	0	0	0	0	0		
SV028		0	0	0	0	0	0	0		
SV029	VCS	0	0	0	0	0	0	0		
SV030	IVC	0	0	0	0	0	0	0		
SV031	OVS1	0	0	0	0	0	0	0		
SV032	TOF	0	0	0	0	0	0	0		
SV033	SSF2	0000	0000	0000	0000	0000	0000	0000		
SV034	SSF3	0000	0000	0000	0000	0000	0000	0000		
SV035	SSF4	0000	0000	0000	0000	0000	0000	0000		
SV036	PTYP	0000	0000	0000	0000	0000	0000	0000		
SV037	JL	0	0	0	0	0	0	0		
SV038	FHz	0	0	0	0	0	0	0		
SV039	LMCD	0	0	0	0	0	0	0		

**4.7 Servo Parameters**  
**4.7.4 Standard Parameters Setting**

---

Parameter		HA40N	HA80N	HA100N	HA200N	HA300N	HA700N	HA900N			
SV040	LMCT	0	0	0	0	0	0	0			
SV041	LMC2	0	0	0	0	0	0	0			
SV042	OVS2	0	0	0	0	0	0	0			
SV043	OBS1	0	0	0	0	0	0	0			
SV044	OBS2	0	0	0	0	0	0	0			
SV045	TRUB	0	0	0	0	0	0	0			
SV046		0	0	0	0	0	0	0			
SV047	EC1	100	100	100	100	100	100	100			
SV048	EMGrt	0	0	0	0	0	0	0			
SV049	PGN1SP	15	15	15	15	15	15	15			
SV050	PGN2SP	0	0	0	0	0	0	0			
SV051	DFBT	0	0	0	0	0	0	0			
SV052	DFBN	0	0	0	0	0	0	0			
SV053	OD3	0	0	0	0	0	0	0			
SV054	ORE	0	0	0	0	0	0	0			
SV055	EMGx	0	0	0	0	0	0	0			
SV056	EMGt	0	0	0	0	0	0	0			
SV057	SHGC	0	0	0	0	0	0	0			
SV058	SHGCSP	0	0	0	0	0	0	0			
SV059	TCNV	0	0	0	0	0	0	0			
SV060	TLMT	0	0	0	0	0	0	0			
SV061	DA1NO	0	0	0	0	0	0	0			
SV062	DA2NO	0	0	0	0	0	0	0			
SV063	DA1MPY	0	0	0	0	0	0	0			
SV064	DA2MPY	0	0	0	0	0	0	0			

**4.7 Servo Parameters**  
**4.7.4 Standard Parameters Setting**

---

**(b) 2000 r/min low-inertia motor**

Parameter		HA50L	HA100L	HA150L	HA200L	HA300L	HA500L	HA-A11KL	HA-A15KL
SV001	PC1	–	–	–	–	–	–	–	–
SV002	PC2	–	–	–	–	–	–	–	–
SV003	PGN1	33	33	33	33	33	33	33	33
SV004	PGN2	0	0	0	0	0	0	0	0
SV005	VGN1	30	30	30	30	30	50	150	150
SV006	VGN2	0	0	0	0	0	0	0	0
SV007	VIL	0	0	0	0	0	0	0	0
SV008	VIA	1364	1364	1364	1364	1364	1364	1364	1364
SV009	IQA	2048	2048	2048	2048	2048	2048	2048	2048
SV010	IDA	2048	2048	2048	2048	2048	2048	2048	2048
SV011	IQG	512	512	512	512	256	256	512	512
SV012	IDG	512	512	512	512	512	512	512	512
SV013	ILMT	500	500	500	500	500	500	500	500
SV014	ILMTsp	500	500	500	500	500	500	500	500
SV015	FFC	0	0	0	0	0	0	0	0
SV016	LMC1	0	0	0	0	0	0	0	0
SV017	SPEC	0000	0000	0000	0000	0000	0000	0000	0000
SV018	PIT	–	–	–	–	–	–	–	–
SV019	RNG1	–	–	–	–	–	–	–	–
SV020	RNG2	–	–	–	–	–	–	–	–
SV021	OLT	60	60	60	60	60	60	60	3
SV022	OLL	150	150	150	150	150	150	150	150
SV023	OD1	6	6	6	6	6	6	6	6
SV024	INP	50	50	50	50	50	50	50	50
SV025	MTYP	xx20	xx21	xx2A	xx22	xx23	xx24	xx27	xx28
SV026	OD2	6	6	6	6	6	6	6	6
SV027	SSF1	4000	4000	4000	4000	4000	4000	4000	4000
SV028		0	0	0	0	0	0	0	0
SV029	VCS	0	0	0	0	0	0	0	0
SV030		0	0	0	0	0	0	0	0
SV031	OVS1	0	0	0	0	0	0	0	0
SV032	TOF	0	0	0	0	0	0	0	0
SV033	SSF2	0000	0000	0000	0000	0000	0000	0000	0000
SV034	SSF3	0000	0000	0000	0000	0000	0000	0000	0000
SV035	SSF4	0000	0000	0000	0000	0000	0000	0000	0000
SV036	PTYP	0000	0000	0000	0000	0000	0000	0000	0000
SV037	JL	0	0	0	0	0	0	0	0
SV038	FHz	0	0	0	0	0	0	0	0
SV039	LMCD	0	0	0	0	0	0	0	0

**4.7 Servo Parameters**  
**4.7.4 Standard Parameters Setting**

---

Parameter		HA50L	HA100L	HA150L	HA200L	HA300L	HA500L	HA-A11KL	HA-A15KL
SV040	LMCT	0	0	0	0	0	0	0	0
SV041	LMC2	0	0	0	0	0	0	0	0
SV042	OVS2	0	0	0	0	0	0	0	0
SV043	OBS1	0	0	0	0	0	0	0	0
SV044	OBS2	0	0	0	0	0	0	0	0
SV045	TRUB	0	0	0	0	0	0	0	0
SV046		0	0	0	0	0	0	0	0
SV047	EC1	100	100	100	100	100	100	100	100
SV048	EMGrt	0	0	0	0	0	0	0	0
SV049	PGN1sp	15	15	15	15	15	15	15	15
SV050	PGN2sp	0	0	0	0	0	0	0	0
SV051	DFBT	0	0	0	0	0	0	0	0
SV052	DFBN	0	0	0	0	0	0	0	0
SV053	OD3	0	0	0	0	0	0	0	0
SV054	ORE	0	0	0	0	0	0	0	0
SV055	EMGx	0	0	0	0	0	0	0	0
SV056	EMGt	0	0	0	0	0	0	0	0
SV057	SHGC	0	0	0	0	0	0	0	0
SV058	SHGCsp	0	0	0	0	0	0	0	0
SV059	TCNV	0	0	0	0	0	0	0	0
SV060	TLMT	0	0	0	0	0	0	0	0
SV061	DA1NO	0	0	0	0	0	0	0	0
SV062	DA2NO	0	0	0	0	0	0	0	0
SV063	DA1MPY	0	0	0	0	0	0	0	0
SV064	DA2MPY	0	0	0	0	0	0	0	0

**4.7 Servo Parameters**  
**4.7.4 Standard Parameters Setting**

---

**(c) 3000 r/min low-inertia motor**

Parameter	HA53L	HA103L	HA153L	HA203L	HA303L	HA503L			
SV001	PC1								
SV002	PC2								
SV003	PGN1	33	33	33	33	33	33		
SV004	PGN2	0	0	0	0	0	0		
SV005	VGN1	30	30	30	30	30	50		
SV006	VGN2	0	0	0	0	0	0		
SV007	VIL	0	0	0	0	0	0		
SV008	VIA	1364	1364	1364	1364	1364	1364		
SV009	IQA	2048	2048	2048	2048	2048	2048		
SV010	IDA	2048	2048	2048	2048	2048	2048		
SV011	IQG	512	512	512	512	256	256		
SV012	IDG	512	512	512	512	512	512		
SV013	ILMT	500	500	500	500	500	500		
SV014	ILMTsp	500	500	500	500	500	500		
SV015	FFC	0	0	0	0	0	0		
SV016	LMC1	0	0	0	0	0	0		
SV017	SPEC	0000	0000	0000	0000	0000	0000		
SV018	PIT	-	-	-	-	-	-		
SV019	RNG1	-	-	-	-	-	-		
SV020	RNG2	-	-	-	-	-	-		
SV021	OLT	60	60	60	60	60	60		
SV022	OLL	150	150	150	150	150	150		
SV023	OD1	6	6	6	6	6	6		
SV024	INP	50	50	50	50	50	50		
SV025	MTYP	xx30	xx31	xx3A	xx32	xx33	xx34		
SV026	OD2	6	6	6	6	6	6		
SV027	SSF1	4000	4000	4000	4000	4000	4000		
SV028		0	0	0	0	0	0		
SV029	VCS	0	0	0	0	0	0		
SV030	IVC	0	0	0	0	0	0		
SV031	OVS1	0	0	0	0	0	0		
SV032	TOF	0	0	0	0	0	0		
SV033	SSF2	0000	0000	0000	0000	0000	0000		
SV034	SSF3	0000	0000	0000	0000	0000	0000		
SV035	SSF4	0000	0000	0000	0000	0000	0000		
SV036	PTYP	0000	0000	0000	0000	0000	0000		
SV037	JL	0	0	0	0	0	0		
SV038	FHz	0	0	0	0	0	0		
SV039	LMCD	0	0	0	0	0	0		

**4.7 Servo Parameters**  
**4.7.4 Standard Parameters Setting**

---

Parameter		HA53L	HA103L	HA153L	HA203L	HA303L	HA503L			
SV040	LMCT	0	0	0	0	0	0			
SV041	LMC2	0	0	0	0	0	0			
SV042	OVS2	0	0	0	0	0	0			
SV043	OBS1	0	0	0	0	0	0			
SV044	OBS2	0	0	0	0	0	0			
SV045	TRUB	0	0	0	0	0	0			
SV046		0	0	0	0	0	0			
SV047	EC1	100	100	100	100	100	100			
SV048	EMGrt	0	0	0	0	0	0			
SV049	PGN1sp	15	15	15	15	15	15			
SV050	PGN2sp	0	0	0	0	0	0			
SV051	DFBT	0	0	0	0	0	0			
SV052	DFBN	0	0	0	0	0	0			
SV053	OD3	0	0	0	0	0	0			
SV054	ORE	0	0	0	0	0	0			
SV055	EMGx	0	0	0	0	0	0			
SV056	EMGt	0	0	0	0	0	0			
SV057	SHGC	0	0	0	0	0	0			
SV058	SHGCsp	0	0	0	0	0	0			
SV059	TCNV	0	0	0	0	0	0			
SV060	TLMT	0	0	0	0	0	0			
SV061	DA1NO	0	0	0	0	0	0			
SV062	DA2NO	0	0	0	0	0	0			
SV063	DA1MPY	0	0	0	0	0	0			
SV064	DA2MPY	0	0	0	0	0	0			

**4.7 Servo Parameters**  
**4.7.4 Standard Parameters Setting**

**(d) 3000 r/min motor**

Parameter	HA43N	HA83N	HA93N	HA103N	HA203N	HA303N	HA703N	HA53	HA13	HA23N	HA33N
SV001	PC1	–	–	–	–	–	–	–	–	–	–
SV002	PC2	–	–	–	–	–	–	–	–	–	–
SV003	PGN1	33	33	33	33	33	33	25	33	33	33
SV004	PGN2	0	0	0	0	0	0	0	0	0	0
SV005	VGN1	150	150	150	150	150	150	250	70	70	100
SV006	VGN2	0	0	0	0	0	0	0	0	0	0
SV007	VIL	0	0	0	0	0	0	0	0	0	0
SV008	VIA	1364	1364	1364	1364	1364	1364	1364	1364	1364	1364
SV009	IQA	2048	2048	2048	2048	2048	2048	2048	2048	2048	2048
SV010	IDA	2048	2048	2048	2048	2048	2048	2048	2048	2048	2048
SV011	IQG	256	256	256	256	256	256	200	256	256	224
SV012	IDG	512	512	512	512	512	512	256	256	256	224
SV013	ILMT	500	500	500	500	500	500	500	500	500	500
SV014	ILMTsp	500	500	500	500	500	500	500	500	500	500
SV015	FFC	0	0	0	0	0	0	0	0	0	0
SV016	LMC1	0	0	0	0	0	0	0	0	0	0
SV017	SPEC	0000	0000	0000	0000	0000	0000	0000	0000	0000	0000
SV018	PIT	–	–	–	–	–	–	–	–	–	–
SV019	RNG1	–	–	–	–	–	–	10	10	–	–
SV020	RNG2	–	–	–	–	–	–	10	10	–	–
SV021	OLT	60	60	60	60	60	60	60	60	60	60
SV022	OLL	150	150	150	150	150	150	150	150	150	150
SV023	OD1	6	6	6	6	6	6	6	6	6	6
SV024	INP	50	50	50	50	50	50	50	50	50	50
SV025	MTYP	xx80	xx81	xx8A	xx82	xx83	xx84	xx85	338C	338D	xx8E
SV026	OD2	6	6	6	6	6	6	6	6	6	6
SV027	SSF1	4000	4000	4000	4000	4000	4000	4000	4000	4000	4000
SV028		0	0	0	0	0	0	0	0	0	0
SV029	VCS	0	0	0	0	0	0	0	0	0	0
SV030	IVC	0	0	0	0	0	0	0	0	0	0
SV031	OVS1	0	0	0	0	0	0	0	0	0	0
SV032	TOF	0	0	0	0	0	0	0	0	0	0
SV033	SSF2	000	000	000	0000	0000	0000	0000	000	000	000
SV034	SSF3	000	000	000	0000	0000	0000	0000	000	000	000
SV035	SSF4	000	000	000	0000	0000	0000	0000	000	000	000
SV036	PTYP	000	000	000	0000	0000	0000	0000	000	000	000
SV037	JL	0	0	0	0	0	0	0	0	0	0
SV038	FHz	0	0	0	0	0	0	0	0	0	0
SV039	LMCD	0	0	0	0	0	0	0	0	0	0

**4.7 Servo Parameters**  
**4.7.4 Standard Parameters Setting**

---

Parameter		HA43N	HA83N	HA93N	HA103N	HA203N	HA303N	HA703N	HA53	HA13	HA23N	HA33N
SV040	LMCT	0	0	0	0	0	0	0	0	0	0	0
SV041	LMC2	0	0	0	0	0	0	0	0	0	0	0
SV042	OVS2	0	0	0	0	0	0	0	0	0	0	0
SV043	OBS1	0	0	0	0	0	0	0	0	0	0	0
SV044	OBS2	0	0	0	0	0	0	0	0	0	0	0
SV045	TRUB	0	0	0	0	0	0	0	0	0	0	0
SV046		0	0	0	0	0	0	0	0	0	0	0
SV047	EC1	100	100	100	100	100	100	100	100	100	100	100
SV048	EMGrt	0	0	0	0	0	0	0	0	0	0	0
SV049	PGN1sp	15	15	15	15	15	15	15	15	15	15	15
SV050	PGN2sp	0	0	0	0	0	0	0	0	0	0	0
SV051	DFBT	0	0	0	0	0	0	0	0	0	0	0
SV052	DFBN	0	0	0	0	0	0	0	0	0	0	0
SV053	OD3	0	0	0	0	0	0	0	0	0	0	0
SV054	ORE	0	0	0	0	0	0	0	0	0	0	0
SV055	EMGx	0	0	0	0	0	0	0	0	0	0	0
SV056	EMGt	0	0	0	0	0	0	0	0	0	0	0
SV057	SHGC	0	0	0	0	0	0	0	0	0	0	0
SV058	SHGCsp	0	0	0	0	0	0	0	0	0	0	0
SV059	TCNV	0	0	0	0	0	0	0	0	0	0	0
SV060	TLMT	0	0	0	0	0	0	0	0	0	0	0
SV061	DA1NO	0	0	0	0	0	0	0	0	0	0	0
SV062	DA2NO	0	0	0	0	0	0	0	0	0	0	0
SV063	DA1MPY	0	0	0	0	0	0	0	0	0	0	0
SV064	DA2MPY	0	0	0	0	0	0	0	0	0	0	0



**4.7 Servo Parameters**  
**4.7.4 Standard Parameters Setting**

---

**(e) 2000 r/min medium-inertia motor**

Parameter	HC52	HC102	HC152	HC202	HC352	HC452	HC702	HC902	
SV001	PC1	–	–	–	–	–	–	–	–
SV002	PC2	–	–	–	–	–	–	–	–
SV003	PGN1	33	33	33	33	33	33	33	33
SV004	PGN2	0	0	0	0	0	0	0	0
SV005	VGN1	100	100	100	100	100	100	150	150
SV006	VGN2	0	0	0	0	0	0	0	0
SV007	VIL	0	0	0	0	0	0	0	0
SV008	VIA	1364	1364	1364	1364	1364	1364	1364	1364
SV009	IQA	2048	2048	2048	2048	2048	2048	2048	2048
SV010	IDA	2048	2048	2048	2048	2048	2048	2048	2048
SV011	IQG	512	512	512	256	256	256	200	200
SV012	IDG	512	512	512	512	512	512	256	256
SV013	ILMT	500	500	500	500	500	500	500	500
SV014	ILMTsp	500	500	500	500	500	500	500	500
SV015	FFC	0	0	0	0	0	0	0	0
SV016	LMC1	0	0	0	0	0	0	0	0
SV017	SPEC	0000	0000	0000	0000	0000	0000	0000	0000
SV018	PIT	–	–	–	–	–	–	–	–
SV019	RNG1	–	–	–	–	–	–	–	–
SV020	RNG2	–	–	–	–	–	–	–	–
SV021	OLT	60	60	60	60	60	60	60	60
SV022	OLL	150	150	150	150	150	150	150	150
SV023	OD1	6	6	6	6	6	6	6	6
SV024	INP	50	50	50	50	50	50	50	50
SV025	MTYP	xxB0	xxB1	xxB2	xxB3	xxB4	xxB5	xxB6	xxB7
SV026	OD2	6	6	6	6	6	6	6	6
SV027	SSF1	4000	4000	4000	4000	4000	4000	4000	4000
SV028		0	0	0	0	0	0	0	0
SV029	VCS	0	0	0	0	0	0	0	0
SV030	IVC	0	0	0	0	0	0	0	0
SV031	OVS1	0	0	0	0	0	0	0	0
SV032	TOF	0	0	0	0	0	0	0	0
SV033	SSF2	0000	0000	0000	0000	0000	0000	0000	0000
SV034	SSF3	0003	0003	0003	0003	0003	0003	0003	0003
SV035	SSF4	0000	0000	0040	0040	0040	0040	0040	0040
SV036	PTYP	0000	0000	0000	0000	0000	0000	0000	0000
SV037	JL	0	0	0	0	0	0	0	0
SV038	FHz	0	0	0	0	0	0	0	0
SV039	LMCD	0	0	0	0	0	0	0	0

**4.7 Servo Parameters**  
**4.7.4 Standard Parameters Setting**

---

Parameter	HC52	HC102	HC152	HC202	HC352	HC452	HC702	HC902	
SV040 LMCT	0	0	0	10240	10240	10240	10240	10240	
SV041 LMC2	0	0	0	0	0	0	0	0	
SV042 OVS2	0	0	0	0	0	0	0	0	
SV043 OBS1	0	0	0	0	0	0	0	0	
SV044 OBS2	0	0	0	0	0	0	0	0	
SV045 TRUB	0	0	0	0	0	0	0	0	
SV046	0	0	0	0	0	0	0	0	
SV047 EC1	100	100	100	100	100	100	100	100	
SV048 EMGrt	0	0	0	0	0	0	0	0	
SV049 PGN1sp	15	15	15	15	15	15	15	15	
SV050 PGN2sp	0	0	0	0	0	0	0	0	
SV051 DFBT	0	0	0	0	0	0	0	0	
SV052 DFBN	0	0	0	0	0	0	0	0	
SV053 OD3	0	0	0	0	0	0	0	0	
SV054 ORE	0	0	0	0	0	0	0	0	
SV055 EMGx	0	0	0	0	0	0	0	0	
SV056 EMGt	0	0	0	0	0	0	0	0	
SV057 SHGC	0	0	0	0	0	0	0	0	
SV058 SHGCsp	0	0	0	0	0	0	0	0	
SV059 TCNV	0	0	0	0	0	0	0	0	
SV060 TLMT	0	0	0	0	0	0	0	0	
SV061 DA1NO	0	0	0	0	0	0	0	0	
SV062 DA2NO	0	0	0	0	0	0	0	0	
SV063 DA1MPY	0	0	0	0	0	0	0	0	
SV064 DA2MPY	0	0	0	0	0	0	0	0	

**4.7 Servo Parameters**  
**4.7.4 Standard Parameters Setting**

---

**(f) 3000 r/min medium-inertia motor**

Parameter	HC53	HC103	HC153	HC203	HC353	HC453	HC703		
SV001	PC1	–	–	–	–	–	–	–	
SV002	PC2	–	–	–	–	–	–	–	
SV003	PGN1	33	33	33	33	33	33	33	
SV004	PGN2	0	0	0	0	0	0	0	
SV005	VGN1	100	100	100	100	100	100	100	
SV006	VGN2	0	0	0	0	0	0	0	
SV007	VIL	0	0	0	0	0	0	0	
SV008	VIA	1364	1364	1364	1364	1364	1364	1364	
SV009	IQA	2048	2048	2048	2048	2048	2048	2048	
SV010	IDA	2048	2048	2048	2048	2048	2048	2048	
SV011	IQG	256	256	256	256	256	256	256	
SV012	IDG	512	512	512	512	512	512	512	
SV013	ILMT	500	500	500	500	500	500	500	
SV014	ILMTsp	500	500	500	500	500	500	500	
SV015	FFC	0	0	0	0	0	0	0	
SV016	LMC1	0	0	0	0	0	0	0	
SV017	SPEC	0000	0000	0000	0000	0000	0000	0000	
SV018	PIT	–	–	–	–	–	–	–	
SV019	RNG1	–	–	–	–	–	–	–	
SV020	RNG2	–	–	–	–	–	–	–	
SV021	OLT	60	60	60	60	60	60	60	
SV022	OLL	150	150	150	150	150	150	150	
SV023	OD1	6	6	6	6	6	6	6	
SV024	INP	50	50	50	50	50	50	50	
SV025	MTYP	xxC0	xxC1	xxC2	xxC3	xxC4	xxC5	xxC6	
SV026	OD2	6	6	6	6	6	6	6	
SV027	SSF1	4000	4000	4000	4000	4000	4000	4000	
SV028		0	0	0	0	0	0	0	
SV029	VCS	0	0	0	0	0	0	0	
SV030	IVC	0	0	0	0	0	0	0	
SV031	OVS1	0	0	0	0	0	0	0	
SV032	TOF	0	0	0	0	0	0	0	
SV033	SSF2	0000	0000	0000	0000	0000	0000	0000	
SV034	SSF3	0003	0003	0003	0003	0003	0003	0003	
SV035	SSF4	0000	0000	0040	0040	0040	0040	0040	
SV036	PTYP	0000	0000	0000	0000	0000	0000	0000	
SV037	JL	0	0	0	0	0	0	0	
SV038	FHz	0	0	0	0	0	0	0	
SV039	LMCD	0	0	0	0	0	0	0	

**4.7 Servo Parameters**  
**4.7.4 Standard Parameters Setting**

---

Parameter		HC53	HC103	HC153	HC203	HC353	HC453	HC703		
SV040	LMCT	0	0	0	10240	10240	10240	10240		
SV041	LMC2	0	0	0	0	0	0	0		
SV042	OVS2	0	0	0	0	0	0	0		
SV043	OBS1	0	0	0	0	0	0	0		
SV044	OBS2	0	0	0	0	0	0	0		
SV045	TRUB	0	0	0	0	0	0	0		
SV046		0	0	0	0	0	0	0		
SV047	EC1	100	100	100	100	100	100	100		
SV048	EMGrt	0	0	0	0	0	0	0		
SV049	PGN1sp	15	15	15	15	15	15	15		
SV050	PGN2sp	0	0	0	0	0	0	0		
SV051	DFBT	0	0	0	0	0	0	0		
SV052	DFBN	0	0	0	0	0	0	0		
SV053	OD3	0	0	0	0	0	0	0		
SV054	ORE	0	0	0	0	0	0	0		
SV055	EMGx	0	0	0	0	0	0	0		
SV056	EMGt	0	0	0	0	0	0	0		
SV057	SHGC	0	0	0	0	0	0	0		
SV058	SHGCsp	0	0	0	0	0	0	0		
SV059	TCNV	0	0	0	0	0	0	0		
SV060	TLMT	0	0	0	0	0	0	0		
SV061	DA1NO	0	0	0	0	0	0	0		
SV062	DA2NO	0	0	0	0	0	0	0		
SV063	DA1MPY	0	0	0	0	0	0	0		
SV064	DA2MPY	0	0	0	0	0	0	0		

**4.7 Servo Parameters**  
**4.7.4 Standard Parameters Setting**

**(g) Intelligent servo standard parameters**

		Motor	HS-MF23	HS-RF43	HS-RF73		
		Drive					
Parameter							
SV001	PC1						
SV002	PC2						
SV003	PGN1		33	33	33		
SV004	PGN2		0	0	0		
SV005	VGN1		20	30	30		
SV006	VGN2		0	0	0		
SV007	VIL		0	0	0		
SV008	VIA		1364	1364	1364		
SV009	IQA		2084	4096	4096		
SV010	IDA		2084	4096	4096		
SV011	IQG		512	512	512		
SV012	IDG		512	512	512		
SV013	ILMT1			250	250		
SV014	ILMT2			250	250		
SV015	FFC		0	0	0		
SV016	LMC1		0	0	0		
SV017	SPEC						
SV018	PIT						
SV019	RNG1		8	100	100		
SV020	RNG2		8	100	100		
SV021	OLT		60	60	60		
SV022	OLL		150	150	150		
SV023	OD1						
SV024	INP		50	50	50		
SV025	MTYP		22FE	22F0	22F1		
SV026	OD2						
SV027	SSF1		4000	4000	4000		
SV028			0	0	0		
SV029	VCS		0	0	0		
SV030			0	0	0		
SV031	OVS1		0	0	0		
SV032	TOF		0	0	0		
SV033	SSF2		0000	0000	0000		
SV034	SSF3		0000	0000	0000		
SV035	SSF4		0000	0000	0000		
SV036	PTYP		1000	1000	1000		
SV037	JL		0	0	0		
SV038	FHz		0	0	0		
SV039			0	0	0		

**4.7 Servo Parameters**  
**4.7.4 Standard Parameters Setting**

---

Motor Drive		HS-MF23	HS-RF43	HS-RF73		
Parameter						
SV040	LMCT	0	0	0		
SV041	LMC2	0	0	0		
SV042	OVS2	0	0	0		
SV043	OBS1	0	0	0		
SV044	OBS2	0	0	0		
SV045	TRUB	0	0	0		
SV046		0	0	0		
SV047	EC1	100	100	100		
SV048	EMGrt	0	0	0		
SV049	PGN1SP	15	15	15		
SV050	PGN2SP	0	0	0		
SV051	DFBT	0	0	0		
SV052	DFBN	0	0	0		
SV053	OD3	0	0	0		
SV054	ORE	0	0	0		
SV055	EMGx	0	0	0		
SV056	EMGt	0	0	0		
SV057	SHGC	0	0	0		
SV058	SHGCSP	0	0	0		
SV059	TCNV	0	0	0		
SV060	TLMT	0	0	0		
SV061	DA1NO	0	0	0		
SV062	DA2NO	0	0	0		
SV063	DA1MPY	0	0	0		
SV064	DA2MPY	0	0	0		

**4.7 Servo Parameters**  
**4.7.4 Standard Parameters Setting**

**(2) Parameters for each servo system**

Parameter	Relative position detection			Absolute position detection		
	Semi-closed loop	Closed loop		Semi-closed loop	Closed loop	
		Ball screw end detection	Scale detection		Ball screw end detection	Scale detection
SV017 SPEC (HEX)	<ul style="list-style-type: none"> <li>bit5-HA053/13 detector connector position</li> </ul>	<ul style="list-style-type: none"> <li>bit1 (DUAL FB)</li> <li>bit4 (polarity)</li> <li>bit5-HA053/13 detector connector position</li> </ul>	<ul style="list-style-type: none"> <li>bit1 (DUAL FB)</li> <li>bit4 (polarity)</li> <li>bit5-HA053/13 detector connector position</li> <li>bit8-Z-phase type</li> </ul>	<ul style="list-style-type: none"> <li>bit7=1</li> </ul>	<ul style="list-style-type: none"> <li>bit1 (DUAL FB)</li> <li>bit4 (polarity)</li> <li>bit5-HA053/13 detector connector position</li> <li>bit7=1</li> </ul>	<ul style="list-style-type: none"> <li>bit1 (DUAL FB)</li> <li>bit4 (polarity)</li> <li>bit5-HA053/13 detector connector position</li> <li>bit8-Z-phase type</li> </ul>
SV019 RNG1	10 (HA053/13) OR 100 (Others) OR 1000	100 OR 1000	Ball screw pitch OR Scale resolution	100 OR 1000	100 OR 1000	Ball screw pitch OR Scale resolution
SV020 RNG2	Set the same value as SV019	10 (HA053/13) OR 100 (Others)	10 (HA053/13) OR 100 (Others)	Set the same value as SV019	10 (HA053/13) OR 100 (Others)	10 (HA053/13) OR 100 (Others)
SV025 MTYP	33XX (HA053/13) OR 00XX (Others)	43XX (HA053/13) OR 40XX (Others)	83XX (HA053/13) OR 80XX (Others)	11XX	53XX (HA053/13) OR 50XX (Others)	93XX (HA053/13) OR 90XX (Others)

Selecting 1 $\mu$ m or 0.1 $\mu$ m as a unit depends on parameters for control at the NC side.  
 But when HA053/13 is used, 0.1 $\mu$ m is failure.

## 4.8 Spindle Parameters

### 4.8.1 Spindle NC Parameters

## 4.8 Spindle Parameters

Item	Details	Page
Spindle NC parameters	Parameters for control at the NC side	4.8.1
Spindle parameters	Parameters for controlling on the spindle side when serial-connected to the spindle controller	4.8.2
Spindle-type servo parameters	Parameters for controlling on the NC side when serial-connected to the NC axis.	4.8.4

### 4.8.1 Spindle NC Parameters

The valid spindle NC parameters differ according to the motor type. Set the correct parameters following the correspondence table below.

O: Valid      Spindle-type servo: MDS-B-SVJ2 (for spindle-type servo)

Parameter	Compatible model		
	MDS-B-SP/SPH	MDS-B-SPJ2	Spindle-type servo
slimt 1	○	○	○
slimt 2	○	○	–
slimt 3	○	○	–
slimt 4	○	○	–
smax 1	○	○	○
smax 2	○	○	–
smax 3	○	○	–
smax 4	○	○	–
ssift 1	○	○	–
ssift 2	○	○	–
ssift 3	○	○	–
ssift 4	○	○	–
stap 1	○	○	○
stap 2	○	○	–
stap 3	○	○	–
stap 4	○	○	–
stapt 1	○	○	○
stapt 2	○	○	–
stapt 3	○	○	–
stapt 4	○	○	–
sori	○	○	–
sgear	○	○	–
smini	○	○	○
serr	○	○	○
sname	○	○	○
sprcmm	○	○	–
senc_pno	○	○	–
sana_pno	○	○	–
spflg	○	○	○
senc_no	○	○	–
sana_no	○	○	–
smcp_no	○	○	○

Parameter	Compatible model		
	MDS-B-SP/SPH	MDS-B-SPJ2	Spindle-type servo
spt	○	○	○
sprlv	○	○	–
spplv	○	○	–
sptc1	○	○	○
sptc2	○	○	○
spdiv1	○	○	○
spdiv2	○	○	○
spplr	○	○	○
spst	○	○	–
GBsp	○	○	–
sptc3	○	○	○
sptc4	○	○	○
sptc5	○	○	○
sptc6	○	○	○
sptc7	○	○	○
spdiv3	○	○	○
spdiv4	○	○	○
spdiv5	○	○	○
spdiv6	○	○	○
spdiv7	○	○	○



**4.8 Spindle Parameters**  
**4.8.1 Spindle NC Parameters**

---

#	Item	Details	Setting range (unit)
3001	slimt 1 Limit rotation speed	<div style="border: 1px solid black; padding: 2px; margin-bottom: 5px;"><b>For spindle-type servo</b></div> Set the spindle rotation speed in respect to the motor's maximum rotation speed for gear 00. (This is used for calculating the acceleration/deceleration time constant.)	0 to 99999 (r/min)
		<div style="border: 1px solid black; padding: 2px; margin-bottom: 5px;"><b>In other cases</b></div> Set the spindle rotation speed in respect to the motor's maximum rotation speed for gear 00. (Set the spindle rotation speed at the S analog output 10V.)	
3002 3003 3004	slimt 2 3 4 Limit rotation speed	Set the spindle speed for maximum motor speed with gears 01, 10, 11. (Corresponds to S analog output 10V.)	
3005 3006 3007 3008	smax 1 2 3 4 Maximum speed	Set the maximum spindle speed with gears 00, 01, 10, 11. Set to slimt $\geq$ smax.	
3009 3010 3011 3012	ssift 1 2 3 4 Shift speed	Set the spindle speed for gear shifting with gears 00, 01, 10, 11.	0 to 32767 (r/min)
3013 3014 3015 3016	stap 1 2 3 4 Tap speed	Set the maximum spindle speed during tap cycle with gears 00, 01, 10, 11.	0 to 99999 (r/min)
3017 3018 3019 3020	stapt 1 2 3 4 Tap time constant	Set time constants for constant inclination synchronous tap cycles for gears 00, 01, 10, 11 (linear acceleration/deceleration pattern).	0 to 5000 (ms)

## 4.8 Spindle Parameters

### 4.8.1 Spindle NC Parameters

#### Relationship between spindle limit speed and spindle maximum speed

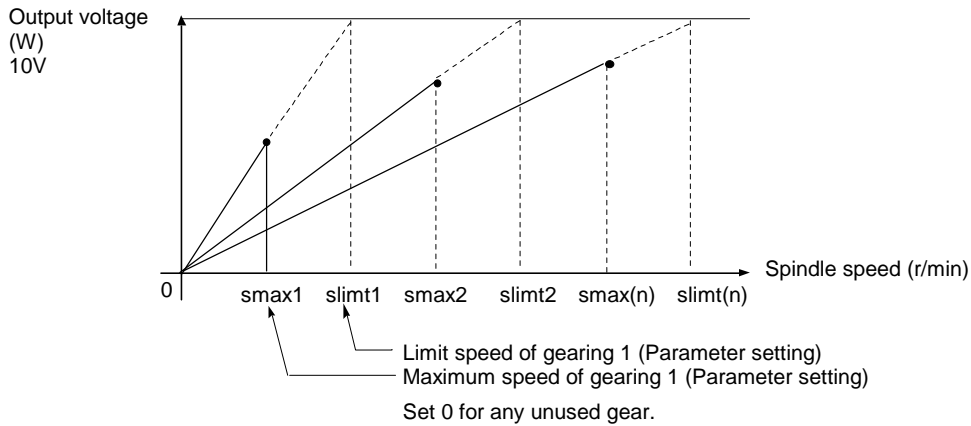

#### Relation between the spindle limit speed and the spindle tap time constant (for the constant inclination synchronous tap cycle)

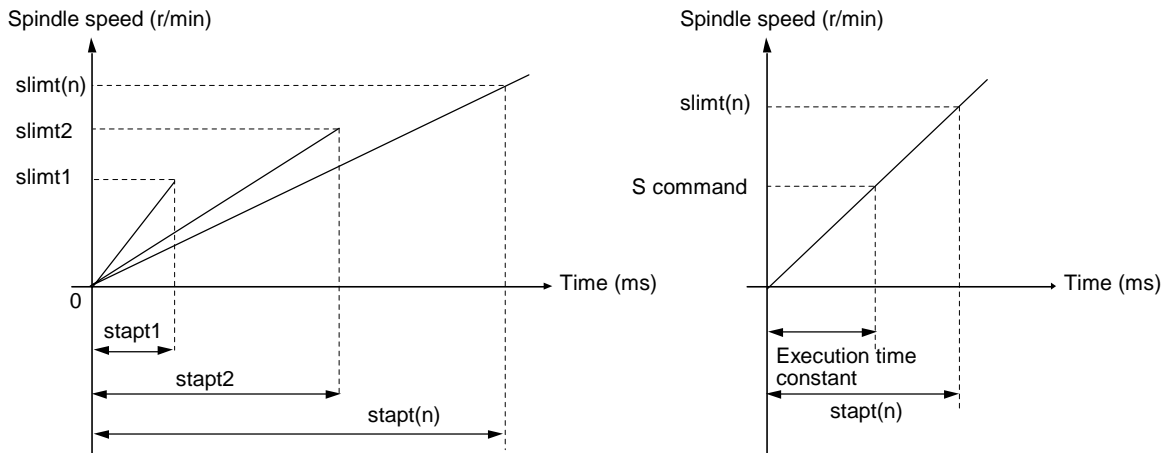

#	Item	Details	Setting range (unit)
3021	sori	Orientation speed Set the spindle orientation speed. Set the speed for when the spindle rotates at the constant speed.	0 to 32767 (r/min)
3022	sgear	Encoder gear ratio Set the gear ratio of the spindle to the encoder.	0: 1/1 1: 1/2 2: 1/4 3: 1/8
3023	smini	Minimum speed Set the minimum speed of the spindle. If an S command instructs the rotation speed below this setting, the spindle rotates at the minimum speed set by this parameter.	0 to 32767 (r/min)

## 4.8 Spindle Parameters

### 4.8.1 Spindle NC Parameters

#	Item	Details	Setting range (unit)	
3024	serr	Spindle speed arrival detection width	Set the spindle speed arrival detection width. When the actual spindle speed is greater than the rate set by the speed set by the command, an upper or lower limit error signal is output to the PLC.	0: Not check 1 to 99 (%)
3025	sname	S command name	Assign a name to an S command name to spindle, 2nd spindle, rotation tool 1 and rotation tool 2. Set □=in one digit for S□=xxxxxx. <b>(Note)</b> Do not assign the same name to two or more S commands.	0 to 9
3026	sprcmm	Spindle forward/reverse M command	Assign the M code for the spindle forward / reverse rotation command. Assign the M code with the three digits for each of forward and reverse command.  <div style="text-align: center;"> </div>	0 to 999999
3027	senc_pno	Encoder port number	Set the port number of a connection card.	1 to 2
3028	sana_pno	Analog output port number (Not used.)	Not used. Set to "0".	0
3029	spflg	Spindle connection information	bit0    1: HDLC connection <b>(Note 1)</b> 0: Analog connection  bit2    1: Direct connection to encoder Also set the following parameter. 3027 senc_no 0: Via passing HDLC connection axis Also set the following parameter. 3238 SP038 SFNC6/bit2 ON  bit3    Sub-motor spindle designation <b>(Note 1)</b> 1: Sub 0: Main It is no use specifying sub-motor for the spindle which the 1 amplifier 2 motor function is invalid.  bit4    1: SPJ Spindle/C axis control valid <b>(Note 1)</b> 0: SPJ Spindle/C axis control invalid  bit7    1: Spindle-type servo valid 0: Spindle-type servo invalid	00 to FF HEX setting
3030	senc_no	Encoder connection card number (Not used.)	Not used. Set to "0".	0
3031	sana_no	Analog output number	Designate the analog output R register for outputting the S analog value. Set 1 to 8 for A01 to A08. Set to "0" when not using S analog output.	0: Not used. 1 to 8 : A01 to A08

**(Note 1)** When using the spindle-type servo, always set "0".

## 4.8 Spindle Parameters

### 4.8.1 Spindle NC Parameters

#	Item	Details	Setting range (unit)				
3032	smcp_no	Spindle MCP number  <table border="1" style="margin-left: auto; margin-right: auto;"> <thead> <tr> <th style="text-align: center;">2nd digit</th> <th style="text-align: center;">1st digit</th> </tr> </thead> <tbody> <tr> <td style="text-align: center;">Channel No.</td> <td style="text-align: center;">Axis No.</td> </tr> </tbody> </table>	2nd digit	1st digit	Channel No.	Axis No.	11 to 17 21 to 27 31 to 37 41 to 47
2nd digit	1st digit						
Channel No.	Axis No.						
3033	spt	Spindle synchronous acceleration/ deceleration time constant	0 to 9999 (ms)				
3034	sprlv	Spindle speed synchronizing complete signal turns ON when the differ between the commanded value of slave (synchronized) spindle speed and both values, actual speed of master spindle and that of slave spindle, becomes the set level or less.	0 to 4095 (pulse)				
3035	spplv	Spindle speed synchronizing complete signal turns ON when the phase difference of master spindle or that of slave spindle becomes the set level or less.	0 to 4095 (pulse)				
3036	sptc1	Spindle synchronous multi-step acceleration/ deceleration changing speed 1	0 to 99999 (r/min)				
3037	sptc2	Spindle synchronous multi-step acceleration/ deceleration changing speed 2	0 to 99999 (r/min)				
3038	spdiv1	Time constant magnification in case of changing speed 1	0 to 127				
3039	spdiv2	Time constant magnification in case of changing speed 2	0 to 127				

**4.8 Spindle Parameters**  
**4.8.1 Spindle NC Parameters**

#	Item	Details	Setting range (unit)
3040	spplr	Spindle motor/spindle relative polarity  Set the relative polarity of the spindle motor and the spindle.  Motor rotates clockwise and spindle, too: Polarity is positive. Motor rotates clockwise and spindle rotates counterclockwise: Polarity is negative.	0: Polarity is positive. 1: Polarity is negative.
3041	sppst	Spindle encoder Z-phase position  Set the deviation amount from the spindle standard position (machine zero) to the encoder Z-phase. (The deviation amount should be required with the clockwise a positive direction from the front of spindle.)	0 to 359999 (1/1000°)
3042	GBsp	Reference, G/B spindle designation  Designate the master spindle and G/B spindle.	1: Reference spindle 2: G/B spindle 0: Other
3043	sptc3	Spindle synchronous multi-step acceleration/deceleration changing speed 3  Set the speed of the spindle that carries out the acceleration/deceleration time constant change at the 3rd step.	0 to 99999 (r/min)
3044	sptc4	Spindle synchronous multi-step acceleration/deceleration changing speed 4  Set the speed of the spindle that carries out the acceleration/deceleration time constant change at the 4th step.	0 to 99999 (r/min)
3045	sptc5	Spindle synchronous multi-step acceleration/deceleration changing speed 5  Set the speed of the spindle that carries out the acceleration/deceleration time constant change at the 5th step.	0 to 99999 (r/min)
3046	sptc6	Spindle synchronous multi-step acceleration/deceleration changing speed 6  Set the speed of the spindle that carries out the acceleration/deceleration time constant change at the 6th step.	0 to 99999 (r/min)
3047	sptc7	Spindle synchronous multi-step acceleration/deceleration changing speed 7  Set the speed of the spindle that carries out the acceleration/deceleration time constant change at the 7th step.	0 to 99999 (r/min)
3048	sptdiv3	Magnification for time constant changing speed 3  Set the magnification of the acceleration/deceleration time constant between "sptc3" (changing speed 3) and "sptc4" (changing speed 4) to "spt" (spindle synchronous acceleration/deceleration time constant).	0 to 127

## 4.8 Spindle Parameters

### 4.8.1 Spindle NC Parameters

#	Item	Details	Setting range (unit)	
3049	spdiv4	Magnification for time constant changing speed 4	Set the magnification of the acceleration/deceleration time constant between "sptc4" (changing speed 4) and "sptc5" (changing speed 5) to "spt" (spindle synchronous acceleration/deceleration time constant).	0 to 127
3050	spdiv5	Magnification for time constant changing speed 5	Set the magnification of the acceleration/deceleration time constant between "sptc5" (changing speed 5) and "sptc6" (changing speed 6) to "spt" (spindle synchronous acceleration/deceleration time constant).	0 to 127
3051	spdiv6	Magnification for time constant changing speed 6	Set the magnification of the acceleration/deceleration time constant between "sptc6" (changing speed 6) and "sptc7" (changing speed 7) to "spt" (spindle synchronous acceleration/deceleration time constant).	0 to 127
3052	spdiv7	Magnification for time constant changing speed 7	Set the magnification of the acceleration/deceleration time constant between "sptc7" (changing speed 7) and maximum spindle speed to "spt" (spindle synchronous acceleration/deceleration time constant).	0 to 127
3053			Not used.	
3054			Not used.	
3055	sps_1		bit0 Tool spindle synchronous control II (hobb machining) compensation selection 0: No compensation 1: Compensate hobb axis delay (advance) with workpiece axis.	00 to FF HEX setting.

- (Note)** #3033~#3041 are the parameters required during the spindle synchronous control.
- (1) "#3033 spt" (Spindle synchronous acceleration/deceleration time constant) follows the larger set value among the synchronous standard spindle and synchronous spindle.
  - (2) "#3036 sptc1" (Spindle synchronous acceleration/deceleration changing speed 1) "#3038 spdiv1" (magnification for time constant changing speed 1) to "#3052 spdiv7" (magnification for time constant changing speed 7) follows the setting value of the spindle selected by "#3033 spt".
  - (3) "#3034 sprlv" (Spindle synchronous speed arrival level) and "#3035 spplv" (Spindle synchronous phase arrival level) follows the set value of slave spindle. However, in case C-axis is selected for the workpiece axis during hob machining (G114.3), they follow the set value of master spindle.
  - (4) "#3040 spplr" (Spindle motor/spindle relative polarity) is valid for each spindle.
  - (5) When setting these parameters, it is necessary to measure speed control acceleration/ deceleration pattern of the master spindle motor and G/B spindle motor (when using the guide bushing spindle synchronous function).

## 4.8 Spindle Parameters

### 4.8.2 Spindle Parameters

#### 4.8.2 Spindle Parameters

The valid spindle parameters will differ according to the motor and amplifier type. Follow the correspondence table given below, and set the correct parameters.

O: Valid, Δ: Fixed value

Spindle-type servo: MDS-B-SVJ2 (for spindle-type servo)

Parameter	Corresponding model		
	MDS-B-SP/SPH	MDS-B-SPJ2	Spindle-type servo
SP001	○	○	–
SP002	○	○	–
SP003	○	–	–
SP004	○	○	○
SP005	○	○	○
SP006	○	○	○
SP007	○	○	○
SP008	–	–	–
SP009	○	○	–
SP010	○	○	–
SP011	–	–	–
SP012	–	–	–
SP013	–	–	–
SP014	–	–	–
SP015	–	–	–
SP016	–	–	–
SP017	○	○	○
SP018	○	○	○
SP019	○	○	–
SP020	○	○	○
SP021	○	○	○
SP022	○	○	–
SP023	○	○	–
SP024	–	–	–
SP025	○	○	–
SP026	○	○	–
SP027	○	○	–
SP028	○	○	–
SP029	○	○	–
SP030	○	○	–
SP031	○	○	–
SP032	○	○	–
SP033	○	○	–
SP034	○	○	–
SP035	○	○	–
SP036	○	○	–
SP037	○	○	–
SP038	○	○	–
SP039	○	○	–
SP040	○	○	–
SP041	○	○	–
SP042	○	–	–

Parameter	Corresponding model		
	MDS-B-SP/SPH	MDS-B-SPJ2	Spindle-type servo
SP043	○	–	–
SP044	○	○	–
SP045	○	–	–
SP046	○	○	–
SP047	○	○	–
SP048	○	○	○
SP049	○	○	○
SP050	○	○	○
SP051	○	○	–
SP052	○	○	–
SP053	○	○	–
SP054	○	○	–
SP055	○	○	–
SP056	○	○	–
SP057	Δ	Δ	–
SP058	○	–	–
SP059	○	–	–
SP060	○	–	–
SP061	○	–	–
SP062	–	–	–
SP063	○	○	–
SP064	○	○	–
SP065	○	○	–
SP066	○	○	–
SP067	○	○	–
SP068	○	○	–
SP069	○	○	–
SP070	○	–	–
SP071	Δ	–	–
SP072	Δ	–	–
SP073	Δ	–	–
SP074	Δ	–	–
SP075	Δ	–	–
SP076	○	–	–
SP077	Δ	Δ	–
SP078	Δ	Δ	–
SP079	Δ	Δ	–
SP080	–	–	–
SP081	Δ	–	–
SP082	Δ	–	–
SP083	–	–	–
SP084	–	–	–

## 4.8 Spindle Parameters

### 4.8.2 Spindle Parameters

O: Valid, Δ: Fixed value

Spindle-type servo: MDS-B-SVJ2 (for spindle-type servo)

Parameter	Corresponding model		
	MDS-B-SP/SPH	MDS-B-SPJ2	Spindle-type servo
SP085	–	–	–
SP086	–	–	–
SP087	○	○	–
SP088	○	○	–
SP089	–	–	–
SP090	–	○	–
SP091	○	–	–
SP092	○	–	–
SP093	Δ	Δ	–
SP094	○	–	–
SP095	Δ	Δ	–
SP096	○	○	–
SP097	○	○	○
SP098	○	○	–
SP099	○	○	–
SP100	○	○	–
SP101	○	○	–
SP102	○	○	–
SP103	○	○	○
SP104	○	○	–
SP105	○	○	–
SP106	○	○	–
SP107	○	○	–
SP108	○	○	–
SP109	○	○	–
SP110	–	○	–
SP111	–	○	–
SP112	–	○	–
SP113	–	○	–
SP114	○	○	○
SP115	Δ	Δ	–
SP116	–	–	–
SP117	Δ	–	–
SP118	Δ	Δ	–
SP119	○	–	–
SP120	○	–	–
SP121	○	–	–
SP122	○	–	–
SP123	○	–	–
SP124	○	–	–
SP125	○	–	–
SP126	–	–	–
SP127	–	–	–
SP128	–	–	–
SP129	○	–	○
SP130	○	–	–
SP131	○	–	–

Parameter	Corresponding model		
	MDS-B-SP/SPH	MDS-B-SPJ2	Spindle-type servo
SP132	○	–	–
SP133	○	–	–
SP134	○	–	–
SP135	○	–	–
SP136	○	–	–
SP137	○	–	–
SP138	○	–	–
SP139	○	–	–
SP140	○	–	–
SP141	○	–	–
SP142	○	–	–
SP143	○	–	–
SP144	○	–	–
SP145	○	–	–
SP146	○	–	–
SP147	○	–	–
SP148	○	–	–
SP149	○	–	○
SP150	○	–	○
SP151	○	–	○
SP152	○	–	○
SP153	○	–	–
SP154	○	–	–
SP155	○	–	–
SP156	Δ	–	–
SP157	–	–	–
SP158	–	–	–
SP159	○	–	–
SP160	○	–	–
SP161	○	–	–
SP162	○	–	–
SP163	○	–	–
SP164	○	–	–
SP165	○	–	–
SP166	○	–	–
SP167	○	–	–
SP168	○	–	–
SP169	○	–	–
SP170	○	–	–
SP171	–	–	–
SP172	–	–	–
SP173	–	–	–
SP174	–	–	–
SP175	–	–	–
SP176	–	–	–
SP177	○	○	–
SP178	○	○	–



## 4.8 Spindle Parameters

### 4.8.2 Spindle Parameters

O: Valid, Δ: Fixed value

Spindle-type servo: MDS-B-SVJ2 (for spindle-type servo)

Parameter	Corresponding model		
	MDS-B-SP/SPH	MDS-B-SPJ2	Spindle-type servo
SP179	○	○	–
SP180	○	○	–
SP181	○	○	–
SP182	○	○	–
SP183	○	○	–
SP184	–	Δ	–
SP185	○	○	–
SP186	○	○	–
SP187	○	○	–
SP188	○	○	–
SP189	○	–	–
SP190	○	–	–
SP191	–	–	–
SP192	–	–	–
SP193	○	○	–
SP194	○	○	–
SP195	○	○	–
SP196	○	○	–
SP197	–	–	–
SP198	○	○	–
SP199	○	○	–
SP200	○	○	–
SP201	○	○	–
SP202	○	○	–
SP203	○	○	–
SP204	–	–	–
SP205	–	–	–
SP206	–	–	–
SP207	–	–	–
SP208	–	–	–
SP209	–	–	–
SP210	–	–	–
SP211	–	–	–
SP212	–	–	–
SP213	–	–	–
SP214	○	○	–
SP215	○	○	–
SP216	○	○	–
SP217	○	○	–
SP218	○	○	–
SP219	○	○	–
SP220	○	○	–
SP221	○	–	–
SP222	○	–	–
SP223	Δ	–	–
SP224	Δ	–	–
SP225	○	–	–

Parameter	Corresponding model		
	MDS-B-SP/SPH	MDS-B-SPJ2	Spindle-type servo
SP226	○	–	–
SP227	○	–	–
SP228	○	–	–
SP229	○	–	–
SP230	–	–	–
SP231	–	–	–
SP232	–	–	–
SP233	○	–	–
SP234	○	–	–
SP235	○	–	–
SP236	Δ	–	–
SP237	–	–	–
SP238	–	–	–
SP239	–	–	–
SP240	–	–	–
SP241	–	–	–
SP242	Δ	–	–
SP243	Δ	–	–
SP244	Δ	–	–
SP245	○	–	–
SP246	Δ	–	–
SP247	–	–	–
SP248	–	–	–
SP249	○	–	–
SP250	○	–	–
SP251	–	–	–
SP252	–	–	–
SP253	○	○	–
SP254	○	○	–
SP255	○	○	–
SP256	○	○	–
SP257	Δ	Δ	–
SP258	Δ	Δ	–
SP259	Δ	Δ	–
SP260	Δ	Δ	–
SP261	Δ	Δ	–
SP262	Δ	Δ	–
SP263	Δ	Δ	–
SP264	Δ	Δ	–
SP265	Δ	Δ	–
SP266	Δ	Δ	–
SP267	Δ	Δ	–
SP268	Δ	Δ	–
SP269	Δ	Δ	–
SP270	Δ	Δ	–
SP271	Δ	Δ	–
SP272	Δ	Δ	–

## 4.8 Spindle Parameters

### 4.8.2 Spindle Parameters

O: Valid, Δ: Fixed value

Spindle-type servo: MDS-B-SVJ2 (for spindle-type servo)

Parameter	Corresponding model		
	MDS-B-SP/SPH	MDS-B-SPJ2	Spindle-type servo
SP273	Δ	Δ	–
SP274	Δ	Δ	–
SP275	Δ	Δ	–
SP276	Δ	Δ	–
SP277	Δ	Δ	–
SP278	Δ	Δ	–
SP279	Δ	Δ	–
SP280	Δ	Δ	–
SP281	Δ	Δ	–
SP282	Δ	Δ	–
SP283	Δ	Δ	–
SP284	Δ	Δ	–
SP285	Δ	Δ	–
SP286	Δ	Δ	–
SP287	Δ	Δ	–
SP288	Δ	Δ	–
SP289	Δ	Δ	–
SP290	Δ	Δ	–
SP291	Δ	Δ	–
SP292	Δ	Δ	–
SP293	Δ	Δ	–
SP294	○	–	–
SP295	○	–	–
SP296	Δ	–	–
SP297	Δ	–	–
SP298	Δ	–	–
SP299	Δ	–	–
SP300	Δ	–	–
SP301	Δ	–	–
SP302	Δ	–	–
SP303	Δ	–	–
SP304	Δ	–	–
SP305	Δ	–	–
SP306	Δ	–	–
SP307	Δ	–	–
SP308	Δ	–	–
SP309	Δ	–	–
SP310	Δ	–	–
SP311	Δ	–	–
SP312	Δ	–	–
SP313	Δ	–	–
SP314	Δ	Δ	–
SP315	Δ	Δ	–
SP316	Δ	Δ	–
SP317	Δ	Δ	–
SP318	Δ	Δ	–
SP319	Δ	Δ	–

Parameter	Corresponding model		
	MDS-B-SP/SPH	MDS-B-SPJ2	Spindle-type servo
SP320	Δ	Δ	–
SP321	Δ	–	–
SP322	Δ	–	–
SP323	Δ	–	–
SP324	Δ	–	–
SP325	Δ	–	–
SP326	Δ	–	–
SP327	Δ	–	–
SP328	Δ	–	–
SP329	Δ	–	–
SP330	Δ	–	–
SP331	Δ	–	–
SP332	Δ	–	–
SP333	Δ	–	–
SP334	Δ	–	–
SP335	Δ	–	–
SP336	Δ	–	–
SP337	Δ	–	–
SP338	Δ	–	–
SP339	Δ	–	–
SP340	Δ	–	–
SP341	Δ	–	–
SP342	Δ	–	–
SP343	Δ	–	–
SP344	Δ	–	–
SP345	Δ	–	–
SP346	Δ	–	–
SP347	Δ	–	–
SP348	Δ	–	–
SP349	Δ	–	–
SP350	Δ	–	–
SP351	Δ	–	–
SP352	Δ	–	–
SP353	Δ	–	–
SP354	Δ	–	–
SP355	Δ	–	–
SP356	Δ	–	–
SP357	Δ	–	–
SP358	○	–	–
SP359	○	–	–
SP360	Δ	–	–
SP361	Δ	–	–
SP362	Δ	–	–
SP363	Δ	–	–
SP364	Δ	–	–
SP365	Δ	–	–
SP366	Δ	–	–

## 4.8 Spindle Parameters

### 4.8.2 Spindle Parameters

---

O: Valid, Δ: Fixed value

Spindle-type servo: MDS-B-SVJ2 (for spindle-type servo)

Parameter	Corresponding model		
	MDS-B-SP/SPH	MDS-B-SPJ2	Spindle-type servo
SP367	Δ	–	–
SP368	Δ	–	–
SP369	Δ	–	–
SP370	Δ	–	–
SP371	Δ	–	–
SP372	Δ	–	–
SP373	Δ	–	–
SP374	Δ	–	–
SP375	Δ	–	–

Parameter	Corresponding model		
	MDS-B-SP/SPH	MDS-B-SPJ2	Spindle-type servo
SP376	Δ	–	–
SP377	Δ	–	–
SP378	Δ	–	–
SP379	Δ	–	–
SP380	Δ	–	–
SP381	Δ	–	–
SP382	Δ	–	–
SP383	Δ	–	–
SP384	Δ	–	–

## 4.8 Spindle Parameters

### 4.8.2 Spindle Parameters

For parameters marked with an "\*" in the tables, turn the NC power OFF after setting. The parameters will be valid after the power is turned ON again.

The "fixed control constants" and "fixed control bits" in this section are set by Mitsubishi. Set these to "0" unless designated in particular.

#	Item		Details	Setting range (unit)	Standard setting	
3201	SP001	PGM	Magnetic detector and motor built-in encoder orientation-mode position loop gain	As the set value is larger, the orientation time becomes shorter and servo rigidity is increased. On the contrary, however, vibration is increased and the machine becomes likely to overshoot.	0 to 1000 (0.1 1/s)	100
3202	SP002	PGE	Encoder orientation-mode position loop gain	As the set value is larger, the orientation time becomes shorter and servo rigidity is increased. On the contrary, however, vibration is increased and the machine becomes likely to overshoot.	0 to 1000 (0.1 1/s)	100
3203	SP003	PGC0	C-axis non-cutting position loop gain	Set the position loop gain in C-axis non-cutting mode. During non-cutting (rapid traverse, etc.) with the C axis control, this position loop gain setting is valid.	1 to 100 (1/s)	15
3204	SP004	OINP	Orientation in-position width	Set the position error range in which an orientation completion signal is output.	1 to 2880 (1/16°)	16
3205	SP005	OSP*	Orientation mode changing speed limit value	Set the motor speed limit value to be used when the speed loop is changed to the position loop in orientation mode. When this parameter is set to "0", SP017 (TSP) becomes the limit value.	0 to 32767 (r/min)	0
3206	SP006	CSP	Orientation mode deceleration rate	As the set value is larger, the orientation time becomes shorter. On the contrary, however, the machine becomes likely to overshoot.	1 to 1000	20
3207	SP007	OPST	Inposition shift amount for orientation	<b>For SP/SPH, spindle-type servo</b> Set the stop position for orientation. (1) Motor built-in encoder, encoder: Set the value by dividing 360° by 4096. (2) Magnetic detector: Divide -5 to +5° by 1024 and put 0° for 0.	(1) 0 to 4095 (2) -512 to 512	0
				<b>For others</b> Set the stop position for orientation. Set the value by dividing 360° by 4096.	0 to 4095	0
3208	SP008			Not used. Set to "0".	0	0
3209	SP009	PGT	Synchronous tapping position loop gain	Set the spindle position loop gain in synchronous tapping mode.	1 to 10 (1/s)	15
3210	SP010	PGS	Spindle synchronous position loop gain	Set the spindle position loop gain in spindle synchronization mode.	1 to 100 (1/s)	15
3211 to 3216	SP011 to SP016			Use not possible.	0	0

## 4.8 Spindle Parameters

### 4.8.2 Spindle Parameters

#	Item			Details	Setting range (unit)	Standard setting
3217	SP017	TSP*	Maximum motor speed	<b>For spindle-type servo</b> Set the maximum motor speed of the spindle.	1 to 10000 (r/min)	5000
				<b>For other cases</b> Set the maximum motor speed of the spindle motor.	1 to 32767 (r/min)	6000
3218	SP018	ZSP*	Motor zero speed	Set the motor speed for which zero-speed output is performed.	1 to 1000 (r/min)	50
3219	SP019	CSN1*	Speed cushion 1	Set the time constant for a speed command from "0" to the maximum speed. (This parameter is invalid in position loop mode.)	0 to 32767 (10ms)	30
3220	SP020	SDTS*	Speed detection set value	<b>For spindle-type servo</b> Set the motor speed so for which speed detection output is performed. Usually, the setting value is 10% of SP017 (TSP).	1 to 10000 (r/min)	500
				<b>For other cases</b> Set the motor speed for outputting the speed detection. Normally, set a value 10% of SP017 (TSP).	0 to 32767 (r/min)	600
3221	SP021	TLM1*	Torque limit 1	Set the torque limit rate for torque limit signal 001.	0 to 120 (%)	10
3222	SP022	VGNP1*	Speed loop gain proportional term under speed control	Set the speed loop proportional gain in speed control mode. When the gain is increased, response is improved but vibration and sound become larger.	0 to 1000 (1/s)	63
3223	SP023	VGNI1*	Speed loop gain integral term under speed control	Set the speed loop integral gain in speed control mode. Usually, set a value in proportion to SP022 (VGNP1).	0 to 1000 (0.1 1/s)	60
3224	SP024			Not used. Set to "0".	0	0
3225	SP025	GRA1*	Spindle gear teeth count 1	Set the number of gear teeth of the spindle corresponding to gear 000.	1 to 32767	1
3226	SP026	GRA2*	Spindle gear teeth count 2	Set the number of gear teeth of the spindle corresponding to gear 001.	1 to 32767	1
3227	SP027	GRA3*	Spindle gear teeth count 3	Set the number of gear teeth of the spindle corresponding to gear 010.	1 to 32767	1
3228	SP028	GRA4*	Spindle gear teeth count 4	Set the number of gear teeth of the spindle corresponding to gear 011.	1 to 32767	1
3229	SP029	GRB1*	Motor shaft gear teeth count 1	Set the number of gear teeth of the motor shaft corresponding to gear 000.	1 to 32767	1
3230	SP030	GRB2*	Motor shaft gear teeth count 2	Set the number of gear teeth of the motor shaft corresponding to gear 001.	1 to 32767	1
3231	SP031	GRB3*	Motor shaft gear teeth count 3	Set the number of gear teeth of the motor shaft corresponding to gear 010.	1 to 32767	1
3232	SP032	GRB4*	Motor shaft gear teeth count 4	Set the number of gear teeth of the motor shaft corresponding to gear 011.	1 to 32767	1

**4.8 Spindle Parameters**  
**4.8.2 Spindle Parameters**

#	Item	Details	Setting range (unit)	Standard setting																																																																																																				
3233	SP033 SFNC1*	Spindle function 1  Set the spindle function 1 in bit units.  <table style="width: 100%; text-align: center; border-collapse: collapse;"> <tr> <td style="border: none;">F</td><td style="border: none;">E</td><td style="border: none;">D</td><td style="border: none;">C</td><td style="border: none;">B</td><td style="border: none;">A</td><td style="border: none;">9</td><td style="border: none;">8</td> </tr> <tr> <td style="border: 1px solid black; width: 25px; height: 20px;">poff</td><td style="border: 1px solid black; width: 25px; height: 20px;">hzs</td><td style="border: 1px solid black; width: 25px; height: 20px;"></td><td style="border: 1px solid black; width: 25px; height: 20px;">ront</td><td style="border: 1px solid black; width: 25px; height: 20px;"></td><td style="border: 1px solid black; width: 25px; height: 20px;"></td><td style="border: 1px solid black; width: 25px; height: 20px;"></td><td style="border: 1px solid black; width: 25px; height: 20px;"></td> </tr> <tr> <td style="border: none;">7</td><td style="border: none;">6</td><td style="border: none;">5</td><td style="border: none;">4</td><td style="border: none;">3</td><td style="border: none;">2</td><td style="border: none;">1</td><td style="border: none;">0</td> </tr> <tr> <td style="border: 1px solid black; width: 25px; height: 20px;"></td><td style="border: 1px solid black; width: 25px; height: 20px;"></td><td style="border: 1px solid black; width: 25px; height: 20px;"></td><td style="border: 1px solid black; width: 25px; height: 20px;"></td><td style="border: 1px solid black; width: 25px; height: 20px;"></td><td style="border: 1px solid black; width: 25px; height: 20px;">sftk</td><td style="border: 1px solid black; width: 25px; height: 20px;">dflt</td><td style="border: 1px solid black; width: 25px; height: 20px;">1a2m</td> </tr> </table> <p><b>(Note)</b> Always set "0" for the empty bits.</p> <table border="1" style="width: 100%; border-collapse: collapse; font-size: 8px;"> <thead> <tr> <th>bit</th> <th>Name</th> <th>Meaning when set to 0</th> <th>Meaning when set to 1</th> </tr> </thead> <tbody> <tr> <td>0</td> <td>1a2m</td> <td>1 amplifier 2 motor function: Invalid</td> <td>1 amplifier 2 motor function: Valid</td> </tr> <tr> <td>1</td> <td>dflt</td> <td>Default motor: Main</td> <td>Default motor: Sub</td> </tr> <tr> <td>2</td> <td>sftk</td> <td>SF-TK card invalid</td> <td>SF-TK card valid</td> </tr> <tr> <td>3</td> <td></td> <td></td> <td></td> </tr> <tr> <td>4</td> <td></td> <td></td> <td></td> </tr> <tr> <td>5</td> <td></td> <td></td> <td></td> </tr> <tr> <td>6</td> <td></td> <td></td> <td></td> </tr> <tr> <td>7</td> <td></td> <td></td> <td></td> </tr> <tr> <td>8</td> <td></td> <td></td> <td></td> </tr> <tr> <td>9</td> <td></td> <td></td> <td></td> </tr> <tr> <td>A</td> <td></td> <td></td> <td></td> </tr> <tr> <td>B</td> <td></td> <td rowspan="5">This is a fixed control bit.</td> <td rowspan="5"></td> </tr> <tr> <td>C</td> <td>ront</td> </tr> <tr> <td>D</td> <td></td> </tr> <tr> <td>E</td> <td>hzs</td> </tr> <tr> <td>F</td> <td>poff</td> </tr> </tbody> </table>	F	E	D	C	B	A	9	8	poff	hzs		ront					7	6	5	4	3	2	1	0						sftk	dflt	1a2m	bit	Name	Meaning when set to 0	Meaning when set to 1	0	1a2m	1 amplifier 2 motor function: Invalid	1 amplifier 2 motor function: Valid	1	dflt	Default motor: Main	Default motor: Sub	2	sftk	SF-TK card invalid	SF-TK card valid	3				4				5				6				7				8				9				A				B		This is a fixed control bit.		C	ront	D		E	hzs	F	poff	0000 to FFFF HEX setting	0000								
F	E	D	C	B	A	9	8																																																																																																	
poff	hzs		ront																																																																																																					
7	6	5	4	3	2	1	0																																																																																																	
					sftk	dflt	1a2m																																																																																																	
bit	Name	Meaning when set to 0	Meaning when set to 1																																																																																																					
0	1a2m	1 amplifier 2 motor function: Invalid	1 amplifier 2 motor function: Valid																																																																																																					
1	dflt	Default motor: Main	Default motor: Sub																																																																																																					
2	sftk	SF-TK card invalid	SF-TK card valid																																																																																																					
3																																																																																																								
4																																																																																																								
5																																																																																																								
6																																																																																																								
7																																																																																																								
8																																																																																																								
9																																																																																																								
A																																																																																																								
B		This is a fixed control bit.																																																																																																						
C	ront																																																																																																							
D																																																																																																								
E	hzs																																																																																																							
F	poff																																																																																																							
3234	SP034 SFNC2*	<b>For SP/SPH</b>  Spindle function 2  Set the spindle function 2 in bit units.  <table style="width: 100%; text-align: center; border-collapse: collapse;"> <tr> <td style="border: none;">F</td><td style="border: none;">E</td><td style="border: none;">D</td><td style="border: none;">C</td><td style="border: none;">B</td><td style="border: none;">A</td><td style="border: none;">9</td><td style="border: none;">8</td> </tr> <tr> <td style="border: 1px solid black; width: 25px; height: 20px;"></td><td style="border: 1px solid black; width: 25px; height: 20px;"></td><td style="border: 1px solid black; width: 25px; height: 20px;"></td><td style="border: 1px solid black; width: 25px; height: 20px;"></td><td style="border: 1px solid black; width: 25px; height: 20px;"></td><td style="border: 1px solid black; width: 25px; height: 20px;"></td><td style="border: 1px solid black; width: 25px; height: 20px;"></td><td style="border: 1px solid black; width: 25px; height: 20px;"></td> </tr> <tr> <td style="border: none;">7</td><td style="border: none;">6</td><td style="border: none;">5</td><td style="border: none;">4</td><td style="border: none;">3</td><td style="border: none;">2</td><td style="border: none;">1</td><td style="border: none;">0</td> </tr> <tr> <td style="border: 1px solid black; width: 25px; height: 20px;"></td><td style="border: 1px solid black; width: 25px; height: 20px;"></td><td style="border: 1px solid black; width: 25px; height: 20px;"></td><td style="border: 1px solid black; width: 25px; height: 20px;"></td><td style="border: 1px solid black; width: 25px; height: 20px;">mkc2</td><td style="border: 1px solid black; width: 25px; height: 20px;">mkch</td><td style="border: 1px solid black; width: 25px; height: 20px;">invm</td><td style="border: 1px solid black; width: 25px; height: 20px;">mts1</td> </tr> </table> <p><b>(Note)</b> Always set "0" for the empty bits.</p> <table border="1" style="width: 100%; border-collapse: collapse; font-size: 8px;"> <thead> <tr> <th>bit</th> <th>Name</th> <th>Meaning when set to 0</th> <th>Meaning when set to 1</th> </tr> </thead> <tbody> <tr> <td>0</td> <td>mts1</td> <td>Special motor constant invalid</td> <td>Special motor constant setting valid</td> </tr> <tr> <td>1</td> <td>invm</td> <td>A general-purpose motor FV control invalid</td> <td>A general-purpose motor FV control valid</td> </tr> <tr> <td>2</td> <td>mkch</td> <td>Winding switch function invalid</td> <td>Winding switch function valid</td> </tr> <tr> <td>3</td> <td>mkc2</td> <td>This is a fixed control bit.</td> <td></td> </tr> <tr> <td>4</td> <td></td> <td></td> <td></td> </tr> <tr> <td>5</td> <td></td> <td></td> <td></td> </tr> <tr> <td>6</td> <td></td> <td></td> <td></td> </tr> <tr> <td>7</td> <td></td> <td></td> <td></td> </tr> <tr> <td>8</td> <td></td> <td></td> <td></td> </tr> <tr> <td>9</td> <td></td> <td></td> <td></td> </tr> <tr> <td>A</td> <td></td> <td></td> <td></td> </tr> <tr> <td>B</td> <td></td> <td></td> <td></td> </tr> <tr> <td>C</td> <td></td> <td></td> <td></td> </tr> <tr> <td>D</td> <td></td> <td></td> <td></td> </tr> <tr> <td>E</td> <td></td> <td></td> <td></td> </tr> <tr> <td>F</td> <td></td> <td></td> <td></td> </tr> </tbody> </table>	F	E	D	C	B	A	9	8									7	6	5	4	3	2	1	0					mkc2	mkch	invm	mts1	bit	Name	Meaning when set to 0	Meaning when set to 1	0	mts1	Special motor constant invalid	Special motor constant setting valid	1	invm	A general-purpose motor FV control invalid	A general-purpose motor FV control valid	2	mkch	Winding switch function invalid	Winding switch function valid	3	mkc2	This is a fixed control bit.		4				5				6				7				8				9				A				B				C				D				E				F				0000 to FFFF HEX setting	0000
F	E	D	C	B	A	9	8																																																																																																	
7	6	5	4	3	2	1	0																																																																																																	
				mkc2	mkch	invm	mts1																																																																																																	
bit	Name	Meaning when set to 0	Meaning when set to 1																																																																																																					
0	mts1	Special motor constant invalid	Special motor constant setting valid																																																																																																					
1	invm	A general-purpose motor FV control invalid	A general-purpose motor FV control valid																																																																																																					
2	mkch	Winding switch function invalid	Winding switch function valid																																																																																																					
3	mkc2	This is a fixed control bit.																																																																																																						
4																																																																																																								
5																																																																																																								
6																																																																																																								
7																																																																																																								
8																																																																																																								
9																																																																																																								
A																																																																																																								
B																																																																																																								
C																																																																																																								
D																																																																																																								
E																																																																																																								
F																																																																																																								

**4.8 Spindle Parameters**  
**4.8.2 Spindle Parameters**

#	Item	Details	Setting range (unit)	Standard setting																																																																																																				
		<p><b>For SPJ2</b></p> <p>Set the spindle function 2 in bit units.</p> <table style="width: 100%; text-align: center; border-collapse: collapse;"> <tr> <td style="border: none;">F</td><td style="border: none;">E</td><td style="border: none;">D</td><td style="border: none;">C</td><td style="border: none;">B</td><td style="border: none;">A</td><td style="border: none;">9</td><td style="border: none;">8</td> </tr> <tr> <td style="border: 1px solid black; width: 20px; height: 20px;"></td> <td style="border: 1px solid black; width: 20px; height: 20px;"></td> <td style="border: 1px solid black; width: 20px; height: 20px;"></td> <td style="border: 1px solid black; width: 20px; height: 20px;"></td> <td style="border: 1px solid black; width: 20px; height: 20px;"></td> <td style="border: 1px solid black; width: 20px; height: 20px;"></td> <td style="border: 1px solid black; width: 20px; height: 20px;"></td> <td style="border: 1px solid black; width: 20px; height: 20px;"></td> </tr> <tr> <td style="border: none;">7</td><td style="border: none;">6</td><td style="border: none;">5</td><td style="border: none;">4</td><td style="border: none;">3</td><td style="border: none;">2</td><td style="border: none;">1</td><td style="border: none;">0</td> </tr> <tr> <td style="border: 1px solid black; width: 20px; height: 20px;"></td> <td style="border: 1px solid black; width: 20px; height: 20px;"></td> <td style="border: 1px solid black; width: 20px; height: 20px;"></td> <td style="border: 1px solid black; width: 20px; height: 20px;"></td> <td style="border: 1px solid black; width: 20px; height: 20px;"></td> <td style="border: 1px solid black; width: 20px; height: 20px;"></td> <td style="border: 1px solid black; width: 20px; height: 20px;"></td> <td style="border: 1px solid black; width: 20px; height: 20px; text-align: right;">mts1</td> </tr> </table> <p><b>(Note)</b> Always set "0" for the empty bits.</p> <table border="1" style="width: 100%; border-collapse: collapse;"> <thead> <tr> <th style="width: 5%;">bit</th> <th style="width: 10%;">Name</th> <th style="width: 30%;">Meaning when set to 0</th> <th style="width: 30%;">Meaning when set to 1</th> </tr> </thead> <tbody> <tr> <td style="text-align: center;">0</td> <td style="text-align: center;">mts1</td> <td>Special motor constant invalid</td> <td>Special motor constant setting valid</td> </tr> <tr><td style="text-align: center;">1</td><td></td><td></td><td></td></tr> <tr><td style="text-align: center;">2</td><td></td><td></td><td></td></tr> <tr><td style="text-align: center;">3</td><td></td><td></td><td></td></tr> <tr><td style="text-align: center;">4</td><td></td><td></td><td></td></tr> <tr><td style="text-align: center;">5</td><td></td><td></td><td></td></tr> <tr><td style="text-align: center;">6</td><td></td><td></td><td></td></tr> <tr><td style="text-align: center;">7</td><td></td><td></td><td></td></tr> <tr><td style="text-align: center;">8</td><td></td><td></td><td></td></tr> <tr><td style="text-align: center;">9</td><td></td><td></td><td></td></tr> <tr><td style="text-align: center;">A</td><td></td><td></td><td></td></tr> <tr><td style="text-align: center;">B</td><td></td><td></td><td></td></tr> <tr><td style="text-align: center;">C</td><td></td><td></td><td></td></tr> <tr><td style="text-align: center;">D</td><td></td><td></td><td></td></tr> <tr><td style="text-align: center;">E</td><td></td><td></td><td></td></tr> <tr><td style="text-align: center;">F</td><td></td><td></td><td></td></tr> </tbody> </table>	F	E	D	C	B	A	9	8									7	6	5	4	3	2	1	0								mts1	bit	Name	Meaning when set to 0	Meaning when set to 1	0	mts1	Special motor constant invalid	Special motor constant setting valid	1				2				3				4				5				6				7				8				9				A				B				C				D				E				F				0000 to FFFF HEX setting	0000
F	E	D	C	B	A	9	8																																																																																																	
7	6	5	4	3	2	1	0																																																																																																	
							mts1																																																																																																	
bit	Name	Meaning when set to 0	Meaning when set to 1																																																																																																					
0	mts1	Special motor constant invalid	Special motor constant setting valid																																																																																																					
1																																																																																																								
2																																																																																																								
3																																																																																																								
4																																																																																																								
5																																																																																																								
6																																																																																																								
7																																																																																																								
8																																																																																																								
9																																																																																																								
A																																																																																																								
B																																																																																																								
C																																																																																																								
D																																																																																																								
E																																																																																																								
F																																																																																																								
3235	SP035 SFNC3*	<p>Spindle function 3</p> <p><b>For SP/SPH</b></p> <p>Set the spindle function 3 in bit units.</p> <table style="width: 100%; text-align: center; border-collapse: collapse;"> <tr> <td style="border: none;">F</td><td style="border: none;">E</td><td style="border: none;">D</td><td style="border: none;">C</td><td style="border: none;">B</td><td style="border: none;">A</td><td style="border: none;">9</td><td style="border: none;">8</td> </tr> <tr> <td style="border: 1px solid black; width: 20px; height: 20px;"></td> <td style="border: 1px solid black; width: 20px; height: 20px;"></td> <td style="border: 1px solid black; width: 20px; height: 20px;"></td> <td style="border: 1px solid black; width: 20px; height: 20px;"></td> <td style="border: 1px solid black; width: 20px; height: 20px;"></td> <td style="border: 1px solid black; width: 20px; height: 20px;"></td> <td style="border: 1px solid black; width: 20px; height: 20px;"></td> <td style="border: 1px solid black; width: 20px; height: 20px;"></td> </tr> <tr> <td style="border: none;">7</td><td style="border: none;">6</td><td style="border: none;">5</td><td style="border: none;">4</td><td style="border: none;">3</td><td style="border: none;">2</td><td style="border: none;">1</td><td style="border: none;">0</td> </tr> <tr> <td style="border: 1px solid black; width: 20px; height: 20px;"></td> <td style="border: 1px solid black; width: 20px; height: 20px;"></td> <td style="border: 1px solid black; width: 20px; height: 20px;"></td> <td style="border: 1px solid black; width: 20px; height: 20px;"></td> <td style="border: 1px solid black; width: 20px; height: 20px; text-align: center;">lbsd</td> <td style="border: 1px solid black; width: 20px; height: 20px; text-align: center;">hbsd</td> <td style="border: 1px solid black; width: 20px; height: 20px; text-align: center;">lwid</td> <td style="border: 1px solid black; width: 20px; height: 20px; text-align: center;">hwid</td> </tr> </table> <p><b>(Note)</b> Always set "0" for the empty bits.</p> <table border="1" style="width: 100%; border-collapse: collapse;"> <thead> <tr> <th style="width: 5%;">bit</th> <th style="width: 10%;">Name</th> <th style="width: 30%;">Meaning when set to 0</th> <th style="width: 30%;">Meaning when set to 1</th> </tr> </thead> <tbody> <tr> <td style="text-align: center;">0</td> <td style="text-align: center;">hwid</td> <td>H-coil wide-range constant output invalid</td> <td>H-coil wide-range constant output valid</td> </tr> <tr> <td style="text-align: center;">1</td> <td style="text-align: center;">lwid</td> <td>L-coil wide-range constant output invalid</td> <td>L-coil wide-range constant output valid</td> </tr> <tr> <td style="text-align: center;">2</td> <td style="text-align: center;">hbsd</td> <td>H-coil base slide invalid</td> <td>H-coil base slide valid</td> </tr> <tr> <td style="text-align: center;">3</td> <td style="text-align: center;">lbsd</td> <td>L-coil base slide invalid</td> <td>L-coil base slide valid</td> </tr> <tr><td style="text-align: center;">4</td><td></td><td></td><td></td></tr> <tr><td style="text-align: center;">5</td><td></td><td></td><td></td></tr> <tr><td style="text-align: center;">6</td><td></td><td></td><td></td></tr> <tr><td style="text-align: center;">7</td><td></td><td></td><td></td></tr> <tr> <td style="text-align: center;">8</td> <td></td> <td rowspan="8" style="vertical-align: top;">(Used with SPJ.)</td> <td></td> </tr> <tr><td style="text-align: center;">9</td><td></td></tr> <tr><td style="text-align: center;">A</td><td></td></tr> <tr><td style="text-align: center;">B</td><td></td></tr> <tr><td style="text-align: center;">C</td><td></td></tr> <tr><td style="text-align: center;">D</td><td></td></tr> <tr><td style="text-align: center;">E</td><td></td></tr> <tr><td style="text-align: center;">F</td><td></td></tr> </tbody> </table>	F	E	D	C	B	A	9	8									7	6	5	4	3	2	1	0					lbsd	hbsd	lwid	hwid	bit	Name	Meaning when set to 0	Meaning when set to 1	0	hwid	H-coil wide-range constant output invalid	H-coil wide-range constant output valid	1	lwid	L-coil wide-range constant output invalid	L-coil wide-range constant output valid	2	hbsd	H-coil base slide invalid	H-coil base slide valid	3	lbsd	L-coil base slide invalid	L-coil base slide valid	4				5				6				7				8		(Used with SPJ.)		9		A		B		C		D		E		F		0000 to FFFF HEX setting	0000														
F	E	D	C	B	A	9	8																																																																																																	
7	6	5	4	3	2	1	0																																																																																																	
				lbsd	hbsd	lwid	hwid																																																																																																	
bit	Name	Meaning when set to 0	Meaning when set to 1																																																																																																					
0	hwid	H-coil wide-range constant output invalid	H-coil wide-range constant output valid																																																																																																					
1	lwid	L-coil wide-range constant output invalid	L-coil wide-range constant output valid																																																																																																					
2	hbsd	H-coil base slide invalid	H-coil base slide valid																																																																																																					
3	lbsd	L-coil base slide invalid	L-coil base slide valid																																																																																																					
4																																																																																																								
5																																																																																																								
6																																																																																																								
7																																																																																																								
8		(Used with SPJ.)																																																																																																						
9																																																																																																								
A																																																																																																								
B																																																																																																								
C																																																																																																								
D																																																																																																								
E																																																																																																								
F																																																																																																								

**4.8 Spindle Parameters**  
**4.8.2 Spindle Parameters**

#	Item	Details	Setting range (unit)	Standard setting																																																																																																				
		<p><b>For SPJ2</b></p> <p>Set the spindle function 3 in bit units.</p> <table border="1" style="width:100%; text-align:center;"> <tr> <td>F</td><td>E</td><td>D</td><td>C</td><td>B</td><td>A</td><td>9</td><td>8</td> </tr> <tr> <td> </td><td> </td><td> </td><td> </td><td> </td><td> </td><td> </td><td> </td> </tr> <tr> <td>7</td><td>6</td><td>5</td><td>4</td><td>3</td><td>2</td><td>1</td><td>0</td> </tr> <tr> <td> </td><td> </td><td> </td><td> </td><td> </td><td>hbsd</td><td> </td><td>hwid</td> </tr> </table> <p><b>(Note)</b> Always set "0" for the empty bits.</p> <table border="1" style="width:100%; text-align:center;"> <thead> <tr> <th>bit</th> <th>Name</th> <th>Meaning when set to 0</th> <th>Meaning when set to 1</th> </tr> </thead> <tbody> <tr> <td>0</td> <td>hwid</td> <td>H-coil wide-range constant output invalid</td> <td>H-coil wide-range constant output valid</td> </tr> <tr> <td>1</td> <td> </td> <td> </td> <td> </td> </tr> <tr> <td>2</td> <td>hbsd</td> <td>H-coil base slide invalid</td> <td>H-coil base slide valid</td> </tr> <tr> <td>3</td> <td> </td> <td> </td> <td> </td> </tr> <tr> <td>4</td> <td> </td> <td> </td> <td> </td> </tr> <tr> <td>5</td> <td> </td> <td> </td> <td> </td> </tr> <tr> <td>6</td> <td> </td> <td> </td> <td> </td> </tr> <tr> <td>7</td> <td> </td> <td> </td> <td> </td> </tr> <tr> <td>8</td> <td> </td> <td> </td> <td> </td> </tr> <tr> <td>9</td> <td> </td> <td> </td> <td> </td> </tr> <tr> <td>A</td> <td> </td> <td> </td> <td> </td> </tr> <tr> <td>B</td> <td> </td> <td> </td> <td> </td> </tr> <tr> <td>C</td> <td> </td> <td> </td> <td> </td> </tr> <tr> <td>D</td> <td> </td> <td> </td> <td> </td> </tr> <tr> <td>E</td> <td> </td> <td> </td> <td> </td> </tr> <tr> <td>F</td> <td> </td> <td> </td> <td> </td> </tr> </tbody> </table>	F	E	D	C	B	A	9	8									7	6	5	4	3	2	1	0						hbsd		hwid	bit	Name	Meaning when set to 0	Meaning when set to 1	0	hwid	H-coil wide-range constant output invalid	H-coil wide-range constant output valid	1				2	hbsd	H-coil base slide invalid	H-coil base slide valid	3				4				5				6				7				8				9				A				B				C				D				E				F				0000 to FFFF HEX setting	0000
F	E	D	C	B	A	9	8																																																																																																	
7	6	5	4	3	2	1	0																																																																																																	
					hbsd		hwid																																																																																																	
bit	Name	Meaning when set to 0	Meaning when set to 1																																																																																																					
0	hwid	H-coil wide-range constant output invalid	H-coil wide-range constant output valid																																																																																																					
1																																																																																																								
2	hbsd	H-coil base slide invalid	H-coil base slide valid																																																																																																					
3																																																																																																								
4																																																																																																								
5																																																																																																								
6																																																																																																								
7																																																																																																								
8																																																																																																								
9																																																																																																								
A																																																																																																								
B																																																																																																								
C																																																																																																								
D																																																																																																								
E																																																																																																								
F																																																																																																								
3236	SP036 SFNC4* Spindle function 4	<p>Set the spindle function 4 in bit units.</p> <table border="1" style="width:100%; text-align:center;"> <tr> <td>F</td><td>E</td><td>D</td><td>C</td><td>B</td><td>A</td><td>9</td><td>8</td> </tr> <tr> <td> </td><td> </td><td> </td><td> </td><td> </td><td> </td><td>dslm</td><td>dssm</td> </tr> <tr> <td>7</td><td>6</td><td>5</td><td>4</td><td>3</td><td>2</td><td>1</td><td>0</td> </tr> <tr> <td> </td><td> </td><td>enc2</td><td>enc1</td><td>mag2</td><td>mag1</td><td>plg2</td><td>plg1</td> </tr> </table> <p><b>(Note)</b> Always set "0" for the empty bits.</p> <table border="1" style="width:100%; text-align:center;"> <thead> <tr> <th>bit</th> <th>Name</th> <th>Meaning when set to 0</th> <th>Meaning when set to 1</th> </tr> </thead> <tbody> <tr> <td>0</td> <td>plg1</td> <td>PLG of motor 1 valid</td> <td>PLG of motor 1 invalid</td> </tr> <tr> <td>1</td> <td>plg2</td> <td>PLG of motor 2 valid</td> <td>PLG of motor 2 invalid</td> </tr> <tr> <td>2</td> <td>mag1</td> <td>MAG of motor 1 valid</td> <td>MAG of motor 1 invalid</td> </tr> <tr> <td>3</td> <td>mag2</td> <td>MAG of motor 2 valid</td> <td>MAG of motor 2 invalid</td> </tr> <tr> <td>4</td> <td>enc1</td> <td>ENC of motor 1 valid</td> <td>ENC of motor 1 invalid</td> </tr> <tr> <td>5</td> <td>enc2</td> <td>ENC of motor 2 valid</td> <td>ENC of motor 2 invalid</td> </tr> <tr> <td>6</td> <td> </td> <td> </td> <td> </td> </tr> <tr> <td>7</td> <td> </td> <td> </td> <td> </td> </tr> <tr> <td>8</td> <td>dssm</td> <td>Speedometer output valid</td> <td>Speedometer output invalid</td> </tr> <tr> <td>9</td> <td>dslm</td> <td>Load meter output valid</td> <td>Load meter output invalid</td> </tr> <tr> <td>A</td> <td> </td> <td> </td> <td> </td> </tr> <tr> <td>B</td> <td> </td> <td> </td> <td> </td> </tr> <tr> <td>C</td> <td> </td> <td> </td> <td> </td> </tr> <tr> <td>D</td> <td> </td> <td> </td> <td> </td> </tr> <tr> <td>E</td> <td> </td> <td> </td> <td> </td> </tr> <tr> <td>F</td> <td> </td> <td> </td> <td> </td> </tr> </tbody> </table>	F	E	D	C	B	A	9	8							dslm	dssm	7	6	5	4	3	2	1	0			enc2	enc1	mag2	mag1	plg2	plg1	bit	Name	Meaning when set to 0	Meaning when set to 1	0	plg1	PLG of motor 1 valid	PLG of motor 1 invalid	1	plg2	PLG of motor 2 valid	PLG of motor 2 invalid	2	mag1	MAG of motor 1 valid	MAG of motor 1 invalid	3	mag2	MAG of motor 2 valid	MAG of motor 2 invalid	4	enc1	ENC of motor 1 valid	ENC of motor 1 invalid	5	enc2	ENC of motor 2 valid	ENC of motor 2 invalid	6				7				8	dssm	Speedometer output valid	Speedometer output invalid	9	dslm	Load meter output valid	Load meter output invalid	A				B				C				D				E				F				0000 to FFFF HEX setting	0000
F	E	D	C	B	A	9	8																																																																																																	
						dslm	dssm																																																																																																	
7	6	5	4	3	2	1	0																																																																																																	
		enc2	enc1	mag2	mag1	plg2	plg1																																																																																																	
bit	Name	Meaning when set to 0	Meaning when set to 1																																																																																																					
0	plg1	PLG of motor 1 valid	PLG of motor 1 invalid																																																																																																					
1	plg2	PLG of motor 2 valid	PLG of motor 2 invalid																																																																																																					
2	mag1	MAG of motor 1 valid	MAG of motor 1 invalid																																																																																																					
3	mag2	MAG of motor 2 valid	MAG of motor 2 invalid																																																																																																					
4	enc1	ENC of motor 1 valid	ENC of motor 1 invalid																																																																																																					
5	enc2	ENC of motor 2 valid	ENC of motor 2 invalid																																																																																																					
6																																																																																																								
7																																																																																																								
8	dssm	Speedometer output valid	Speedometer output invalid																																																																																																					
9	dslm	Load meter output valid	Load meter output invalid																																																																																																					
A																																																																																																								
B																																																																																																								
C																																																																																																								
D																																																																																																								
E																																																																																																								
F																																																																																																								



**4.8 Spindle Parameters**  
**4.8.2 Spindle Parameters**

#	Item	Details	Setting range (unit)	Standard setting																																																																																																				
3237	SP037 SFNC5*	Spindle function 5 <b>For SP/SPH</b> Set the spindle function 5 in bit units. <table style="width: 100%; text-align: center; border-collapse: collapse;"> <tr> <td style="border: none;">F</td><td style="border: none;">E</td><td style="border: none;">D</td><td style="border: none;">C</td><td style="border: none;">B</td><td style="border: none;">A</td><td style="border: none;">9</td><td style="border: none;">8</td> </tr> <tr> <td style="border: 1px solid black; width: 20px;">splg</td><td style="border: 1px solid black; width: 20px;">dplg</td><td style="border: 1px solid black; width: 20px;"></td><td style="border: 1px solid black; width: 20px;"></td><td style="border: 1px solid black; width: 20px;"></td><td style="border: 1px solid black; width: 20px;">noplg</td><td style="border: 1px solid black; width: 20px;">nsno</td><td style="border: 1px solid black; width: 20px;">nosg</td> </tr> <tr> <td style="border: none;">7</td><td style="border: none;">6</td><td style="border: none;">5</td><td style="border: none;">4</td><td style="border: none;">3</td><td style="border: none;">2</td><td style="border: none;">1</td><td style="border: none;">0</td> </tr> <tr> <td style="border: 1px solid black; width: 20px;"></td><td style="border: 1px solid black; width: 20px;"></td><td style="border: 1px solid black; width: 20px;"></td><td style="border: 1px solid black; width: 20px;"></td><td style="border: 1px solid black; width: 20px;"></td><td style="border: 1px solid black; width: 20px;">plgo</td><td style="border: 1px solid black; width: 20px;">mago</td><td style="border: 1px solid black; width: 20px;">enco</td> </tr> </table> <p><b>(Note)</b> Always set "0" for the empty bits.</p> <table border="1" style="width: 100%; border-collapse: collapse; text-align: center;"> <thead> <tr> <th style="width: 5%;">bit</th> <th style="width: 10%;">Name</th> <th style="width: 30%;">Meaning when set to 0</th> <th style="width: 30%;">Meaning when set to 1</th> </tr> </thead> <tbody> <tr> <td>0</td> <td>enco</td> <td>Encoder orientation invalid</td> <td>Encoder orientation valid</td> </tr> <tr> <td>1</td> <td>mago</td> <td>Magnet detector orientation invalid</td> <td>Magnet detector orientation valid</td> </tr> <tr> <td>2</td> <td>plgo</td> <td>PLG orientation invalid</td> <td>PLG orientation valid</td> </tr> <tr> <td>3</td> <td></td> <td></td> <td></td> </tr> <tr> <td>4</td> <td></td> <td></td> <td></td> </tr> <tr> <td>5</td> <td></td> <td></td> <td></td> </tr> <tr> <td>6</td> <td></td> <td></td> <td></td> </tr> <tr> <td>7</td> <td></td> <td></td> <td></td> </tr> <tr> <td>8</td> <td>nosg</td> <td>No-signal detection type (Always monitoring)</td> <td>Monitoring only in position loop or orientation-mode</td> </tr> <tr> <td>9</td> <td>nsno</td> <td>Fixed control bit</td> <td></td> </tr> <tr> <td>A</td> <td>noplg</td> <td>Fixed control bit</td> <td></td> </tr> <tr> <td>B</td> <td></td> <td></td> <td></td> </tr> <tr> <td>C</td> <td></td> <td></td> <td></td> </tr> <tr> <td>D</td> <td></td> <td></td> <td></td> </tr> <tr> <td>E</td> <td>dplg</td> <td>Fixed control bit</td> <td></td> </tr> <tr> <td>F</td> <td>splg</td> <td>Fixed control bit</td> <td></td> </tr> </tbody> </table> <p><b>(Note)</b> For bit0 to 2, do not set to "1" in two or more bits at the same time.</p>	F	E	D	C	B	A	9	8	splg	dplg				noplg	nsno	nosg	7	6	5	4	3	2	1	0						plgo	mago	enco	bit	Name	Meaning when set to 0	Meaning when set to 1	0	enco	Encoder orientation invalid	Encoder orientation valid	1	mago	Magnet detector orientation invalid	Magnet detector orientation valid	2	plgo	PLG orientation invalid	PLG orientation valid	3				4				5				6				7				8	nosg	No-signal detection type (Always monitoring)	Monitoring only in position loop or orientation-mode	9	nsno	Fixed control bit		A	noplg	Fixed control bit		B				C				D				E	dplg	Fixed control bit		F	splg	Fixed control bit		0000 to FFFF HEX setting	0000
		F	E	D	C	B	A	9	8																																																																																															
splg	dplg				noplg	nsno	nosg																																																																																																	
7	6	5	4	3	2	1	0																																																																																																	
					plgo	mago	enco																																																																																																	
bit	Name	Meaning when set to 0	Meaning when set to 1																																																																																																					
0	enco	Encoder orientation invalid	Encoder orientation valid																																																																																																					
1	mago	Magnet detector orientation invalid	Magnet detector orientation valid																																																																																																					
2	plgo	PLG orientation invalid	PLG orientation valid																																																																																																					
3																																																																																																								
4																																																																																																								
5																																																																																																								
6																																																																																																								
7																																																																																																								
8	nosg	No-signal detection type (Always monitoring)	Monitoring only in position loop or orientation-mode																																																																																																					
9	nsno	Fixed control bit																																																																																																						
A	noplg	Fixed control bit																																																																																																						
B																																																																																																								
C																																																																																																								
D																																																																																																								
E	dplg	Fixed control bit																																																																																																						
F	splg	Fixed control bit																																																																																																						
		<b>For SPJ2</b> Set the spindle function 5 in bit units. <table style="width: 100%; text-align: center; border-collapse: collapse;"> <tr> <td style="border: none;">F</td><td style="border: none;">E</td><td style="border: none;">D</td><td style="border: none;">C</td><td style="border: none;">B</td><td style="border: none;">A</td><td style="border: none;">9</td><td style="border: none;">8</td> </tr> <tr> <td style="border: 1px solid black; width: 20px;"></td><td style="border: 1px solid black; width: 20px;"></td><td style="border: 1px solid black; width: 20px;"></td><td style="border: 1px solid black; width: 20px;"></td><td style="border: 1px solid black; width: 20px;"></td><td style="border: 1px solid black; width: 20px;"></td><td style="border: 1px solid black; width: 20px;"></td><td style="border: 1px solid black; width: 20px;">nstv</td> </tr> <tr> <td style="border: none;">7</td><td style="border: none;">6</td><td style="border: none;">5</td><td style="border: none;">4</td><td style="border: none;">3</td><td style="border: none;">2</td><td style="border: none;">1</td><td style="border: none;">0</td> </tr> <tr> <td style="border: 1px solid black; width: 20px;"></td><td style="border: 1px solid black; width: 20px;"></td><td style="border: 1px solid black; width: 20px;"></td><td style="border: 1px solid black; width: 20px;"></td><td style="border: 1px solid black; width: 20px;"></td><td style="border: 1px solid black; width: 20px;">plgo</td><td style="border: 1px solid black; width: 20px;"></td><td style="border: 1px solid black; width: 20px;">enco</td> </tr> </table> <p><b>(Note)</b> Always set "0" for the empty bits.</p> <table border="1" style="width: 100%; border-collapse: collapse; text-align: center;"> <thead> <tr> <th style="width: 5%;">bit</th> <th style="width: 10%;">Name</th> <th style="width: 30%;">Meaning when set to 0</th> <th style="width: 30%;">Meaning when set to 1</th> </tr> </thead> <tbody> <tr> <td>0</td> <td>enco</td> <td>Encoder orientation invalid</td> <td>Encoder orientation valid</td> </tr> <tr> <td>1</td> <td></td> <td></td> <td></td> </tr> <tr> <td>2</td> <td>plgo</td> <td>PLG orientation invalid</td> <td>PLG orientation valid</td> </tr> <tr> <td>3</td> <td></td> <td></td> <td></td> </tr> <tr> <td>4</td> <td></td> <td></td> <td></td> </tr> <tr> <td>5</td> <td></td> <td></td> <td></td> </tr> <tr> <td>6</td> <td></td> <td></td> <td></td> </tr> <tr> <td>7</td> <td></td> <td></td> <td></td> </tr> <tr> <td>8</td> <td>nstv</td> <td>No-signal detection type (Always monitoring)</td> <td>Monitoring only in position loop or orientation mode</td> </tr> <tr> <td>9</td> <td></td> <td></td> <td></td> </tr> <tr> <td>A</td> <td></td> <td></td> <td></td> </tr> <tr> <td>B</td> <td></td> <td></td> <td></td> </tr> <tr> <td>C</td> <td></td> <td></td> <td></td> </tr> <tr> <td>D</td> <td></td> <td></td> <td></td> </tr> <tr> <td>E</td> <td></td> <td></td> <td></td> </tr> <tr> <td>F</td> <td></td> <td></td> <td></td> </tr> </tbody> </table>	F	E	D	C	B	A	9	8								nstv	7	6	5	4	3	2	1	0						plgo		enco	bit	Name	Meaning when set to 0	Meaning when set to 1	0	enco	Encoder orientation invalid	Encoder orientation valid	1				2	plgo	PLG orientation invalid	PLG orientation valid	3				4				5				6				7				8	nstv	No-signal detection type (Always monitoring)	Monitoring only in position loop or orientation mode	9				A				B				C				D				E				F				0000 to FFFF HEX setting	0000
F	E	D	C	B	A	9	8																																																																																																	
							nstv																																																																																																	
7	6	5	4	3	2	1	0																																																																																																	
					plgo		enco																																																																																																	
bit	Name	Meaning when set to 0	Meaning when set to 1																																																																																																					
0	enco	Encoder orientation invalid	Encoder orientation valid																																																																																																					
1																																																																																																								
2	plgo	PLG orientation invalid	PLG orientation valid																																																																																																					
3																																																																																																								
4																																																																																																								
5																																																																																																								
6																																																																																																								
7																																																																																																								
8	nstv	No-signal detection type (Always monitoring)	Monitoring only in position loop or orientation mode																																																																																																					
9																																																																																																								
A																																																																																																								
B																																																																																																								
C																																																																																																								
D																																																																																																								
E																																																																																																								
F																																																																																																								

## 4.8 Spindle Parameters

### 4.8.2 Spindle Parameters

#	Item	Details	Setting range (unit)	Standard setting																																																																																																												
3238	SP038 SFNC6*	Spindle function 6 <b>For SP/SPH</b> Set the spindle function 6 in bit units. <table style="width: 100%; text-align: center; border-collapse: collapse;"> <tr> <td>F</td><td>E</td><td>D</td><td>C</td><td>B</td><td>A</td><td>9</td><td>8</td> </tr> <tr> <td>opl</td><td>lmx</td><td>iqsv</td><td>XFzs</td><td>dcsn</td><td>lmp</td><td>pl80</td><td>sdt2</td> </tr> <tr><td colspan="8"> </td></tr> <tr> <td>7</td><td>6</td><td>5</td><td>4</td><td>3</td><td>2</td><td>1</td><td>0</td> </tr> <tr> <td>vfbs</td><td>orm</td><td>adin</td><td>tdn</td><td>plg2</td><td>pftm</td><td></td><td>alty</td> </tr> </table> <p><b>(Note)</b> Always set "0" for the empty bits.</p> <table border="1" style="width: 100%; border-collapse: collapse;"> <thead> <tr> <th>bit</th> <th>Name</th> <th>Meaning when set to 0</th> <th>Meaning when set to 1</th> </tr> </thead> <tbody> <tr> <td>0</td> <td>alty</td> <td>Deceleration stop during special alarm invalid</td> <td>Deceleration stop during special alarm valid</td> </tr> <tr> <td>1</td> <td></td> <td></td> <td></td> </tr> <tr> <td>2</td> <td>pftm</td> <td>Encoder feedback serial communication invalid</td> <td>Encoder feedback serial communication valid</td> </tr> <tr> <td>3</td> <td>plg2</td> <td>Semi-closed pulse output signal x2 invalid</td> <td>Semi-closed pulse output signal x2 valid</td> </tr> <tr> <td>4</td> <td>tdn</td> <td rowspan="7">Fixed control bit</td> <td rowspan="7"></td> </tr> <tr> <td>5</td> <td>adin</td> </tr> <tr> <td>6</td> <td>orm</td> <td>Orientation start memo invalid</td> <td>Orientation start memo valid</td> </tr> <tr> <td>7</td> <td>vfbs</td> </tr> <tr> <td>8</td> <td>sdt2</td> </tr> <tr> <td>9</td> <td>pl80</td> </tr> <tr> <td>A</td> <td>lmp</td> </tr> <tr> <td>B</td> <td>dcsn</td> <td rowspan="4">Fixed control bit</td> <td rowspan="4"></td> </tr> <tr> <td>C</td> <td>XFzs</td> </tr> <tr> <td>D</td> <td>iqsv</td> </tr> <tr> <td>E</td> <td>lmx</td> </tr> <tr> <td>F</td> <td>opl</td> <td>Open loop operation invalid</td> <td>Open loop operation valid</td> </tr> </tbody> </table>	F	E	D	C	B	A	9	8	opl	lmx	iqsv	XFzs	dcsn	lmp	pl80	sdt2									7	6	5	4	3	2	1	0	vfbs	orm	adin	tdn	plg2	pftm		alty	bit	Name	Meaning when set to 0	Meaning when set to 1	0	alty	Deceleration stop during special alarm invalid	Deceleration stop during special alarm valid	1				2	pftm	Encoder feedback serial communication invalid	Encoder feedback serial communication valid	3	plg2	Semi-closed pulse output signal x2 invalid	Semi-closed pulse output signal x2 valid	4	tdn	Fixed control bit		5	adin	6	orm	Orientation start memo invalid	Orientation start memo valid	7	vfbs	8	sdt2	9	pl80	A	lmp	B	dcsn	Fixed control bit		C	XFzs	D	iqsv	E	lmx	F	opl	Open loop operation invalid	Open loop operation valid	0000 to FFFF HEX setting	0000																
		F	E	D	C	B	A	9	8																																																																																																							
opl	lmx	iqsv	XFzs	dcsn	lmp	pl80	sdt2																																																																																																									
7	6	5	4	3	2	1	0																																																																																																									
vfbs	orm	adin	tdn	plg2	pftm		alty																																																																																																									
bit	Name	Meaning when set to 0	Meaning when set to 1																																																																																																													
0	alty	Deceleration stop during special alarm invalid	Deceleration stop during special alarm valid																																																																																																													
1																																																																																																																
2	pftm	Encoder feedback serial communication invalid	Encoder feedback serial communication valid																																																																																																													
3	plg2	Semi-closed pulse output signal x2 invalid	Semi-closed pulse output signal x2 valid																																																																																																													
4	tdn	Fixed control bit																																																																																																														
5	adin																																																																																																															
6	orm			Orientation start memo invalid	Orientation start memo valid																																																																																																											
7	vfbs																																																																																																															
8	sdt2																																																																																																															
9	pl80																																																																																																															
A	lmp																																																																																																															
B	dcsn	Fixed control bit																																																																																																														
C	XFzs																																																																																																															
D	iqsv																																																																																																															
E	lmx																																																																																																															
F	opl	Open loop operation invalid	Open loop operation valid																																																																																																													
		<b>For SPJ2</b> Set the spindle function 6 in bit units. <table style="width: 100%; text-align: center; border-collapse: collapse;"> <tr> <td>F</td><td>E</td><td>D</td><td>C</td><td>B</td><td>A</td><td>9</td><td>8</td> </tr> <tr> <td></td><td></td><td></td><td></td><td></td><td></td><td></td><td></td> </tr> <tr><td colspan="8"> </td></tr> <tr> <td>7</td><td>6</td><td>5</td><td>4</td><td>3</td><td>2</td><td>1</td><td>0</td> </tr> <tr> <td></td><td></td><td></td><td></td><td></td><td>pftm</td><td></td><td>alty</td> </tr> </table> <p><b>(Note)</b> Always set "0" for the empty bits.</p> <table border="1" style="width: 100%; border-collapse: collapse;"> <thead> <tr> <th>bit</th> <th>Name</th> <th>Meaning when set to 0</th> <th>Meaning when set to 1</th> </tr> </thead> <tbody> <tr> <td>0</td> <td>alty</td> <td>Deceleration stop during special alarm invalid</td> <td>Deceleration stop during special alarm valid</td> </tr> <tr> <td>1</td> <td></td> <td></td> <td></td> </tr> <tr> <td>2</td> <td>pftm</td> <td>Thread cutting position data invalid</td> <td>Thread cutting position data valid</td> </tr> <tr> <td>3</td> <td></td> <td></td> <td></td> </tr> <tr> <td>4</td> <td></td> <td></td> <td></td> </tr> <tr> <td>5</td> <td></td> <td></td> <td></td> </tr> <tr> <td>6</td> <td></td> <td></td> <td></td> </tr> <tr> <td>7</td> <td></td> <td></td> <td></td> </tr> <tr> <td>8</td> <td></td> <td></td> <td></td> </tr> <tr> <td>9</td> <td></td> <td></td> <td></td> </tr> <tr> <td>A</td> <td></td> <td></td> <td></td> </tr> <tr> <td>B</td> <td></td> <td></td> <td></td> </tr> <tr> <td>C</td> <td></td> <td></td> <td></td> </tr> <tr> <td>D</td> <td></td> <td></td> <td></td> </tr> <tr> <td>E</td> <td></td> <td></td> <td></td> </tr> <tr> <td>F</td> <td>opl</td> <td>Open loop operation invalid</td> <td>Open loop operation valid</td> </tr> </tbody> </table>	F	E	D	C	B	A	9	8																	7	6	5	4	3	2	1	0						pftm		alty	bit	Name	Meaning when set to 0	Meaning when set to 1	0	alty	Deceleration stop during special alarm invalid	Deceleration stop during special alarm valid	1				2	pftm	Thread cutting position data invalid	Thread cutting position data valid	3				4				5				6				7				8				9				A				B				C				D				E				F	opl	Open loop operation invalid	Open loop operation valid	0000 to FFFF HEX setting	0000
F	E	D	C	B	A	9	8																																																																																																									
7	6	5	4	3	2	1	0																																																																																																									
					pftm		alty																																																																																																									
bit	Name	Meaning when set to 0	Meaning when set to 1																																																																																																													
0	alty	Deceleration stop during special alarm invalid	Deceleration stop during special alarm valid																																																																																																													
1																																																																																																																
2	pftm	Thread cutting position data invalid	Thread cutting position data valid																																																																																																													
3																																																																																																																
4																																																																																																																
5																																																																																																																
6																																																																																																																
7																																																																																																																
8																																																																																																																
9																																																																																																																
A																																																																																																																
B																																																																																																																
C																																																																																																																
D																																																																																																																
E																																																																																																																
F	opl	Open loop operation invalid	Open loop operation valid																																																																																																													

**4.8 Spindle Parameters**  
**4.8.2 Spindle Parameters**

#	Item	Details	Setting range (unit)	Standard setting																																
3239	SP039 ATYP*	Amplifier type	0000 to FFFF HEX setting	0000																																
		<p><b>For SP/SPH</b></p> <p>Set the amplifier type. Set each amplifier type or "0". This parameter corresponds to MDS-A-SP (version A2 or above) and MDS-B-SP.</p> <table border="1" style="width: 100%; border-collapse: collapse;"> <thead> <tr> <th style="text-align: center;">Parameter setting</th> <th style="text-align: center;">Amplifier type</th> </tr> </thead> <tbody> <tr><td style="text-align: center;">0000</td><td style="text-align: center;">—</td></tr> <tr><td style="text-align: center;">0001</td><td style="text-align: center;">SP – 075</td></tr> <tr><td style="text-align: center;">0002</td><td style="text-align: center;">SP – 15</td></tr> <tr><td style="text-align: center;">0003</td><td style="text-align: center;">SP – 22</td></tr> <tr><td style="text-align: center;">0004</td><td style="text-align: center;">SP – 37</td></tr> <tr><td style="text-align: center;">0005</td><td style="text-align: center;">SP – 55</td></tr> <tr><td style="text-align: center;">0006</td><td style="text-align: center;">SP – 75</td></tr> <tr><td style="text-align: center;">0007</td><td style="text-align: center;">SP – 110</td></tr> <tr><td style="text-align: center;">0008</td><td style="text-align: center;">SP – 150</td></tr> <tr><td style="text-align: center;">0009</td><td style="text-align: center;">SP – 185</td></tr> <tr><td style="text-align: center;">000A</td><td style="text-align: center;">SP – 220</td></tr> <tr><td style="text-align: center;">000B</td><td style="text-align: center;">SP – 260</td></tr> <tr><td style="text-align: center;">000C</td><td style="text-align: center;">SP – 300</td></tr> <tr><td style="text-align: center;">000D</td><td style="text-align: center;">CSP – 370</td></tr> <tr><td style="text-align: center;">000E</td><td style="text-align: center;">CSP – 450</td></tr> <tr><td style="text-align: center;">000F</td><td style="text-align: center;">SP – 04</td></tr> <tr><td style="text-align: center;">0010</td><td style="text-align: center;">SP – 550</td></tr> </tbody> </table>			Parameter setting	Amplifier type	0000	—	0001	SP – 075	0002	SP – 15	0003	SP – 22	0004	SP – 37	0005	SP – 55	0006	SP – 75	0007	SP – 110	0008	SP – 150	0009	SP – 185	000A	SP – 220	000B	SP – 260	000C	SP – 300	000D	CSP – 370	000E	CSP – 450
Parameter setting	Amplifier type																																			
0000	—																																			
0001	SP – 075																																			
0002	SP – 15																																			
0003	SP – 22																																			
0004	SP – 37																																			
0005	SP – 55																																			
0006	SP – 75																																			
0007	SP – 110																																			
0008	SP – 150																																			
0009	SP – 185																																			
000A	SP – 220																																			
000B	SP – 260																																			
000C	SP – 300																																			
000D	CSP – 370																																			
000E	CSP – 450																																			
000F	SP – 04																																			
0010	SP – 550																																			
		<p><b>For SPJ2</b></p> <p>Set the amplifier type. Set each amplifier type or "0". This parameter corresponds to MDS-B-SPJ2.</p> <table border="1" style="width: 100%; border-collapse: collapse;"> <thead> <tr> <th style="text-align: center;">Parameter setting</th> <th style="text-align: center;">Amplifier type</th> </tr> </thead> <tbody> <tr><td style="text-align: center;">0000</td><td style="text-align: center;">—</td></tr> <tr><td style="text-align: center;">0001</td><td style="text-align: center;">SPJ2 – 02</td></tr> <tr><td style="text-align: center;">0002</td><td style="text-align: center;">SPJ2 – 04</td></tr> <tr><td style="text-align: center;">0003</td><td style="text-align: center;">SPJ2 – 075</td></tr> <tr><td style="text-align: center;">0004</td><td style="text-align: center;">SPJ2 – 15</td></tr> <tr><td style="text-align: center;">0005</td><td style="text-align: center;">SPJ2 – 22</td></tr> <tr><td style="text-align: center;">0006</td><td style="text-align: center;">SPJ2 – 37</td></tr> <tr><td style="text-align: center;">0007</td><td style="text-align: center;">SPJ2 – 55</td></tr> <tr><td style="text-align: center;">0008</td><td style="text-align: center;">SPJ2 – 75</td></tr> <tr><td style="text-align: center;">0009</td><td style="text-align: center;">SPJ2 – 110/110C</td></tr> </tbody> </table>	Parameter setting	Amplifier type	0000	—	0001	SPJ2 – 02	0002	SPJ2 – 04	0003	SPJ2 – 075	0004	SPJ2 – 15	0005	SPJ2 – 22	0006	SPJ2 – 37	0007	SPJ2 – 55	0008	SPJ2 – 75	0009	SPJ2 – 110/110C	0000 to FFFF HEX setting	0000										
Parameter setting	Amplifier type																																			
0000	—																																			
0001	SPJ2 – 02																																			
0002	SPJ2 – 04																																			
0003	SPJ2 – 075																																			
0004	SPJ2 – 15																																			
0005	SPJ2 – 22																																			
0006	SPJ2 – 37																																			
0007	SPJ2 – 55																																			
0008	SPJ2 – 75																																			
0009	SPJ2 – 110/110C																																			

**4.8 Spindle Parameters**  
**4.8.2 Spindle Parameters**

#	Item	Details	Setting range (unit)	Standard setting																																																																																																																																				
3240	SP040	MTYP* Motor type	0000 to FFFF HEX setting	0000																																																																																																																																				
		<p><b>For SP/SPH</b></p> <p>This parameter is valid when SP034 (SFNC2) bit0 is set to "0".            Set the appropriate motor number by selecting it from the standard motors listed below.</p> <table border="1" style="width: 100%; border-collapse: collapse;"> <thead> <tr> <th style="text-align: center;">Parameter setting</th> <th style="text-align: center;">Motor type</th> <th style="text-align: center;">Maximum speed</th> <th style="text-align: center;">Corresponding amplifier</th> </tr> </thead> <tbody> <tr><td style="text-align: center;">0000</td><td></td><td></td><td></td></tr> <tr><td style="text-align: center;">0001</td><td style="text-align: center;">SJ – 2.2A</td><td style="text-align: center;">10000 r/min</td><td style="text-align: center;">SP – 22</td></tr> <tr><td style="text-align: center;">0002</td><td style="text-align: center;">SJ – 3.7A</td><td style="text-align: center;">10000 r/min</td><td style="text-align: center;">SP – 37</td></tr> <tr><td style="text-align: center;">0003</td><td style="text-align: center;">SJ – 5.5A</td><td style="text-align: center;">8000 r/min</td><td style="text-align: center;">SP – 55</td></tr> <tr><td style="text-align: center;">0004</td><td style="text-align: center;">SJ – 7.5A</td><td style="text-align: center;">8000 r/min</td><td style="text-align: center;">SP – 75</td></tr> <tr><td style="text-align: center;">0005</td><td style="text-align: center;">SJ – 11A</td><td style="text-align: center;">6000 r/min</td><td style="text-align: center;">SP – 110</td></tr> <tr><td style="text-align: center;">0006</td><td style="text-align: center;">SJ – 15A</td><td style="text-align: center;">6000 r/min</td><td style="text-align: center;">SP – 150</td></tr> <tr><td style="text-align: center;">0007</td><td style="text-align: center;">SJ – 18.5A</td><td style="text-align: center;">6000 r/min</td><td style="text-align: center;">SP – 185</td></tr> <tr><td style="text-align: center;">0008</td><td style="text-align: center;">SJ – 22A</td><td style="text-align: center;">4500 r/min</td><td style="text-align: center;">SP – 220</td></tr> <tr><td style="text-align: center;">0009</td><td style="text-align: center;">SJ – 26A</td><td style="text-align: center;">4500 r/min</td><td style="text-align: center;">SP – 260</td></tr> <tr><td style="text-align: center;">000A</td><td style="text-align: center;">SJ – 30A</td><td style="text-align: center;">4500 r/min</td><td style="text-align: center;">SP – 300</td></tr> <tr><td style="text-align: center;">000B</td><td></td><td></td><td></td></tr> <tr><td style="text-align: center;">000C</td><td></td><td></td><td></td></tr> <tr><td style="text-align: center;">000D</td><td></td><td></td><td></td></tr> <tr><td style="text-align: center;">000E</td><td></td><td></td><td></td></tr> <tr><td style="text-align: center;">000F</td><td></td><td></td><td></td></tr> <tr><td style="text-align: center;">0010</td><td></td><td></td><td></td></tr> <tr><td style="text-align: center;">0011</td><td style="text-align: center;">SJ – N0.75A</td><td style="text-align: center;">10000 r/min</td><td style="text-align: center;">SP – 075</td></tr> <tr><td style="text-align: center;">0012</td><td style="text-align: center;">SJ – N1.5A</td><td style="text-align: center;">10000 r/min</td><td style="text-align: center;">SP – 15</td></tr> <tr><td style="text-align: center;">0013</td><td style="text-align: center;">SJ – N2.2A</td><td style="text-align: center;">10000 r/min</td><td style="text-align: center;">SP – 22</td></tr> <tr><td style="text-align: center;">0014</td><td style="text-align: center;">SJ – N3.7A</td><td style="text-align: center;">10000 r/min</td><td style="text-align: center;">SP – 37</td></tr> <tr><td style="text-align: center;">0015</td><td style="text-align: center;">SJ – N5.5A</td><td style="text-align: center;">8000 r/min</td><td style="text-align: center;">SP – 55</td></tr> <tr><td style="text-align: center;">0016</td><td style="text-align: center;">SJ – N7.5A</td><td style="text-align: center;">8000 r/min</td><td style="text-align: center;">SP – 75</td></tr> <tr><td style="text-align: center;">0017</td><td></td><td></td><td></td></tr> <tr><td style="text-align: center;">0018</td><td></td><td></td><td></td></tr> <tr><td style="text-align: center;">0019</td><td></td><td></td><td></td></tr> <tr><td style="text-align: center;">001A</td><td></td><td></td><td></td></tr> <tr><td style="text-align: center;">001B</td><td style="text-align: center;">SJ – J2.2A</td><td style="text-align: center;">10000 r/min</td><td style="text-align: center;">SP – 22</td></tr> <tr><td style="text-align: center;">001C</td><td style="text-align: center;">SJ – J3.7A</td><td style="text-align: center;">10000 r/min</td><td style="text-align: center;">SP – 37</td></tr> <tr><td style="text-align: center;">001D</td><td style="text-align: center;">SJ – J5.5A</td><td style="text-align: center;">8000 r/min</td><td style="text-align: center;">SP – 55</td></tr> <tr><td style="text-align: center;">001E</td><td style="text-align: center;">SJ – J7.5A</td><td style="text-align: center;">8000 r/min</td><td style="text-align: center;">SP – 75</td></tr> <tr><td style="text-align: center;">001F</td><td></td><td></td><td></td></tr> </tbody> </table> <p><b>(Note)</b> The above motor selection is valid only when "SP034 (SFNC2)" bit4 is set to "0".</p> <p>(Continued on the next page.)</p>	Parameter setting	Motor type	Maximum speed	Corresponding amplifier	0000				0001	SJ – 2.2A	10000 r/min	SP – 22	0002	SJ – 3.7A	10000 r/min	SP – 37	0003	SJ – 5.5A	8000 r/min	SP – 55	0004	SJ – 7.5A	8000 r/min	SP – 75	0005	SJ – 11A	6000 r/min	SP – 110	0006	SJ – 15A	6000 r/min	SP – 150	0007	SJ – 18.5A	6000 r/min	SP – 185	0008	SJ – 22A	4500 r/min	SP – 220	0009	SJ – 26A	4500 r/min	SP – 260	000A	SJ – 30A	4500 r/min	SP – 300	000B				000C				000D				000E				000F				0010				0011	SJ – N0.75A	10000 r/min	SP – 075	0012	SJ – N1.5A	10000 r/min	SP – 15	0013	SJ – N2.2A	10000 r/min	SP – 22	0014	SJ – N3.7A	10000 r/min	SP – 37	0015	SJ – N5.5A	8000 r/min	SP – 55	0016	SJ – N7.5A	8000 r/min	SP – 75	0017				0018				0019				001A				001B	SJ – J2.2A	10000 r/min	SP – 22	001C	SJ – J3.7A	10000 r/min	SP – 37	001D	SJ – J5.5A	8000 r/min	SP – 55	001E	SJ – J7.5A	8000 r/min	SP – 75	001F					
Parameter setting	Motor type	Maximum speed	Corresponding amplifier																																																																																																																																					
0000																																																																																																																																								
0001	SJ – 2.2A	10000 r/min	SP – 22																																																																																																																																					
0002	SJ – 3.7A	10000 r/min	SP – 37																																																																																																																																					
0003	SJ – 5.5A	8000 r/min	SP – 55																																																																																																																																					
0004	SJ – 7.5A	8000 r/min	SP – 75																																																																																																																																					
0005	SJ – 11A	6000 r/min	SP – 110																																																																																																																																					
0006	SJ – 15A	6000 r/min	SP – 150																																																																																																																																					
0007	SJ – 18.5A	6000 r/min	SP – 185																																																																																																																																					
0008	SJ – 22A	4500 r/min	SP – 220																																																																																																																																					
0009	SJ – 26A	4500 r/min	SP – 260																																																																																																																																					
000A	SJ – 30A	4500 r/min	SP – 300																																																																																																																																					
000B																																																																																																																																								
000C																																																																																																																																								
000D																																																																																																																																								
000E																																																																																																																																								
000F																																																																																																																																								
0010																																																																																																																																								
0011	SJ – N0.75A	10000 r/min	SP – 075																																																																																																																																					
0012	SJ – N1.5A	10000 r/min	SP – 15																																																																																																																																					
0013	SJ – N2.2A	10000 r/min	SP – 22																																																																																																																																					
0014	SJ – N3.7A	10000 r/min	SP – 37																																																																																																																																					
0015	SJ – N5.5A	8000 r/min	SP – 55																																																																																																																																					
0016	SJ – N7.5A	8000 r/min	SP – 75																																																																																																																																					
0017																																																																																																																																								
0018																																																																																																																																								
0019																																																																																																																																								
001A																																																																																																																																								
001B	SJ – J2.2A	10000 r/min	SP – 22																																																																																																																																					
001C	SJ – J3.7A	10000 r/min	SP – 37																																																																																																																																					
001D	SJ – J5.5A	8000 r/min	SP – 55																																																																																																																																					
001E	SJ – J7.5A	8000 r/min	SP – 75																																																																																																																																					
001F																																																																																																																																								

**4.8 Spindle Parameters**  
**4.8.2 Spindle Parameters**

#	Item	Details	Setting range (unit)	Standard setting																																																																																																																																																											
		<p><b>For SPJ2</b> (Continued from the previous page.)</p> <p>This parameter is valid when SP034 (SFNC2) bit0 is set to "0". Set the appropriate motor number by selecting it from the standard motors listed below.</p> <table border="1" style="width: 100%; border-collapse: collapse; margin-bottom: 10px;"> <thead> <tr> <th>Parameter setting</th> <th>Motor type</th> <th>Maximum speed</th> <th>Corre-sponding amplifier</th> </tr> </thead> <tbody> <tr><td>1000</td><td></td><td></td><td></td></tr> <tr><td>1001</td><td>SJ – P0.2A</td><td>10000 r/min</td><td>SPJ2 – 02</td></tr> <tr><td>1002</td><td>SJ – P0.4A</td><td>10000 r/min</td><td>SPJ2 – 04</td></tr> <tr><td>1003</td><td>SJ – P0.75A</td><td>10000 r/min</td><td>SPJ2 – 075</td></tr> <tr><td>1004</td><td>SJ – P1.5A</td><td>10000 r/min</td><td>SPJ2 – 15</td></tr> <tr><td>1005</td><td>SJ – P2.2A</td><td>8000 r/min</td><td>SPJ2 – 22</td></tr> <tr><td>1006</td><td>SJ – P3.7A</td><td>8000 r/min</td><td>SPJ2 – 37</td></tr> <tr><td>1007</td><td>SJ – PF5.5-01</td><td>8000 r/min</td><td>SPJ2 – 55</td></tr> <tr><td>1008</td><td>SJ – PF7.5-01</td><td>8000 r/min</td><td>SPJ2 – 75</td></tr> <tr><td>1009</td><td>SJ – PF11-01</td><td>6000 r/min</td><td>SPJ2 – 110/110C</td></tr> </tbody> </table> <p><b>(Note)</b> The above motor selection is valid only when "SP034 (SFNC2)" bit 4 is set to 0.</p>	Parameter setting	Motor type	Maximum speed	Corre-sponding amplifier	1000				1001	SJ – P0.2A	10000 r/min	SPJ2 – 02	1002	SJ – P0.4A	10000 r/min	SPJ2 – 04	1003	SJ – P0.75A	10000 r/min	SPJ2 – 075	1004	SJ – P1.5A	10000 r/min	SPJ2 – 15	1005	SJ – P2.2A	8000 r/min	SPJ2 – 22	1006	SJ – P3.7A	8000 r/min	SPJ2 – 37	1007	SJ – PF5.5-01	8000 r/min	SPJ2 – 55	1008	SJ – PF7.5-01	8000 r/min	SPJ2 – 75	1009	SJ – PF11-01	6000 r/min	SPJ2 – 110/110C	0000 to FFFF HEX setting	0000																																																																																																															
Parameter setting	Motor type	Maximum speed	Corre-sponding amplifier																																																																																																																																																												
1000																																																																																																																																																															
1001	SJ – P0.2A	10000 r/min	SPJ2 – 02																																																																																																																																																												
1002	SJ – P0.4A	10000 r/min	SPJ2 – 04																																																																																																																																																												
1003	SJ – P0.75A	10000 r/min	SPJ2 – 075																																																																																																																																																												
1004	SJ – P1.5A	10000 r/min	SPJ2 – 15																																																																																																																																																												
1005	SJ – P2.2A	8000 r/min	SPJ2 – 22																																																																																																																																																												
1006	SJ – P3.7A	8000 r/min	SPJ2 – 37																																																																																																																																																												
1007	SJ – PF5.5-01	8000 r/min	SPJ2 – 55																																																																																																																																																												
1008	SJ – PF7.5-01	8000 r/min	SPJ2 – 75																																																																																																																																																												
1009	SJ – PF11-01	6000 r/min	SPJ2 – 110/110C																																																																																																																																																												
3241	SP041 PTPY*	<p>Power supply type</p> <p>When this unit is a signal connection axis with power supply unit, set this parameter. Set "0" for this parameter for the unit which is not a signal connection axis.</p> <p><b>For SP/SPH</b></p> <table border="1" style="width: 100%; border-collapse: collapse; margin-bottom: 10px;"> <thead> <tr> <th>bit</th> <th>Name</th> <th>Meaning when set to 0</th> <th>Meaning when set to 1</th> </tr> </thead> <tbody> <tr> <td>0</td> <td rowspan="8">ptyp</td> <td colspan="2">Set the power supply type. (Select the type from the following table and set.)</td> </tr> <tr> <td>1</td> <td colspan="2"></td> </tr> <tr> <td>2</td> <td colspan="2"></td> </tr> <tr> <td>3</td> <td colspan="2"></td> </tr> <tr> <td>4</td> <td colspan="2"></td> </tr> <tr> <td>5</td> <td colspan="2"></td> </tr> <tr> <td>6</td> <td colspan="2"></td> </tr> <tr> <td>7</td> <td colspan="2"></td> </tr> <tr> <td colspan="2"></td> <td colspan="2"> <table border="1" style="width: 100%; border-collapse: collapse; margin-bottom: 10px;"> <thead> <tr> <th>ptyp</th> <th>Power supply type</th> <th>ptyp</th> <th>Power supply type</th> </tr> </thead> <tbody> <tr><td>00</td><td>Not connected</td><td>81</td><td>CR-10</td></tr> <tr><td>04</td><td>CV-37</td><td>82</td><td>CR-15</td></tr> <tr><td>06</td><td>CV-55</td><td>83</td><td>CR-22</td></tr> <tr><td>08</td><td>CV-75</td><td>84</td><td>CR-37</td></tr> <tr><td>11</td><td>CV-110</td><td>86</td><td>CR-55</td></tr> <tr><td>15</td><td>CV-150</td><td>88</td><td>CR-75</td></tr> <tr><td>19</td><td>CV-185</td><td>89</td><td>CR-90</td></tr> <tr><td>22</td><td>CV-220</td><td></td><td></td></tr> <tr><td>26</td><td>CV-260</td><td></td><td></td></tr> <tr><td>30</td><td>CV-300</td><td></td><td></td></tr> <tr><td>37</td><td>CV-370</td><td></td><td></td></tr> </tbody> </table> <p><b>(Note 1)</b> When using an external emergency stop in the MDS-B-CV, set a value of the above setting values with "40" added. <b>(Example)</b> When using an external emergency stop in CV-260, setting value = 0026 + 0040 = 0066</p> </td> </tr> <tr> <td>8</td> <td rowspan="4">rtyp</td> <td colspan="2">Set "0" if the power supply unit is a current regeneration type.</td> </tr> <tr> <td>9</td> <td colspan="2">If the power supply unit is a resistance regeneration type, set the type of resistor being used.</td> </tr> <tr> <td>A</td> <td colspan="2">(Select the type from the following table and set.)</td> </tr> <tr> <td>B</td> <td colspan="2"></td> </tr> <tr> <td colspan="2"></td> <td colspan="2"> <table border="1" style="width: 100%; border-collapse: collapse; margin-bottom: 10px;"> <thead> <tr> <th>rtyp</th> <th>External regenerative resistor type</th> <th>Resist-ance value (Ω)</th> <th>Watts (W)</th> </tr> </thead> <tbody> <tr><td>00</td><td>Not connected power supply</td><td>-</td><td>-</td></tr> <tr><td>01</td><td>GZG200W/260HMJ</td><td>26</td><td>80</td></tr> <tr><td>02</td><td>GZG300W/130HMJ*2</td><td>26</td><td>150</td></tr> <tr><td>03</td><td>MR-RB30</td><td>13</td><td>300</td></tr> <tr><td>04</td><td>MR-RB50</td><td>13</td><td>500</td></tr> <tr><td>05</td><td>GZG200W/200HMJ*3</td><td>6.7</td><td>350</td></tr> <tr><td>06</td><td>GZG300W/200HMJ*3</td><td>6.7</td><td>500</td></tr> <tr><td>07</td><td>R-UNIT-1</td><td>30</td><td>700</td></tr> <tr><td>08</td><td>R-UNIT-2</td><td>15</td><td>700</td></tr> <tr><td>09</td><td>R-UNIT-3</td><td>15</td><td>2.1K</td></tr> </tbody> </table> </td> </tr> <tr> <td>C</td> <td rowspan="4">amp</td> <td colspan="2">Set the driver model number.</td> </tr> <tr> <td>D</td> <td colspan="2">0: MDS-A-V1/V2/SP, MDS-B-V1/V2/V3/SP</td> </tr> <tr> <td>E</td> <td colspan="2">1: MDS-A-SVJ</td> </tr> <tr> <td>F</td> <td colspan="2">2: MDS-A-SPJ</td> </tr> </tbody> </table> <p>(Continued on the next page.)</p>	bit	Name	Meaning when set to 0	Meaning when set to 1	0	ptyp	Set the power supply type. (Select the type from the following table and set.)		1			2			3			4			5			6			7					<table border="1" style="width: 100%; border-collapse: collapse; margin-bottom: 10px;"> <thead> <tr> <th>ptyp</th> <th>Power supply type</th> <th>ptyp</th> <th>Power supply type</th> </tr> </thead> <tbody> <tr><td>00</td><td>Not connected</td><td>81</td><td>CR-10</td></tr> <tr><td>04</td><td>CV-37</td><td>82</td><td>CR-15</td></tr> <tr><td>06</td><td>CV-55</td><td>83</td><td>CR-22</td></tr> <tr><td>08</td><td>CV-75</td><td>84</td><td>CR-37</td></tr> <tr><td>11</td><td>CV-110</td><td>86</td><td>CR-55</td></tr> <tr><td>15</td><td>CV-150</td><td>88</td><td>CR-75</td></tr> <tr><td>19</td><td>CV-185</td><td>89</td><td>CR-90</td></tr> <tr><td>22</td><td>CV-220</td><td></td><td></td></tr> <tr><td>26</td><td>CV-260</td><td></td><td></td></tr> <tr><td>30</td><td>CV-300</td><td></td><td></td></tr> <tr><td>37</td><td>CV-370</td><td></td><td></td></tr> </tbody> </table> <p><b>(Note 1)</b> When using an external emergency stop in the MDS-B-CV, set a value of the above setting values with "40" added. <b>(Example)</b> When using an external emergency stop in CV-260, setting value = 0026 + 0040 = 0066</p>		ptyp	Power supply type	ptyp	Power supply type	00	Not connected	81	CR-10	04	CV-37	82	CR-15	06	CV-55	83	CR-22	08	CV-75	84	CR-37	11	CV-110	86	CR-55	15	CV-150	88	CR-75	19	CV-185	89	CR-90	22	CV-220			26	CV-260			30	CV-300			37	CV-370			8	rtyp	Set "0" if the power supply unit is a current regeneration type.		9	If the power supply unit is a resistance regeneration type, set the type of resistor being used.		A	(Select the type from the following table and set.)		B					<table border="1" style="width: 100%; border-collapse: collapse; margin-bottom: 10px;"> <thead> <tr> <th>rtyp</th> <th>External regenerative resistor type</th> <th>Resist-ance value (Ω)</th> <th>Watts (W)</th> </tr> </thead> <tbody> <tr><td>00</td><td>Not connected power supply</td><td>-</td><td>-</td></tr> <tr><td>01</td><td>GZG200W/260HMJ</td><td>26</td><td>80</td></tr> <tr><td>02</td><td>GZG300W/130HMJ*2</td><td>26</td><td>150</td></tr> <tr><td>03</td><td>MR-RB30</td><td>13</td><td>300</td></tr> <tr><td>04</td><td>MR-RB50</td><td>13</td><td>500</td></tr> <tr><td>05</td><td>GZG200W/200HMJ*3</td><td>6.7</td><td>350</td></tr> <tr><td>06</td><td>GZG300W/200HMJ*3</td><td>6.7</td><td>500</td></tr> <tr><td>07</td><td>R-UNIT-1</td><td>30</td><td>700</td></tr> <tr><td>08</td><td>R-UNIT-2</td><td>15</td><td>700</td></tr> <tr><td>09</td><td>R-UNIT-3</td><td>15</td><td>2.1K</td></tr> </tbody> </table>		rtyp	External regenerative resistor type	Resist-ance value (Ω)	Watts (W)	00	Not connected power supply	-	-	01	GZG200W/260HMJ	26	80	02	GZG300W/130HMJ*2	26	150	03	MR-RB30	13	300	04	MR-RB50	13	500	05	GZG200W/200HMJ*3	6.7	350	06	GZG300W/200HMJ*3	6.7	500	07	R-UNIT-1	30	700	08	R-UNIT-2	15	700	09	R-UNIT-3	15	2.1K	C	amp	Set the driver model number.		D	0: MDS-A-V1/V2/SP, MDS-B-V1/V2/V3/SP		E	1: MDS-A-SVJ		F	2: MDS-A-SPJ		0000 to FFFF HEX setting	0000
bit	Name	Meaning when set to 0	Meaning when set to 1																																																																																																																																																												
0	ptyp	Set the power supply type. (Select the type from the following table and set.)																																																																																																																																																													
1																																																																																																																																																															
2																																																																																																																																																															
3																																																																																																																																																															
4																																																																																																																																																															
5																																																																																																																																																															
6																																																																																																																																																															
7																																																																																																																																																															
		<table border="1" style="width: 100%; border-collapse: collapse; margin-bottom: 10px;"> <thead> <tr> <th>ptyp</th> <th>Power supply type</th> <th>ptyp</th> <th>Power supply type</th> </tr> </thead> <tbody> <tr><td>00</td><td>Not connected</td><td>81</td><td>CR-10</td></tr> <tr><td>04</td><td>CV-37</td><td>82</td><td>CR-15</td></tr> <tr><td>06</td><td>CV-55</td><td>83</td><td>CR-22</td></tr> <tr><td>08</td><td>CV-75</td><td>84</td><td>CR-37</td></tr> <tr><td>11</td><td>CV-110</td><td>86</td><td>CR-55</td></tr> <tr><td>15</td><td>CV-150</td><td>88</td><td>CR-75</td></tr> <tr><td>19</td><td>CV-185</td><td>89</td><td>CR-90</td></tr> <tr><td>22</td><td>CV-220</td><td></td><td></td></tr> <tr><td>26</td><td>CV-260</td><td></td><td></td></tr> <tr><td>30</td><td>CV-300</td><td></td><td></td></tr> <tr><td>37</td><td>CV-370</td><td></td><td></td></tr> </tbody> </table> <p><b>(Note 1)</b> When using an external emergency stop in the MDS-B-CV, set a value of the above setting values with "40" added. <b>(Example)</b> When using an external emergency stop in CV-260, setting value = 0026 + 0040 = 0066</p>		ptyp	Power supply type	ptyp	Power supply type	00	Not connected	81	CR-10	04	CV-37	82	CR-15	06	CV-55	83	CR-22	08	CV-75	84	CR-37	11	CV-110	86	CR-55	15	CV-150	88	CR-75	19	CV-185	89	CR-90	22	CV-220			26	CV-260			30	CV-300			37	CV-370																																																																																																														
ptyp	Power supply type	ptyp	Power supply type																																																																																																																																																												
00	Not connected	81	CR-10																																																																																																																																																												
04	CV-37	82	CR-15																																																																																																																																																												
06	CV-55	83	CR-22																																																																																																																																																												
08	CV-75	84	CR-37																																																																																																																																																												
11	CV-110	86	CR-55																																																																																																																																																												
15	CV-150	88	CR-75																																																																																																																																																												
19	CV-185	89	CR-90																																																																																																																																																												
22	CV-220																																																																																																																																																														
26	CV-260																																																																																																																																																														
30	CV-300																																																																																																																																																														
37	CV-370																																																																																																																																																														
8	rtyp	Set "0" if the power supply unit is a current regeneration type.																																																																																																																																																													
9		If the power supply unit is a resistance regeneration type, set the type of resistor being used.																																																																																																																																																													
A		(Select the type from the following table and set.)																																																																																																																																																													
B																																																																																																																																																															
		<table border="1" style="width: 100%; border-collapse: collapse; margin-bottom: 10px;"> <thead> <tr> <th>rtyp</th> <th>External regenerative resistor type</th> <th>Resist-ance value (Ω)</th> <th>Watts (W)</th> </tr> </thead> <tbody> <tr><td>00</td><td>Not connected power supply</td><td>-</td><td>-</td></tr> <tr><td>01</td><td>GZG200W/260HMJ</td><td>26</td><td>80</td></tr> <tr><td>02</td><td>GZG300W/130HMJ*2</td><td>26</td><td>150</td></tr> <tr><td>03</td><td>MR-RB30</td><td>13</td><td>300</td></tr> <tr><td>04</td><td>MR-RB50</td><td>13</td><td>500</td></tr> <tr><td>05</td><td>GZG200W/200HMJ*3</td><td>6.7</td><td>350</td></tr> <tr><td>06</td><td>GZG300W/200HMJ*3</td><td>6.7</td><td>500</td></tr> <tr><td>07</td><td>R-UNIT-1</td><td>30</td><td>700</td></tr> <tr><td>08</td><td>R-UNIT-2</td><td>15</td><td>700</td></tr> <tr><td>09</td><td>R-UNIT-3</td><td>15</td><td>2.1K</td></tr> </tbody> </table>		rtyp	External regenerative resistor type	Resist-ance value (Ω)	Watts (W)	00	Not connected power supply	-	-	01	GZG200W/260HMJ	26	80	02	GZG300W/130HMJ*2	26	150	03	MR-RB30	13	300	04	MR-RB50	13	500	05	GZG200W/200HMJ*3	6.7	350	06	GZG300W/200HMJ*3	6.7	500	07	R-UNIT-1	30	700	08	R-UNIT-2	15	700	09	R-UNIT-3	15	2.1K																																																																																																																
rtyp	External regenerative resistor type	Resist-ance value (Ω)	Watts (W)																																																																																																																																																												
00	Not connected power supply	-	-																																																																																																																																																												
01	GZG200W/260HMJ	26	80																																																																																																																																																												
02	GZG300W/130HMJ*2	26	150																																																																																																																																																												
03	MR-RB30	13	300																																																																																																																																																												
04	MR-RB50	13	500																																																																																																																																																												
05	GZG200W/200HMJ*3	6.7	350																																																																																																																																																												
06	GZG300W/200HMJ*3	6.7	500																																																																																																																																																												
07	R-UNIT-1	30	700																																																																																																																																																												
08	R-UNIT-2	15	700																																																																																																																																																												
09	R-UNIT-3	15	2.1K																																																																																																																																																												
C	amp	Set the driver model number.																																																																																																																																																													
D		0: MDS-A-V1/V2/SP, MDS-B-V1/V2/V3/SP																																																																																																																																																													
E		1: MDS-A-SVJ																																																																																																																																																													
F		2: MDS-A-SPJ																																																																																																																																																													

## 4.8 Spindle Parameters

### 4.8.2 Spindle Parameters

#	Item	Details	Setting range (unit)	Standard setting																																																												
		<p><b>For SPJ2</b> (Continued from the previous page.)</p> <p>Select a value from the following table according to the regenerative resistor being used.</p> <table border="1" style="width: 100%; border-collapse: collapse;"> <thead> <tr> <th style="text-align: center;">Setting value</th> <th style="text-align: center;">Regenerative resistor type</th> <th style="text-align: center;">Resist-ance value (<math>\Omega</math>)</th> <th style="text-align: center;">Capacity (W)</th> </tr> </thead> <tbody> <tr><td>0000</td><td style="text-align: center;">—</td><td style="text-align: center;">—</td><td style="text-align: center;">—</td></tr> <tr><td>2000</td><td style="text-align: center;">Not connected</td><td style="text-align: center;">—</td><td style="text-align: center;">—</td></tr> <tr><td>2100</td><td style="text-align: center;">FCUA-RB04</td><td style="text-align: center;">200</td><td style="text-align: center;">60</td></tr> <tr><td>2200</td><td style="text-align: center;">FCUA-RB075</td><td style="text-align: center;">100</td><td style="text-align: center;">80</td></tr> <tr><td>2300</td><td style="text-align: center;">FCUA-RB15</td><td style="text-align: center;">60</td><td style="text-align: center;">120</td></tr> <tr><td>2400</td><td style="text-align: center;">FCUA-RB22</td><td style="text-align: center;">40</td><td style="text-align: center;">155</td></tr> <tr><td>2500</td><td style="text-align: center;">FCUA-RB37</td><td style="text-align: center;">25</td><td style="text-align: center;">185</td></tr> <tr><td>2600</td><td style="text-align: center;">FCUA-RB55</td><td style="text-align: center;">20</td><td style="text-align: center;">340</td></tr> <tr><td>2700</td><td style="text-align: center;">FCUA-RB75/2</td><td style="text-align: center;">30/15</td><td style="text-align: center;">340/680</td></tr> <tr><td>2800</td><td style="text-align: center;">R-UNIT-1</td><td style="text-align: center;">30</td><td style="text-align: center;">700</td></tr> <tr><td>2900</td><td style="text-align: center;">R-UNIT-2</td><td style="text-align: center;">15</td><td style="text-align: center;">700</td></tr> <tr><td>2A00</td><td style="text-align: center;">R-UNIT-3</td><td style="text-align: center;">15</td><td style="text-align: center;">2100</td></tr> <tr><td>2B00</td><td style="text-align: center;">R-UNIT-4</td><td style="text-align: center;">10</td><td style="text-align: center;">2100</td></tr> <tr><td>2C00</td><td style="text-align: center;">R-UNIT-5</td><td style="text-align: center;">10</td><td style="text-align: center;">3100</td></tr> </tbody> </table> <p><b>(Note 1)</b> This setting is also used when two FCUA-RB75/2s are used in parallel as well as one.</p>	Setting value	Regenerative resistor type	Resist-ance value ( $\Omega$ )	Capacity (W)	0000	—	—	—	2000	Not connected	—	—	2100	FCUA-RB04	200	60	2200	FCUA-RB075	100	80	2300	FCUA-RB15	60	120	2400	FCUA-RB22	40	155	2500	FCUA-RB37	25	185	2600	FCUA-RB55	20	340	2700	FCUA-RB75/2	30/15	340/680	2800	R-UNIT-1	30	700	2900	R-UNIT-2	15	700	2A00	R-UNIT-3	15	2100	2B00	R-UNIT-4	10	2100	2C00	R-UNIT-5	10	3100		
Setting value	Regenerative resistor type	Resist-ance value ( $\Omega$ )	Capacity (W)																																																													
0000	—	—	—																																																													
2000	Not connected	—	—																																																													
2100	FCUA-RB04	200	60																																																													
2200	FCUA-RB075	100	80																																																													
2300	FCUA-RB15	60	120																																																													
2400	FCUA-RB22	40	155																																																													
2500	FCUA-RB37	25	185																																																													
2600	FCUA-RB55	20	340																																																													
2700	FCUA-RB75/2	30/15	340/680																																																													
2800	R-UNIT-1	30	700																																																													
2900	R-UNIT-2	15	700																																																													
2A00	R-UNIT-3	15	2100																																																													
2B00	R-UNIT-4	10	2100																																																													
2C00	R-UNIT-5	10	3100																																																													
3242	SP042	CRNG* C-axis detector range	This parameter is used to set the C-axis detector range. Set "0" for this parameter.	0 to 7 0																																																												
3243	SP043	TRNG* Synchronous tapping, spindle synchronous detector range	This parameter is used to set the synchronous tapping or spindle synchronous detector range. Set "0" for this parameter.	0 to 7 0																																																												
3244	SP044	TRANS* NC communication frequency	Set a frequency of data communication with NC.	0 to 32767 Standard: 0 Special: 1028																																																												
3245	SP045	CSNT Dual cushion timer	Set the cycle to add the increment values in the dual cushion process. Increasing the setting value elongates the dual cushion process, and the changes in the speed during acceleration/deceleration becomes gradual.	0 to 1000 (ms) 0																																																												
3246	SP046	CSN2* Speed command dual cushion	For an acceleration/deceleration time constant defined in SP019 (CSN1), this parameter is used to provide smooth movement only at the start of acceleration/deceleration. As the value of this parameter is smaller, it moves smoother but the acceleration/deceleration time becomes longer. To make this parameter invalid, set "0".	0 to 1000 0																																																												
3247	SP047	SDTR* Speed detection reset value	Set the reset hysteresis width for a speed detection set value defined in SP020 (SDTS).	0 to 1000 (r/min) 30																																																												
3248	SP048	SUT* Speed reach range	Set the speed deviation rate with respect to the commanded speed for output of the speed reach signal.	0 to 100 (%) 15																																																												
3249	SP049	TLM2 Torque limit 2	Set the torque limit rate for the torque limit signal 010.	1 to 120 (%) 20																																																												

## 4.8 Spindle Parameters

### 4.8.2 Spindle Parameters

#	Item			Details	Setting range (unit)	Standard setting
3250	SP050	TLM3	Torque limit 3	Set the torque limit rate for the torque limit signal 011.	0 to 120 (%)	30
3251	SP051	TLM4	Torque limit 4	Set the torque limit rate for the torque limit signal 100.	0 to 120 (%)	40
3252	SP052	TLM5	Torque limit 5	Set the torque limit rate for the torque limit signal 101.	0 to 120 (%)	50
3253	SP053	TLM6	Torque limit 6	Set the torque limit rate for the torque limit signal 110.	0 to 120 (%)	60
3254	SP054	TLM7	Torque limit 7	Set the torque limit rate for the torque limit signal 111.	0 to 120 (%)	70
3255	SP055	SETM*	Excessive speed deviation timer	Set the timer value until the excessive so speed deviation alarm is output. The value of this parameter should be longer than the acceleration/deceleration time.	0 to 60 (s)	12
3256	SP056	PYVR	Variable excitation (min value)	Set the minimum value of the variable excitation rate. Select a smaller value when gear noise is too high. However, a larger value is effective for impact response.	0 to 100 (%)	50
3257	SP057	STOD*	Fixed control constant	Set by Mitsubishi. Set "0" unless designated in particular.	0	0
3258	SP058	SDT2*	Fixed control constant	Set by Mitsubishi. Set "0" unless designated in particular.	0	0
3259	SP059	MKT*	Winding changeover base shut-off timer	Set the base shut-off time for contactor switching at winding changeover. Note that the contactor may damaged with burning if the value of this parameter is too small.	50 to 10000 (ms)	150
3260	SP060	MKT2*	Current limit timer after winding changeover	Set the current limit time to be taken after completion of contactor switching at winding changeover.	0 to 10000 (ms)	500
3261	SP061	MKIL*	Current limit value after winding changeover	Set the current limit value for operation during a period defined in SP060 (MKT2) after completion of contactor switching at winding changeover.	0 to 120 (%)	75
3262	SP062			Not used. Set to "0".	0	0
3263	SP063	OLT*	Overload alarm detection time	Set the time constant for detection of the motor overload alarm.	0 to 1000 (s)	60
3264	SP064	OLL*	Overload alarm detection level	Set the detection level of the motor overload alarm.	0 to 120 (%)	110
3265	SP065	VCGN1*	Target value of variable speed loop proportional gain	Set the magnification of speed loop proportional gain with respect to SP022 (VGNP1) at the maximum motor speed defined in SP017 (TSP).	0 to 100 (%)	100

## 4.8 Spindle Parameters

### 4.8.2 Spindle Parameters

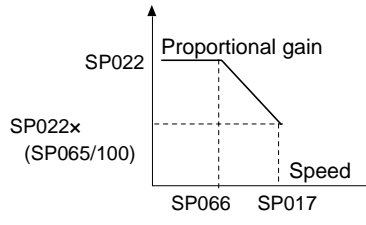
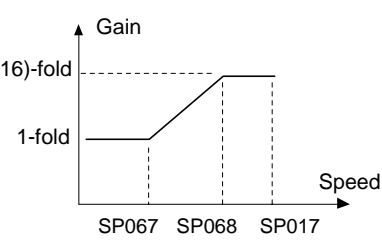
#	Item		Details	Setting range (unit)	Standard setting																	
3266	SP066	VCSN1*	Change starting speed of variable speed loop proportional gain	Set the speed for starting change of speed loop proportional gain. 	0 to 32767 (r/min)	0																
3267	SP067	VIGWA*	Change starting speed of variable current loop gain	Set the speed for starting change of current loop gain.	0 to 32767 (r/min)	0																
3268	SP068	VIGWB*	Change ending speed of variable current loop gain	Set the speed for ending change of current loop gain.	0 to 32767 (r/min)	0																
3269	SP069	VIGN*	Target value of variable current loop gain	Set the magnification of current loop gain (torque component and excitation component) for a change ending speed defined in SP068 (VIGWB). When this parameter is set to "0", the magnification is 1. 	0 to 32767 (1/16-fold)	0																
				<table border="1" style="width: 100%; border-collapse: collapse; text-align: center;"> <thead> <tr> <th>SP017 (TSP) Maximum motor speed</th> <th>SP067 (VIGWA)</th> <th>SP068 (VIGWB)</th> <th>SP069 (VIGN)</th> </tr> </thead> <tbody> <tr> <td>0 to 6000</td> <td>0</td> <td>0</td> <td>0</td> </tr> <tr> <td>6001 to 8000</td> <td>5000</td> <td>8000</td> <td>45</td> </tr> <tr> <td>8001 or more</td> <td>5000</td> <td>10000</td> <td>64</td> </tr> </tbody> </table>	SP017 (TSP) Maximum motor speed	SP067 (VIGWA)	SP068 (VIGWB)	SP069 (VIGN)	0 to 6000	0	0	0	6001 to 8000	5000	8000	45	8001 or more	5000	10000	64		
SP017 (TSP) Maximum motor speed	SP067 (VIGWA)	SP068 (VIGWB)	SP069 (VIGN)																			
0 to 6000	0	0	0																			
6001 to 8000	5000	8000	45																			
8001 or more	5000	10000	64																			
3270	SP070	FHz	Machine resonance suppression filter frequency	When machine vibration occurs in speed and position control, set the frequency of the required vibration suppression. Note that a value of 100Hz or more is set. Set to "0" when not used.	100 to 3000 (Hz)	0																
3271	SP071	VR2WA*	Fixed control constant	Set by Mitsubishi. Set "0" unless designated in particular.	0	0																
3272	SP072	VR2WB*																				
3273	SP073	VR2GN*																				
3274	SP074	IGDEC*																				
3275	SP075	R2KWS																				



## 4.8 Spindle Parameters

### 4.8.2 Spindle Parameters

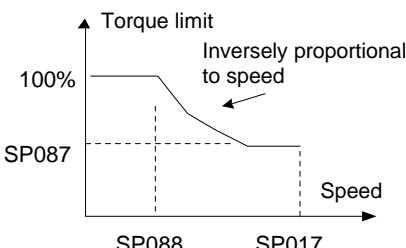
#	Item		Details	Setting range (unit)	Standard setting	
3276	SP076	FONS	Machine resonance suppression filter operation speed	When the vibration increases in motor stop (ex. in orientation stop) when the machine vibration suppression filter is operated by SP070, operate the machine vibration suppression filter at a speed of this parameter or more. When set to "0", this is validated for all speeds.	0 to 32767 (r/min)	0
3277	SP077	TDSL	Fixed control constant	Set by Mitsubishi. Set "0" unless designated in particular.		14
3278	SP078	FPWM*	Fixed control constant	Set by Mitsubishi. Set "0" unless designated in particular.	0	0
3279	SP079	ILMT*				
3280	SP080					
3281	SP081	LMCA				
3282	SP082	LMCB				
3283 to 3286	SP083 to SP086		Not used. Set to "0".	0	0	
3287	P087	DIQM*	Target value of variable torque limit magnification at deceleration	Set the minimum value of variable torque limit at deceleration.	0 to 150 (%)	75
3288	SP088	DIQN*	Speed for starting change of variable torque limit magnification at deceleration	Set the speed for starting change of torque limit value at deceleration. 	0 to 32767 (r/min)	3000
3289	SP089		Not used. Set to "0".	0	0	
3290	SP090		Not used. Set to "0".	0	0	
3291	SP091	OFSN	Motor PLG forward rotation offset compensation	Set the PLG offset value for the forward rotation. Normally set to "0".	-2048 to 2047 (-1mv)	0
3292	SP092	OFSI	Motor PLG reverse rotation offset compensation	Set the PLG offset value for the reverse rotation. Normally set to "0".	-2048 to 2047 (-1mv)	0
3293	SP093	ORE*	Fixed control constant	Set by Mitsubishi. Set "0" unless designated in particular.	0	0
3294	SP094	LMAV*	Load meter output filter	Set the filter time constant of load meter output. When "0" is set, a filter time constant is set to 100ms.	0 to 32767 (2ms)	0

**4.8 Spindle Parameters**  
**4.8.2 Spindle Parameters**

#	Item	Details	Setting range (unit)	Standard setting																																																																																																																
3295	SP095 VFAV*	Fixed control constant	Set by Mitsubishi. Set "0" unless designated in particular.	0																																																																																																																
3296	SP096 EGAR*	Encoder gear ratio	Set the gear ratio between the spindle end and the encoder end (except for the motor-built-in encoder) as indicated below.  <table border="1" style="margin-left: auto; margin-right: auto;"> <thead> <tr> <th>Setting value</th> <th>Gear ratio (deceleration)</th> <th>Setting value</th> <th>Gear ratio (Acceleration)</th> </tr> </thead> <tbody> <tr> <td>0</td> <td>1 : 1</td> <td>-1</td> <td>1 : 2</td> </tr> <tr> <td>1</td> <td>1 : 1/2</td> <td>-2</td> <td>1 : 4</td> </tr> <tr> <td>2</td> <td>1 : 1/4</td> <td>-3</td> <td>1 : 3</td> </tr> <tr> <td>3</td> <td>1 : 1/8</td> <td></td> <td></td> </tr> <tr> <td>4</td> <td>1 : 1/16</td> <td></td> <td></td> </tr> </tbody> </table>	Setting value	Gear ratio (deceleration)	Setting value	Gear ratio (Acceleration)	0	1 : 1	-1	1 : 2	1	1 : 1/2	-2	1 : 4	2	1 : 1/4	-3	1 : 3	3	1 : 1/8			4	1 : 1/16			-3 to 4																																																																																								
Setting value	Gear ratio (deceleration)	Setting value	Gear ratio (Acceleration)																																																																																																																	
0	1 : 1	-1	1 : 2																																																																																																																	
1	1 : 1/2	-2	1 : 4																																																																																																																	
2	1 : 1/4	-3	1 : 3																																																																																																																	
3	1 : 1/8																																																																																																																			
4	1 : 1/16																																																																																																																			
3297	SP097 SPECO*	Orientation specification	<p><b>For SPJ2</b></p> <p>Set the orientation specifications in bit units.</p> <table style="margin-left: auto; margin-right: auto;"> <tr> <td style="border: 1px solid black; width: 20px; text-align: center;">F</td> <td style="border: 1px solid black; width: 20px; text-align: center;">E</td> <td style="border: 1px solid black; width: 20px; text-align: center;">D</td> <td style="border: 1px solid black; width: 20px; text-align: center;">C</td> <td style="border: 1px solid black; width: 20px; text-align: center;">B</td> <td style="border: 1px solid black; width: 20px; text-align: center;">A</td> <td style="border: 1px solid black; width: 20px; text-align: center;">9</td> <td style="border: 1px solid black; width: 20px; text-align: center;">8</td> </tr> <tr> <td style="border: 1px solid black; width: 20px; text-align: center;">tlet</td> <td colspan="7"></td> </tr> <tr> <td style="border: 1px solid black; width: 20px; text-align: center;">7</td> <td style="border: 1px solid black; width: 20px; text-align: center;">6</td> <td style="border: 1px solid black; width: 20px; text-align: center;">5</td> <td style="border: 1px solid black; width: 20px; text-align: center;">4</td> <td style="border: 1px solid black; width: 20px; text-align: center;">3</td> <td style="border: 1px solid black; width: 20px; text-align: center;">2</td> <td style="border: 1px solid black; width: 20px; text-align: center;">1</td> <td style="border: 1px solid black; width: 20px; text-align: center;">0</td> </tr> <tr> <td style="border: 1px solid black; width: 20px; text-align: center;">fdir</td> <td style="border: 1px solid black; width: 20px; text-align: center;">pyfx</td> <td style="border: 1px solid black; width: 20px; text-align: center;">dmin</td> <td style="border: 1px solid black; width: 20px; text-align: center;">odi2</td> <td style="border: 1px solid black; width: 20px; text-align: center;">odi1</td> <td colspan="3"></td> </tr> </table> <p><b>(Note)</b> Always set "0" for the empty bits.</p> <table border="1" style="margin-left: auto; margin-right: auto;"> <thead> <tr> <th>bit</th> <th>Name</th> <th>Meaning when set to 0</th> <th>Meaning when set to 1</th> </tr> </thead> <tbody> <tr> <td>0</td> <td>odi1</td> <td colspan="2">Orientation rotation direction</td> </tr> <tr> <td></td> <td>odi2</td> <td colspan="2">00: Previous (the direction in which the motor has so far rotated under speed control)</td> </tr> <tr> <td>1</td> <td></td> <td colspan="2">01: Forward rotation</td> </tr> <tr> <td></td> <td></td> <td colspan="2">10: Backward rotation</td> </tr> <tr> <td></td> <td></td> <td colspan="2">11: Prohibited (Same as setting value = 10)</td> </tr> <tr> <td>2</td> <td>dmin</td> <td>Dummy in-position invalid</td> <td>Dummy in-position valid</td> </tr> <tr> <td>3</td> <td>pyfx</td> <td>Excitation min. (50%) during orientation servo lock invalid</td> <td>Excitation min. (50%) during orientation servo lock valid</td> </tr> <tr> <td>4</td> <td></td> <td></td> <td></td> </tr> <tr> <td>5</td> <td>fdir</td> <td>Encoder detector polarity: +</td> <td>Encoder detector polarity: -</td> </tr> <tr> <td>6</td> <td></td> <td></td> <td></td> </tr> <tr> <td>7</td> <td></td> <td></td> <td></td> </tr> <tr> <td>8</td> <td>tlet</td> <td>Turret indexing invalid</td> <td>Turret indexing valid</td> </tr> <tr> <td>9</td> <td></td> <td></td> <td></td> </tr> <tr> <td>A</td> <td></td> <td></td> <td></td> </tr> <tr> <td>B</td> <td></td> <td></td> <td></td> </tr> <tr> <td>C</td> <td></td> <td></td> <td></td> </tr> <tr> <td>D</td> <td></td> <td></td> <td></td> </tr> <tr> <td>E</td> <td></td> <td></td> <td></td> </tr> <tr> <td>F</td> <td></td> <td></td> <td></td> </tr> </tbody> </table> <p>(Continued on the next page.)</p>	F	E	D	C	B	A	9	8	tlet								7	6	5	4	3	2	1	0	fdir	pyfx	dmin	odi2	odi1				bit	Name	Meaning when set to 0	Meaning when set to 1	0	odi1	Orientation rotation direction			odi2	00: Previous (the direction in which the motor has so far rotated under speed control)		1		01: Forward rotation				10: Backward rotation				11: Prohibited (Same as setting value = 10)		2	dmin	Dummy in-position invalid	Dummy in-position valid	3	pyfx	Excitation min. (50%) during orientation servo lock invalid	Excitation min. (50%) during orientation servo lock valid	4				5	fdir	Encoder detector polarity: +	Encoder detector polarity: -	6				7				8	tlet	Turret indexing invalid	Turret indexing valid	9				A				B				C				D				E				F				0000 to FFFF HEX setting
F	E	D	C	B	A	9	8																																																																																																													
tlet																																																																																																																				
7	6	5	4	3	2	1	0																																																																																																													
fdir	pyfx	dmin	odi2	odi1																																																																																																																
bit	Name	Meaning when set to 0	Meaning when set to 1																																																																																																																	
0	odi1	Orientation rotation direction																																																																																																																		
	odi2	00: Previous (the direction in which the motor has so far rotated under speed control)																																																																																																																		
1		01: Forward rotation																																																																																																																		
		10: Backward rotation																																																																																																																		
		11: Prohibited (Same as setting value = 10)																																																																																																																		
2	dmin	Dummy in-position invalid	Dummy in-position valid																																																																																																																	
3	pyfx	Excitation min. (50%) during orientation servo lock invalid	Excitation min. (50%) during orientation servo lock valid																																																																																																																	
4																																																																																																																				
5	fdir	Encoder detector polarity: +	Encoder detector polarity: -																																																																																																																	
6																																																																																																																				
7																																																																																																																				
8	tlet	Turret indexing invalid	Turret indexing valid																																																																																																																	
9																																																																																																																				
A																																																																																																																				
B																																																																																																																				
C																																																																																																																				
D																																																																																																																				
E																																																																																																																				
F																																																																																																																				

**4.8 Spindle Parameters**  
**4.8.2 Spindle Parameters**

#	Item	Details	Setting range (unit)	Standard setting																																																																																																		
		<p><b>For spindle-type servo</b></p> <p>(Continued from the previous page.)</p> <p>Set the orientation specifications in bit units.</p> <table style="margin-left: auto; margin-right: auto; border-collapse: collapse;"> <tr> <td style="padding: 2px 10px;">F</td><td style="padding: 2px 10px;">E</td><td style="padding: 2px 10px;">D</td><td style="padding: 2px 10px;">C</td><td style="padding: 2px 10px;">B</td><td style="padding: 2px 10px;">A</td><td style="padding: 2px 10px;">9</td><td style="padding: 2px 10px;">8</td> </tr> <tr> <td style="border: 1px solid black; width: 20px; height: 15px;"></td><td style="border: 1px solid black; width: 20px; height: 15px;"></td><td style="border: 1px solid black; width: 20px; height: 15px;"></td><td style="border: 1px solid black; width: 20px; height: 15px;"></td><td style="border: 1px solid black; width: 20px; height: 15px;"></td><td style="border: 1px solid black; width: 20px; height: 15px;"></td><td style="border: 1px solid black; width: 20px; height: 15px;"></td><td style="border: 1px solid black; width: 20px; height: 15px;"></td> </tr> </table> <table style="margin-left: auto; margin-right: auto; border-collapse: collapse;"> <tr> <td style="padding: 2px 10px;">7</td><td style="padding: 2px 10px;">6</td><td style="padding: 2px 10px;">5</td><td style="padding: 2px 10px;">4</td><td style="padding: 2px 10px;">3</td><td style="padding: 2px 10px;">2</td><td style="padding: 2px 10px;">1</td><td style="padding: 2px 10px;">0</td> </tr> <tr> <td style="border: 1px solid black; width: 20px; height: 15px;"></td><td style="border: 1px solid black; width: 20px; height: 15px;"></td><td style="border: 1px solid black; width: 20px; height: 15px;"></td><td style="border: 1px solid black; width: 20px; height: 15px;"></td><td style="border: 1px solid black; width: 20px; height: 15px;"></td><td style="border: 1px solid black; width: 20px; height: 15px;"></td><td style="border: 1px solid black; width: 20px; height: 15px; text-align: center;">odi2</td><td style="border: 1px solid black; width: 20px; height: 15px; text-align: center;">odi1</td> </tr> </table> <p><b>(Note)</b> Always set "0" for the empty bits.</p> <table border="1" style="margin-left: auto; margin-right: auto; border-collapse: collapse; width: 100%;"> <thead> <tr> <th style="width: 5%;">bit</th> <th style="width: 15%;">Name</th> <th style="width: 40%;">Meaning when set to 0</th> <th style="width: 40%;">Meaning when set to 1</th> </tr> </thead> <tbody> <tr> <td style="text-align: center;">0</td> <td style="text-align: center;">odi1 odi2</td> <td colspan="2" rowspan="2">Oriented rotary direction 00: Previous (the direction in which the motor has so far rotated under speed control) 01: Forward rotation 10: Backward rotation 11: Prohibited (Same as setting value = 10)</td> </tr> <tr> <td style="text-align: center;">1</td> <td></td> </tr> <tr><td style="text-align: center;">2</td><td></td><td></td><td></td></tr> <tr><td style="text-align: center;">3</td><td></td><td></td><td></td></tr> <tr><td style="text-align: center;">4</td><td></td><td></td><td></td></tr> <tr><td style="text-align: center;">5</td><td></td><td></td><td></td></tr> <tr><td style="text-align: center;">6</td><td></td><td></td><td></td></tr> <tr><td style="text-align: center;">7</td><td></td><td></td><td></td></tr> <tr><td style="text-align: center;">8</td><td></td><td></td><td></td></tr> <tr><td style="text-align: center;">9</td><td></td><td></td><td></td></tr> <tr><td style="text-align: center;">A</td><td></td><td></td><td></td></tr> <tr><td style="text-align: center;">B</td><td></td><td></td><td></td></tr> <tr><td style="text-align: center;">C</td><td></td><td></td><td></td></tr> <tr><td style="text-align: center;">D</td><td></td><td></td><td></td></tr> <tr><td style="text-align: center;">E</td><td></td><td></td><td></td></tr> <tr><td style="text-align: center;">F</td><td></td><td></td><td></td></tr> </tbody> </table> <p>(Continued on the next page.)</p>	F	E	D	C	B	A	9	8									7	6	5	4	3	2	1	0							odi2	odi1	bit	Name	Meaning when set to 0	Meaning when set to 1	0	odi1 odi2	Oriented rotary direction 00: Previous (the direction in which the motor has so far rotated under speed control) 01: Forward rotation 10: Backward rotation 11: Prohibited (Same as setting value = 10)		1		2				3				4				5				6				7				8				9				A				B				C				D				E				F				0000 to FFFF HEX setting	0000
F	E	D	C	B	A	9	8																																																																																															
7	6	5	4	3	2	1	0																																																																																															
						odi2	odi1																																																																																															
bit	Name	Meaning when set to 0	Meaning when set to 1																																																																																																			
0	odi1 odi2	Oriented rotary direction 00: Previous (the direction in which the motor has so far rotated under speed control) 01: Forward rotation 10: Backward rotation 11: Prohibited (Same as setting value = 10)																																																																																																				
1																																																																																																						
2																																																																																																						
3																																																																																																						
4																																																																																																						
5																																																																																																						
6																																																																																																						
7																																																																																																						
8																																																																																																						
9																																																																																																						
A																																																																																																						
B																																																																																																						
C																																																																																																						
D																																																																																																						
E																																																																																																						
F																																																																																																						

## 4.8 Spindle Parameters

### 4.8.2 Spindle Parameters

#	Item	Details	Setting range (unit)	Standard setting																																																																																																																						
		<p><b>For others</b> (Continued from the previous page.)</p> <p>Set the orientation specifications in bit units.</p> <table style="width: 100%; text-align: center; border-collapse: collapse;"> <tr> <td style="border: none;">F</td><td style="border: none;">E</td><td style="border: none;">D</td><td style="border: none;">C</td><td style="border: none;">B</td><td style="border: none;">A</td><td style="border: none;">9</td><td style="border: none;">8</td> </tr> <tr> <td style="border: 1px solid black;">ostp</td><td style="border: 1px solid black;">orze</td><td style="border: 1px solid black;">ksft</td><td style="border: 1px solid black;">gchg</td><td style="border: 1px solid black;"></td><td style="border: 1px solid black;">ips2</td><td style="border: 1px solid black;">zdir</td><td style="border: 1px solid black;"></td> </tr> </table> <table style="width: 100%; text-align: center; border-collapse: collapse;"> <tr> <td style="border: none;">7</td><td style="border: none;">6</td><td style="border: none;">5</td><td style="border: none;">4</td><td style="border: none;">3</td><td style="border: none;">2</td><td style="border: none;">1</td><td style="border: none;">0</td> </tr> <tr> <td style="border: 1px solid black;">vg8x</td><td style="border: 1px solid black;">mdir</td><td style="border: 1px solid black;">fdir</td><td style="border: 1px solid black;">osc1</td><td style="border: 1px solid black;">pyfx</td><td style="border: 1px solid black;">dmin</td><td style="border: 1px solid black;">odi2</td><td style="border: 1px solid black;">odi1</td> </tr> </table> <p><b>(Note)</b> Always set "0" for the empty bits.</p> <table border="1" style="width: 100%; border-collapse: collapse;"> <thead> <tr> <th style="width: 5%;">bit</th> <th style="width: 15%;">Name</th> <th style="width: 35%;">Meaning when set to 0</th> <th style="width: 45%;">Meaning when set to 1</th> </tr> </thead> <tbody> <tr> <td>0</td> <td>odi1</td> <td colspan="2">Oriented rotary direction</td> </tr> <tr> <td rowspan="2">1</td> <td>odi2</td> <td colspan="2">00: Previous (the direction in which the motor has so far rotated under speed control)</td> </tr> <tr> <td></td> <td colspan="2">01: Forward rotation 10: Backward rotation 11: Prohibited (Same as setting value = 10)</td> </tr> <tr> <td>2</td> <td>dmin</td> <td>Orientation in-position advance invalid</td> <td>Orientation in-position advance valid</td> </tr> <tr> <td>3</td> <td>pyfx</td> <td>Excitation min. (50%) during orientation servo lock invalid</td> <td>Excitation min. (50%) during orientation servo lock valid</td> </tr> <tr> <td>4</td> <td>osc1</td> <td colspan="2">Fixed control bit</td> </tr> <tr> <td>5</td> <td>fdir</td> <td>Encoder detector polarity: +</td> <td>Encoder detector polarity: -</td> </tr> <tr> <td>6</td> <td>mdir</td> <td colspan="2">Fixed control bit</td> </tr> <tr> <td>7</td> <td>vg8x</td> <td colspan="2">Fixed control bit</td> </tr> <tr> <td>8</td> <td></td> <td colspan="2">Fixed control bit</td> </tr> <tr> <td>9</td> <td>zdir</td> <td colspan="2">Fixed control bit</td> </tr> <tr> <td>A</td> <td>ips2</td> <td>2nd in-position invalid</td> <td>2nd in-position valid</td> </tr> <tr> <td>B</td> <td></td> <td colspan="2">Fixed control bit</td> </tr> <tr> <td>C</td> <td>gchg</td> <td colspan="2">Fixed control bit</td> </tr> <tr> <td>D</td> <td>ksft</td> <td colspan="2">Fixed control bit</td> </tr> <tr> <td>E</td> <td>orze</td> <td colspan="2">Fixed control bit</td> </tr> <tr> <td>F</td> <td>ostp</td> <td colspan="2">Fixed control bit</td> </tr> </tbody> </table> <table border="1" style="width: 100%; border-collapse: collapse;"> <thead> <tr> <th colspan="4" style="text-align: center;">In-position advance (bit 2)</th> </tr> <tr> <th colspan="2"></th> <th style="text-align: center;">0 (invalid)</th> <th style="text-align: center;">1 (valid)</th> </tr> </thead> <tbody> <tr> <td rowspan="2" style="writing-mode: vertical-rl; transform: rotate(180deg);">Second position</td> <td style="text-align: center;">0 (Invalid)</td> <td>In-position signal in OINP width=1 Control output 4/ bit 4=1 Second in-position signal=0 Control output 4/ bit F=1</td> <td>In-position signal in OINP width=1 Control output 4/ bit 4=1 Second in-position signal=0 Control output 4/ bit F=0</td> </tr> <tr> <td style="text-align: center;">1 (Valid)</td> <td></td> <td>In-position signal in OINP width=1 Control output 4/ bit 4=1 Second in-position signal=0 Control output 4/ bit F=0</td> </tr> </tbody> </table>	F	E	D	C	B	A	9	8	ostp	orze	ksft	gchg		ips2	zdir		7	6	5	4	3	2	1	0	vg8x	mdir	fdir	osc1	pyfx	dmin	odi2	odi1	bit	Name	Meaning when set to 0	Meaning when set to 1	0	odi1	Oriented rotary direction		1	odi2	00: Previous (the direction in which the motor has so far rotated under speed control)			01: Forward rotation 10: Backward rotation 11: Prohibited (Same as setting value = 10)		2	dmin	Orientation in-position advance invalid	Orientation in-position advance valid	3	pyfx	Excitation min. (50%) during orientation servo lock invalid	Excitation min. (50%) during orientation servo lock valid	4	osc1	Fixed control bit		5	fdir	Encoder detector polarity: +	Encoder detector polarity: -	6	mdir	Fixed control bit		7	vg8x	Fixed control bit		8		Fixed control bit		9	zdir	Fixed control bit		A	ips2	2nd in-position invalid	2nd in-position valid	B		Fixed control bit		C	gchg	Fixed control bit		D	ksft	Fixed control bit		E	orze	Fixed control bit		F	ostp	Fixed control bit		In-position advance (bit 2)						0 (invalid)	1 (valid)	Second position	0 (Invalid)	In-position signal in OINP width=1 Control output 4/ bit 4=1 Second in-position signal=0 Control output 4/ bit F=1	In-position signal in OINP width=1 Control output 4/ bit 4=1 Second in-position signal=0 Control output 4/ bit F=0	1 (Valid)		In-position signal in OINP width=1 Control output 4/ bit 4=1 Second in-position signal=0 Control output 4/ bit F=0		
F	E	D	C	B	A	9	8																																																																																																																			
ostp	orze	ksft	gchg		ips2	zdir																																																																																																																				
7	6	5	4	3	2	1	0																																																																																																																			
vg8x	mdir	fdir	osc1	pyfx	dmin	odi2	odi1																																																																																																																			
bit	Name	Meaning when set to 0	Meaning when set to 1																																																																																																																							
0	odi1	Oriented rotary direction																																																																																																																								
1	odi2	00: Previous (the direction in which the motor has so far rotated under speed control)																																																																																																																								
		01: Forward rotation 10: Backward rotation 11: Prohibited (Same as setting value = 10)																																																																																																																								
2	dmin	Orientation in-position advance invalid	Orientation in-position advance valid																																																																																																																							
3	pyfx	Excitation min. (50%) during orientation servo lock invalid	Excitation min. (50%) during orientation servo lock valid																																																																																																																							
4	osc1	Fixed control bit																																																																																																																								
5	fdir	Encoder detector polarity: +	Encoder detector polarity: -																																																																																																																							
6	mdir	Fixed control bit																																																																																																																								
7	vg8x	Fixed control bit																																																																																																																								
8		Fixed control bit																																																																																																																								
9	zdir	Fixed control bit																																																																																																																								
A	ips2	2nd in-position invalid	2nd in-position valid																																																																																																																							
B		Fixed control bit																																																																																																																								
C	gchg	Fixed control bit																																																																																																																								
D	ksft	Fixed control bit																																																																																																																								
E	orze	Fixed control bit																																																																																																																								
F	ostp	Fixed control bit																																																																																																																								
In-position advance (bit 2)																																																																																																																										
		0 (invalid)	1 (valid)																																																																																																																							
Second position	0 (Invalid)	In-position signal in OINP width=1 Control output 4/ bit 4=1 Second in-position signal=0 Control output 4/ bit F=1	In-position signal in OINP width=1 Control output 4/ bit 4=1 Second in-position signal=0 Control output 4/ bit F=0																																																																																																																							
	1 (Valid)		In-position signal in OINP width=1 Control output 4/ bit 4=1 Second in-position signal=0 Control output 4/ bit F=0																																																																																																																							
3298	SP098	VGOP*	Speed loop gain proportional term in orientation mode	Set the speed loop proportional gain in orientation mode. When the gain is increased, rigidity is improved in the orientation stop but vibration and sound become larger.	0 to 1000 (1/s)	63																																																																																																																				
3299	SP099	VGOI*	Orientation mode speed loop gain integral term	Set the speed loop integral gain in orientation mode.	0 to 1000 (0.1 1/s)	60																																																																																																																				
3300	SP100	VGOD*	Orientation mode speed loop gain delay advance term	Set the a loop gain delay advance gain in orientation mode. When this parameter is set to "0", PI control is exercised.	0 to 1000 (0.1 1/s)	15																																																																																																																				

## 4.8 Spindle Parameters

### 4.8.2 Spindle Parameters

#	Item			Details	Setting range (unit)	Standard setting
3301	SP101	DINP*	Orientation advance in-position width	When using the orientation in-position advance function, set the in-position width that is larger than the normal in-position width defined in SP004 (OINP).	1 to 2880 (1/16°)	16
3302	SP102	OODR*	Excessive error value in orientation mode	Set the excessive error width in orientation mode.	0 to 32767 (1/4 pulse) (1 pulse= 0.088°)	32767
3303	SP103	FTM*	Index positioning completion OFF time timer	Set the time for forcedly turn OFF the index positioning completion signal (different from the orientation completion signal) after the leading edge of the indexing start signal.	1 to 10000 (ms)	200
3304	SP104	TLOR*	Torque limit value for orientation servo locking	Set the torque limit value for orientation in-position output. If the external torque limit signal is input the torque limit value set by this parameter is made invalid.	1 to 120 (%)	100
3305	SP105	IQG0*	Current loop gain magnification 1 in orientation mode	Set the magnification for current loop gain (torque component) at orientation completion.	1 to 1000 (%)	100
3306	SP106	IDG0	Current loop gain magnification 2 in orientation mode	Set the magnification for current loop gain (excitation component) at orientation completion.	1 to 1000 (%)	100
3307	SP107	CSP2	Deceleration rate 2 in orientation mode	Set the deceleration rate in orientation mode corresponding to the gear 001. When this parameter is set to "0", same as SP006 (CSP).	1 to 1000	0
3308	SP108	CSP3	Deceleration rate 3 in orientation mode	Set the deceleration rate in orientation mode corresponding to the gear 010. When this parameter is set to "0", same as SP006 (CSP).	1 to 1000	0
3309	SP109	CSP4*	Deceleration rate 4 in orientation mode	Set the deceleration rate in orientation mode corresponding to the gear 011. When this parameter is set to "0", same as SP006 (CSP).	1 to 1000	0
3310	SP110	WCML*	Turret index command magnification	The integer magnification (gear ratio 1 : N) for the index position command (0 to 359) is set. This parameter is used only with SPJ2.	0 to 32767 (fold)	0
3311	SP111	WDEL	Turret index deceleration magnification	The magnification for the orientation deceleration rate is set using 256 as 1. This parameter is used only with SPJ2.	0 to 32767 (1/256-fold)	0
3312	SP112	WCLP	Turret index clamp speed	The max. speed during indexing is set. This becomes the max. speed of the motor when set to 0. This parameter is used only with SPJ2.	0 to 32767 (r/min)	0
3313	SP113	WINP*	Turret index inposition width	The position error range is set in which an orientation (indexing) completed signal is output during turret indexing. This becomes the same as SP004 (OINP) when set to 0.	0 to 32767 (1/16°)	0

## 4.8 Spindle Parameters

### 4.8.2 Spindle Parameters

#	Item			Details	Setting range (unit)	Standard setting
3314	SP114	OPER	Orientation pulse miss check value	<p><b>For spindle-type servo</b></p> <p>When the pulse miss value during orientation stop is less than the value set here, the orientation operation is completed. Note that a value satisfying the following condition must be set for this parameter.  <math>SP114 \text{ setting value} &gt; 1.5 \times SP004</math>                      (orientation in-position width)</p> <p><b>For others</b></p> <p>An alarm "5C" will occur if the pulse miss value in the orientation stop exceed this setting value. (Note that this is invalid when set to "0".) In this parameter, set the value to fulfill the following conditions.  <math>SP114 \text{ setting value} &gt; 1.5 \times SP004</math>                      (orientation in-position width)</p>	0 to 32767 (360°/4096)	0
3315 to 3318	SP115 to SP118			Set by Mitsubishi. Set "0" unless designated in particular.	0	0
3319	SP119	MPGH	Orientation position gain H winding compensation magnification	<p>Set the compensation magnification of the orientation position loop gain for the H winding.  <math>H \text{ winding orientation position loop gain} = SP001 \text{ (or } SP002) \times SP119/256</math></p> <p>When set to "0", will become the same as SP001 or SP002.</p>	0 to 2560 (1/256-fold)	0
3320	SP120	MPGL	Orientation position gain L winding compensation magnification	<p>Set the compensation magnification of the orientation position loop gain for the L winding.  <math>L \text{ winding orientation position loop gain} = SP001 \text{ (or } SP002) \times SP120/256</math></p> <p>When set to "0", will become the same as SP001 or SP002.</p>	0 to 2560 (1/256-fold)	0
3321	SP121	MPCSH	Orientation deceleration rate H winding compensation magnification	<p>Set the compensation magnification of the orientation deceleration rate for the H winding.  <math>\text{Orientation deceleration rate for the H winding} = SP006 \times SP121/256</math></p> <p>When set to "0", will become the same as SP006.</p>	0 to 2560 (1/256-fold)	0
3322	SP122	MPCSL	Orientation deceleration rate L winding compensation magnification	<p>Set the compensation magnification of the orientation deceleration rate for the L winding.  <math>\text{Orientation deceleration rate for the L winding} = SP006 \times SP122/256</math></p> <p>When set to "0", will become the same as SP006.</p>	0 to 2560 (1/256-fold)	0
3323	SP123	MGDO	Magnetic detector output peak value	<p>This parameter is used for adjustment of orientation operation of the magnetic detector. Set the output peak value of the magnetic detector.</p> <p>If a gap between the detector and the magnetizing element is small, increase the value of this parameter. If it is large, decrease the value of this parameter.</p>	1 to 10000	Standard magnetizing element: 542 Small magnetizing element: 500

**4.8 Spindle Parameters**  
**4.8.2 Spindle Parameters**

#	Item			Details	Setting range (unit)	Standard setting																																																																																																																
3324	SP124	MGD1	Magnetic detector linear zone width	<p>This parameter is used for adjustment of orientation operation of the magnetic detector. Set the linear zone width of the magnetic detector.</p> <p>If the mounting radius of the magnetizing element is large, decrease the value of this parameter. If it is small, increase the value of this parameter.</p>	1 to 10000	Standard magnetizing element: 768 Small magnetizing element: 440																																																																																																																
3325	SP125	MGD2	Magnetic detector switching point	<p>This parameter is used for adjustment of orientation operation of the magnetic detector. Set the distance dimension from the target stop point at switching from position feedback to magnetic detector output. In common practices, assign a value that is approx. 1/2 of the value defined in SP124.</p>	1 to 10000	Standard magnetizing element: 384 Small magnetizing element: 220																																																																																																																
3326 to 3328	SP126 to SP128			Not used. Set to "0".	0	0																																																																																																																
3329	SP129	SPECC	C-axis specifications	<p><b>For spindle-type servo</b></p> <p>Set the C-axis specifications in bit units.</p> <table style="width: 100%; border-collapse: collapse; text-align: center;"> <tr> <td style="border: none;">F</td><td style="border: none;">E</td><td style="border: none;">D</td><td style="border: none;">C</td><td style="border: none;">B</td><td style="border: none;">A</td><td style="border: none;">9</td><td style="border: none;">8</td> </tr> <tr> <td style="border: 1px solid black; width: 20px;">zrtn</td><td style="border: 1px solid black; width: 20px;">ptyp</td><td style="border: 1px solid black; width: 20px;"></td><td style="border: 1px solid black; width: 20px;">zrtd</td><td style="border: 1px solid black; width: 20px;"></td><td style="border: 1px solid black; width: 20px;"></td><td style="border: 1px solid black; width: 20px;"></td><td style="border: 1px solid black; width: 20px;"></td> </tr> <tr> <td style="border: none;">7</td><td style="border: none;">6</td><td style="border: none;">5</td><td style="border: none;">4</td><td style="border: none;">3</td><td style="border: none;">2</td><td style="border: none;">1</td><td style="border: none;">0</td> </tr> <tr> <td style="border: 1px solid black; width: 20px;"></td><td style="border: 1px solid black; width: 20px;"></td><td style="border: 1px solid black; width: 20px;"></td><td style="border: 1px solid black; width: 20px;"></td><td style="border: 1px solid black; width: 20px;"></td><td style="border: 1px solid black; width: 20px;"></td><td style="border: 1px solid black; width: 20px;"></td><td style="border: 1px solid black; width: 20px;"></td> </tr> </table> <p><b>(Note)</b> Always set "0" for the empty bits.</p> <table border="1" style="width: 100%; border-collapse: collapse; text-align: center;"> <thead> <tr> <th style="width: 5%;">bit</th> <th style="width: 15%;">Name</th> <th style="width: 35%;">Meaning when set to 0</th> <th style="width: 45%;">Meaning when set to 1</th> </tr> </thead> <tbody> <tr><td>0</td><td></td><td></td><td></td></tr> <tr><td>1</td><td></td><td></td><td></td></tr> <tr><td>2</td><td></td><td></td><td></td></tr> <tr><td>3</td><td></td><td></td><td></td></tr> <tr><td>4</td><td></td><td></td><td></td></tr> <tr><td>5</td><td></td><td></td><td></td></tr> <tr><td>6</td><td></td><td></td><td></td></tr> <tr><td>7</td><td></td><td></td><td></td></tr> <tr><td>8</td><td></td><td></td><td></td></tr> <tr><td>9</td><td></td><td></td><td></td></tr> <tr><td>A</td><td></td><td></td><td></td></tr> <tr><td>B</td><td></td><td></td><td></td></tr> <tr> <td>C</td> <td>zrtd</td> <td>Position control changeover: after zero point return</td> <td>Position control changeover: PLC signal control</td> </tr> <tr> <td>D</td> <td></td> <td></td> <td></td> </tr> <tr> <td>E</td> <td>ptyp</td> <td>Position control switch type: Following bit C</td> <td>Position control switch type: After deceleration stop</td> </tr> <tr> <td>F</td> <td>zrtn</td> <td>Zero point return direction: CCW</td> <td>Zero point return direction: CW</td> </tr> </tbody> </table> <table border="1" style="width: 100%; border-collapse: collapse; text-align: center;"> <thead> <tr> <th style="width: 15%;">bit E</th> <th style="width: 15%;">bit C</th> <th style="width: 70%;">Position control changeover</th> </tr> </thead> <tbody> <tr> <td rowspan="2">0</td> <td>0</td> <td>After zero point return</td> </tr> <tr> <td>1</td> <td>Control using PLC signal</td> </tr> <tr> <td rowspan="2">1</td> <td>0</td> <td rowspan="2">After deceleration stop</td> </tr> <tr> <td>1</td> </tr> </tbody> </table>	F	E	D	C	B	A	9	8	zrtn	ptyp		zrtd					7	6	5	4	3	2	1	0									bit	Name	Meaning when set to 0	Meaning when set to 1	0				1				2				3				4				5				6				7				8				9				A				B				C	zrtd	Position control changeover: after zero point return	Position control changeover: PLC signal control	D				E	ptyp	Position control switch type: Following bit C	Position control switch type: After deceleration stop	F	zrtn	Zero point return direction: CCW	Zero point return direction: CW	bit E	bit C	Position control changeover	0	0	After zero point return	1	Control using PLC signal	1	0	After deceleration stop	1	0000 to FFFF HEX setting	0000
F	E	D	C	B	A	9	8																																																																																																															
zrtn	ptyp		zrtd																																																																																																																			
7	6	5	4	3	2	1	0																																																																																																															
bit	Name	Meaning when set to 0	Meaning when set to 1																																																																																																																			
0																																																																																																																						
1																																																																																																																						
2																																																																																																																						
3																																																																																																																						
4																																																																																																																						
5																																																																																																																						
6																																																																																																																						
7																																																																																																																						
8																																																																																																																						
9																																																																																																																						
A																																																																																																																						
B																																																																																																																						
C	zrtd	Position control changeover: after zero point return	Position control changeover: PLC signal control																																																																																																																			
D																																																																																																																						
E	ptyp	Position control switch type: Following bit C	Position control switch type: After deceleration stop																																																																																																																			
F	zrtn	Zero point return direction: CCW	Zero point return direction: CW																																																																																																																			
bit E	bit C	Position control changeover																																																																																																																				
0	0	After zero point return																																																																																																																				
	1	Control using PLC signal																																																																																																																				
1	0	After deceleration stop																																																																																																																				
	1																																																																																																																					

**4.8 Spindle Parameters**  
**4.8.2 Spindle Parameters**

#	Item		Details	Setting range (unit)	Standard setting																																																																																																				
3329	SP129	SPECC	C-axis specifications  <b>For others</b> Set the C-axis specifications in bit units. <table style="width: 100%; text-align: center; border-collapse: collapse;"> <tr> <td style="border: none;">F</td><td style="border: none;">E</td><td style="border: none;">D</td><td style="border: none;">C</td><td style="border: none;">B</td><td style="border: none;">A</td><td style="border: none;">9</td><td style="border: none;">8</td> </tr> <tr> <td style="border: 1px solid black;">zrtn</td><td style="border: 1px solid black;">ptyp</td><td style="border: 1px solid black;">fb9x</td><td style="border: 1px solid black;">zrtd</td><td style="border: 1px solid black;">zrn2</td><td style="border: 1px solid black;"></td><td style="border: 1px solid black;">zdir</td><td style="border: 1px solid black;">ztyp</td> </tr> <tr> <td style="border: none;">7</td><td style="border: none;">6</td><td style="border: none;">5</td><td style="border: none;">4</td><td style="border: none;">3</td><td style="border: none;">2</td><td style="border: none;">1</td><td style="border: none;">0</td> </tr> <tr> <td style="border: 1px solid black;">vg8x</td><td style="border: 1px solid black;"></td><td style="border: 1px solid black;">fdir</td><td style="border: 1px solid black;"></td><td style="border: 1px solid black;"></td><td style="border: 1px solid black;"></td><td style="border: 1px solid black;">adin</td><td style="border: 1px solid black;">fclx</td> </tr> </table> <p><b>(Note)</b> Always set "0" for the empty bits.</p> <table border="1" style="width: 100%; border-collapse: collapse;"> <thead> <tr> <th>bit</th> <th>Name</th> <th>Meaning when set to 0</th> <th>Meaning when set to 1</th> </tr> </thead> <tbody> <tr> <td>0</td> <td>fclx</td> <td>Closed loop</td> <td>Semi-closed loop (Gear 1 : 1 only)</td> </tr> <tr> <td>1</td> <td>adin</td> <td>Interpolation A/D compensation invalid</td> <td>Interpolation A/D compensation valid</td> </tr> <tr> <td>2</td> <td></td> <td></td> <td></td> </tr> <tr> <td>3</td> <td></td> <td></td> <td></td> </tr> <tr> <td>4</td> <td></td> <td></td> <td></td> </tr> <tr> <td>5</td> <td>fdir</td> <td>Position detector direction (positive)</td> <td>Position detector direction (negative)</td> </tr> <tr> <td>6</td> <td></td> <td></td> <td></td> </tr> <tr> <td>7</td> <td>vg8x</td> <td>Speed gain × 1/8 during torque limit valid</td> <td>Speed gain × 1/8 during torque limit invalid</td> </tr> <tr> <td>8</td> <td>ztyp</td> <td>Z-phase type: Normal start up</td> <td>Z-phase type: Start up only</td> </tr> <tr> <td>9</td> <td>zdir</td> <td>Z-phase rising polarity (+)</td> <td>Z-phase rising polarity (-)</td> </tr> <tr> <td>A</td> <td></td> <td></td> <td></td> </tr> <tr> <td>B</td> <td>zrn2</td> <td>Fixed control bit</td> <td></td> </tr> <tr> <td>C</td> <td>zrtd</td> <td>Fixed control bit</td> <td></td> </tr> <tr> <td>D</td> <td>fb9x</td> <td>Speed feedback Standard (PLG)</td> <td>Speed feedback 90,000 pulse detector</td> </tr> <tr> <td>E</td> <td>ptyp</td> <td>Position control switch type: After zero point return</td> <td>Position control switch type: After deceleration stop</td> </tr> <tr> <td>F</td> <td>zrtn</td> <td>Zero point return direction: CCW</td> <td>Zero point return direction: CW</td> </tr> </tbody> </table>	F	E	D	C	B	A	9	8	zrtn	ptyp	fb9x	zrtd	zrn2		zdir	ztyp	7	6	5	4	3	2	1	0	vg8x		fdir				adin	fclx	bit	Name	Meaning when set to 0	Meaning when set to 1	0	fclx	Closed loop	Semi-closed loop (Gear 1 : 1 only)	1	adin	Interpolation A/D compensation invalid	Interpolation A/D compensation valid	2				3				4				5	fdir	Position detector direction (positive)	Position detector direction (negative)	6				7	vg8x	Speed gain × 1/8 during torque limit valid	Speed gain × 1/8 during torque limit invalid	8	ztyp	Z-phase type: Normal start up	Z-phase type: Start up only	9	zdir	Z-phase rising polarity (+)	Z-phase rising polarity (-)	A				B	zrn2	Fixed control bit		C	zrtd	Fixed control bit		D	fb9x	Speed feedback Standard (PLG)	Speed feedback 90,000 pulse detector	E	ptyp	Position control switch type: After zero point return	Position control switch type: After deceleration stop	F	zrtn	Zero point return direction: CCW	Zero point return direction: CW		0000
F	E	D	C	B	A	9	8																																																																																																		
zrtn	ptyp	fb9x	zrtd	zrn2		zdir	ztyp																																																																																																		
7	6	5	4	3	2	1	0																																																																																																		
vg8x		fdir				adin	fclx																																																																																																		
bit	Name	Meaning when set to 0	Meaning when set to 1																																																																																																						
0	fclx	Closed loop	Semi-closed loop (Gear 1 : 1 only)																																																																																																						
1	adin	Interpolation A/D compensation invalid	Interpolation A/D compensation valid																																																																																																						
2																																																																																																									
3																																																																																																									
4																																																																																																									
5	fdir	Position detector direction (positive)	Position detector direction (negative)																																																																																																						
6																																																																																																									
7	vg8x	Speed gain × 1/8 during torque limit valid	Speed gain × 1/8 during torque limit invalid																																																																																																						
8	ztyp	Z-phase type: Normal start up	Z-phase type: Start up only																																																																																																						
9	zdir	Z-phase rising polarity (+)	Z-phase rising polarity (-)																																																																																																						
A																																																																																																									
B	zrn2	Fixed control bit																																																																																																							
C	zrtd	Fixed control bit																																																																																																							
D	fb9x	Speed feedback Standard (PLG)	Speed feedback 90,000 pulse detector																																																																																																						
E	ptyp	Position control switch type: After zero point return	Position control switch type: After deceleration stop																																																																																																						
F	zrtn	Zero point return direction: CCW	Zero point return direction: CW																																																																																																						
3330	SP130	PGC1	First position loop gain for cutting on C-axis	Set the position loop gain when the first gain is selected for C axis cutting.	1 to 100 (1/s)	15																																																																																																			
3331	SP131	PGC2	Second position loop gain for cutting on C-axis	Set the position loop gain when the second gain is selected for C axis cutting.	1 to 100 (1/s)	15																																																																																																			
3332	SP132	PGC3	Third position loop gain for cutting on C-axis	Set the position loop gain when the third gain is selected for C-axis cutting.	1 to 100 (1/s)	15																																																																																																			
3333	SP133	PGC4	Stop position loop gain for cutting on C-axis	Set the position loop gain for stopping when carrying out C-axis cutting.	1 to 100 (1/s)	15																																																																																																			
3334	SP134	VGCP0	C-axis non-cutting speed loop gain proportional item	Set the speed loop proportional gain in C-axis non-cutting mode.	0 to 5000 (1/s)	63																																																																																																			



## 4.8 Spindle Parameters

### 4.8.2 Spindle Parameters

#	Item		Details	Setting range (unit)	Standard setting	
3335	SP135	VGCI0*	C-axis non-cutting speed loop gain integral item	Set the speed loop integral gain in C-axis non-cutting mode.	0 to 5000 (0.1 1/s)	60
3336	SP136	VGCD0*	C-axis non-cutting speed loop gain delay advance item	Set the speed loop delay advance gain in C-axis non-cutting mode. When this parameter is set to "0", PI control is exercised.	0 to 5000 (0.1 1/s)	15
3337	SP137	VGCP1*	First speed loop gain proportional item for C-axis cutting	Set the speed loop proportional gain when the first gain is selected for C-axis cutting.	0 to 5000 (1/s)	63
3338	SP138	VGCI1*	First speed loop gain integral item for cutting on C-axis	Set the speed loop integral gain when the first gain is selected for C-axis cutting.	0 to 5000 (0.1 1/s)	60
3339	SP139	VGCD1*	First speed loop gain delay advance item for cutting on C-axis	Set the speed loop delay advance gain when the first gain is selected for curing on the C-axis. When this parameter is set to "0", PI control is exercised.	0 to 5000 (0.1 1/s)	15
3340	SP140	VGCP2*	Second speed loop gain proportional item for cutting on C-axis	Set the speed loop proportional gain when the second gain is selected for C-axis cutting.	0 to 5000 (1/s)	63
3341	SP141	VGCI2*	Second speed loop gain integral item for cutting on C-axis	Set the speed loop integral gain when the second gain is selected for C-axis cutting.	0 to 5000 (0.1 1/s)	60
3342	SP142	VGCD2*	Second speed loop gain delay advance item for cutting on C-axis	Set the speed loop delay advance gain when the second gain is selected for C-axis cutting. When this parameter is set to "0", PI control is exercised.	0 to 5000 (0.1 1/s)	15
3343	SP143	VGCP3*	Third speed loop gain proportional item for cutting on C-axis	Set the speed loop proportional gain when the third gain is selected for C-axis cutting.	0 to 5000 (1/s)	63
3344	SP144	VGCI3*	Third speed loop gain integral item for cutting on C-axis	Set the speed loop integral gain when the third gain is selected for C-axis cutting.	0 to 5000 (0.1 1/s)	60

## 4.8 Spindle Parameters

### 4.8.2 Spindle Parameters

#	Item		Details	Setting range (unit)	Standard setting	
3345	SP145	VGCD3*	Third speed loop gain delay advance item for cutting on C-axis	Set the speed loop delay advance gain when the third gain is selected for C-axis cutting. When this parameter is set to "0", PI control is exercised.	0 to 5000 (0.1 1/s)	15
3346	SP146	VGCP4*	Speed loop gain proportional item for stop of cutting on C-axis	Set the speed loop proportional gain when C-axis cutting is stopped.	0 to 5000 (1/s)	63
3347	SP147	VGCI4*	Speed loop gain integral item for stop of cutting on C-axis	Set the speed loop integral gain when C-axis cutting is stopped.	0 to 5000 (0.1 1/s)	60
3348	SP148	VGCD4*	Speed loop gain delay advance item for stop of cutting on C-axis	Set the speed loop delay advance gain when C-axis cutting is stopped. When this parameter is set to "0", PI control is exercised.	0 to 5000 (0.1 1/s)	15
3349	SP149	CZRN	C-axis zero point return speed	This parameter is valid when SP129 (SPECC) bitE is set to "0". Set the zero point return speed used when the speed loop changes to the position loop.	1 to 500 (r/min)	50
3350	SP150	CPDT	C-axis zero point return deceleration point	This parameter is valid when SP129 (SPECC) bitE is set to "0". Set the deceleration rate where the machine starts to decelerate when it returns to the target stop point during C-axis zero point return. When the machine tends to overshoot at the stop point, set the smaller value.	1 to 10000	1
3351	SP151	CPSTL	C-axis zero point return shift amount (low byte)	This parameter is valid when SPECC (SP129) bitE is set to "0". Set the C-axis zero point position.	HEX setting 00000000 to FFFFFFFF (1/1000°)	H: 0000 L: 0000
3352	SP152	CPSTH	C-axis zero point return shift amount (high byte)			
3353	SP153	CINP	C-axis in-position width	Set the position error range in which the in-position signal is output on the C-axis.	0000 to FFFF (1/1000°) HEX setting	03E8
3354	SP154	CODRL*	Excessive error width on C-axis (low byte)	Set the excessive error width on the C-axis.	HEX setting 00000000 to FFFFFFFF (1/1000°)	H: 0001 L: D4C0
3355	SP155	CODRH*	Excessive error width on C-axis (high byte)			
3356 to 3358	SP156 to SP158			Not used. Set to "0".	0	0

## 4.8 Spindle Parameters

### 4.8.2 Spindle Parameters

#	Item			Details	Setting range (unit)	Standard setting
3359	SP159	CPY0*	C-axis non-cutting variable excitation ratio	Set the minimum value of variable excitation ratio for non-cutting on the C-axis .	0 to 100 (%)	50
3360	SP160	CPY1*	C-axis cutting variable excitation ratio	Set the minimum variable excitation ratio for cutting mode on the C-axis.	0 to 100 (%)	100
3361	SP161	IQGC0*	Current loop gain magnification 1 for non-cutting on C-axis	Set the magnification of current loop gain (torque component) for C-axis non-cutting.	1 to 1000 (%)	100
3362	SP162	IDGC0*	Current loop gain magnification 2 for non-cutting on C-axis	Set the magnification of current loop gain (excitation component) for C-axis non-cutting.	1 to 1000 (%)	100
3363	SP163	IQGC1*	Current loop gain magnification 1 for cutting on C-axis	Set the magnification of current loop gain (torque component) for C-axis cutting.	1 to 1000 (%)	100
3364	SP164	IDGC1*	Current loop gain magnification 2 for cutting on C-axis	Set the magnification of current loop gain (excitation component) for C-axis cutting.	1 to 1000 (%)	100
3365	SP165	PG2C	C-axis position loop gain 2	Set the second position loop gain when high-gain control is carried out for control of the C-axis. This parameter is applied to all the operation modes of C-axis control. When this function is not used, assign "0".	0 to 999 (1/s)	0
3366	SP166	PG3C	C-axis position loop gain 3	Set the third position loop gain when high-gain control is carried out for control of the C-axis. This parameter is applied to all the operation modes of C-axis control. When this function is not used, assign "0".	0 to 999 (1/s)	0
3367	SP167	PGU*	Position loop gain for increased spindle holding force	Set the position loop gain for when the disturbance observer is valid.	0 to 100 (1/s)	15
3368	SP168	VGUP*	Speed loop gain proportional item for increased spindle holding force	Set the speed loop gain proportional item for when the disturbance observer is valid.	0 to 5000 (1/s)	63
3369	SP169	VGUI*	Speed loop gain integral item for increased spindle holding force	Set the speed loop gain integral item for when the disturbance observer is valid.	0 to 5000 (0.1 1/s)	60

**4.8 Spindle Parameters**  
**4.8.2 Spindle Parameters**

#	Item	Details	Setting range (unit)	Standard setting																																																																																																																																																																								
3370	SP170	VGUD* Speed loop gain delay advance item for increased spindle holding force	0 to 5000 (0.1 1/s)	15																																																																																																																																																																								
3371 to 3376	SP171 to SP176	Not used. Set to "0".	0	0																																																																																																																																																																								
3377	SP177	SPECS* Spindle synchronous specifications	0000 to FFFF HEX setting	0000																																																																																																																																																																								
<p><b>For SPJ2</b></p> <p>Set the spindle synchronous specifications in bit units.</p> <table style="width: 100%; text-align: center; border-collapse: collapse;"> <tr> <td style="border: 1px solid black; width: 12.5%;">F</td> <td style="border: 1px solid black; width: 12.5%;">E</td> <td style="border: 1px solid black; width: 12.5%;">D</td> <td style="border: 1px solid black; width: 12.5%;">C</td> <td style="border: 1px solid black; width: 12.5%;">B</td> <td style="border: 1px solid black; width: 12.5%;">A</td> <td style="border: 1px solid black; width: 12.5%;">9</td> <td style="border: 1px solid black; width: 12.5%;">8</td> </tr> <tr> <td style="border: 1px solid black; height: 15px;"></td> <td style="border: 1px solid black; height: 15px;"></td> <td style="border: 1px solid black; height: 15px;">odx8</td> <td style="border: 1px solid black; height: 15px;"></td> <td style="border: 1px solid black; height: 15px;"></td> <td style="border: 1px solid black; height: 15px;"></td> <td style="border: 1px solid black; height: 15px;"></td> <td style="border: 1px solid black; height: 15px;"></td> </tr> <tr> <td style="border: 1px solid black; width: 12.5%;">7</td> <td style="border: 1px solid black; width: 12.5%;">6</td> <td style="border: 1px solid black; width: 12.5%;">5</td> <td style="border: 1px solid black; width: 12.5%;">4</td> <td style="border: 1px solid black; width: 12.5%;">3</td> <td style="border: 1px solid black; width: 12.5%;">2</td> <td style="border: 1px solid black; width: 12.5%;">1</td> <td style="border: 1px solid black; width: 12.5%;">0</td> </tr> <tr> <td style="border: 1px solid black; height: 15px;"></td> <td style="border: 1px solid black; height: 15px;"></td> <td style="border: 1px solid black; height: 15px;">fdir</td> <td style="border: 1px solid black; height: 15px;"></td> <td style="border: 1px solid black; height: 15px;">pyfx</td> <td style="border: 1px solid black; height: 15px;"></td> <td style="border: 1px solid black; height: 15px;">adin</td> <td style="border: 1px solid black; height: 15px;">fclx</td> </tr> </table> <p><b>(Note)</b> Always set "0" for the empty bits.</p> <table border="1" style="width: 100%; border-collapse: collapse;"> <thead> <tr> <th style="width: 5%;">bit</th> <th style="width: 15%;">Name</th> <th style="width: 40%;">Meaning when set to 0</th> <th style="width: 40%;">Meaning when set to 1</th> </tr> </thead> <tbody> <tr><td>0</td><td>fclx</td><td>Closed loop</td><td>Semi-closed loop</td></tr> <tr><td>1</td><td></td><td></td><td></td></tr> <tr><td>2</td><td></td><td></td><td></td></tr> <tr><td>3</td><td>pyfx</td><td>Normal excitation</td><td>Position loop excitation fixed (strong)</td></tr> <tr><td>4</td><td></td><td></td><td></td></tr> <tr><td>5</td><td>fdir</td><td>Position detector direction (+)</td><td>Position detector direction (-)</td></tr> <tr><td>6</td><td></td><td></td><td></td></tr> <tr><td>7</td><td></td><td></td><td></td></tr> <tr><td>8</td><td></td><td></td><td></td></tr> <tr><td>9</td><td></td><td></td><td></td></tr> <tr><td>A</td><td></td><td></td><td></td></tr> <tr><td>B</td><td></td><td></td><td></td></tr> <tr><td>C</td><td></td><td></td><td></td></tr> <tr><td>D</td><td>odx8</td><td>Magnification of excessive error width x 8 times invalid</td><td>Magnification of excessive error width x 8 times valid</td></tr> <tr><td>E</td><td></td><td></td><td></td></tr> <tr><td>F</td><td></td><td></td><td></td></tr> </tbody> </table> <p><b>For others</b></p> <p>Set the spindle synchronous specifications in bit units.</p> <table border="1" style="width: 100%; border-collapse: collapse;"> <thead> <tr> <th style="width: 5%;">bit</th> <th style="width: 15%;">Name</th> <th style="width: 40%;">Meaning when set to 0</th> <th style="width: 40%;">Meaning when set to 1</th> </tr> </thead> <tbody> <tr><td>0</td><td>fclx</td><td>Closed loop</td><td>Semi-closed loop</td></tr> <tr><td>1</td><td>adin</td><td>Interpolation A/D compensation invalid</td><td>Interpolation A/D compensation valid</td></tr> <tr><td>2</td><td></td><td></td><td></td></tr> <tr><td>3</td><td>pyfx</td><td>Normal excitation</td><td>Position loop excitation fixed (strong)</td></tr> <tr><td>4</td><td></td><td></td><td></td></tr> <tr><td>5</td><td>fdir</td><td>Position detector direction (+)</td><td>Position detector direction (-)</td></tr> <tr><td>6</td><td></td><td></td><td></td></tr> <tr><td>7</td><td></td><td></td><td></td></tr> <tr><td>8</td><td></td><td></td><td></td></tr> <tr><td>9</td><td></td><td></td><td></td></tr> <tr><td>A</td><td></td><td></td><td></td></tr> <tr><td>B</td><td></td><td></td><td></td></tr> <tr><td>C</td><td></td><td></td><td></td></tr> <tr><td>D</td><td>odx8</td><td>Magnification of excessive error width x 8 times invalid</td><td>Magnification of excessive error width x 8 times valid</td></tr> <tr><td>E</td><td></td><td></td><td></td></tr> <tr><td>F</td><td></td><td>(Used with SPJ)</td><td></td></tr> </tbody> </table>					F	E	D	C	B	A	9	8			odx8						7	6	5	4	3	2	1	0			fdir		pyfx		adin	fclx	bit	Name	Meaning when set to 0	Meaning when set to 1	0	fclx	Closed loop	Semi-closed loop	1				2				3	pyfx	Normal excitation	Position loop excitation fixed (strong)	4				5	fdir	Position detector direction (+)	Position detector direction (-)	6				7				8				9				A				B				C				D	odx8	Magnification of excessive error width x 8 times invalid	Magnification of excessive error width x 8 times valid	E				F				bit	Name	Meaning when set to 0	Meaning when set to 1	0	fclx	Closed loop	Semi-closed loop	1	adin	Interpolation A/D compensation invalid	Interpolation A/D compensation valid	2				3	pyfx	Normal excitation	Position loop excitation fixed (strong)	4				5	fdir	Position detector direction (+)	Position detector direction (-)	6				7				8				9				A				B				C				D	odx8	Magnification of excessive error width x 8 times invalid	Magnification of excessive error width x 8 times valid	E				F		(Used with SPJ)	
F	E	D	C	B	A	9	8																																																																																																																																																																					
		odx8																																																																																																																																																																										
7	6	5	4	3	2	1	0																																																																																																																																																																					
		fdir		pyfx		adin	fclx																																																																																																																																																																					
bit	Name	Meaning when set to 0	Meaning when set to 1																																																																																																																																																																									
0	fclx	Closed loop	Semi-closed loop																																																																																																																																																																									
1																																																																																																																																																																												
2																																																																																																																																																																												
3	pyfx	Normal excitation	Position loop excitation fixed (strong)																																																																																																																																																																									
4																																																																																																																																																																												
5	fdir	Position detector direction (+)	Position detector direction (-)																																																																																																																																																																									
6																																																																																																																																																																												
7																																																																																																																																																																												
8																																																																																																																																																																												
9																																																																																																																																																																												
A																																																																																																																																																																												
B																																																																																																																																																																												
C																																																																																																																																																																												
D	odx8	Magnification of excessive error width x 8 times invalid	Magnification of excessive error width x 8 times valid																																																																																																																																																																									
E																																																																																																																																																																												
F																																																																																																																																																																												
bit	Name	Meaning when set to 0	Meaning when set to 1																																																																																																																																																																									
0	fclx	Closed loop	Semi-closed loop																																																																																																																																																																									
1	adin	Interpolation A/D compensation invalid	Interpolation A/D compensation valid																																																																																																																																																																									
2																																																																																																																																																																												
3	pyfx	Normal excitation	Position loop excitation fixed (strong)																																																																																																																																																																									
4																																																																																																																																																																												
5	fdir	Position detector direction (+)	Position detector direction (-)																																																																																																																																																																									
6																																																																																																																																																																												
7																																																																																																																																																																												
8																																																																																																																																																																												
9																																																																																																																																																																												
A																																																																																																																																																																												
B																																																																																																																																																																												
C																																																																																																																																																																												
D	odx8	Magnification of excessive error width x 8 times invalid	Magnification of excessive error width x 8 times valid																																																																																																																																																																									
E																																																																																																																																																																												
F		(Used with SPJ)																																																																																																																																																																										

## 4.8 Spindle Parameters

### 4.8.2 Spindle Parameters

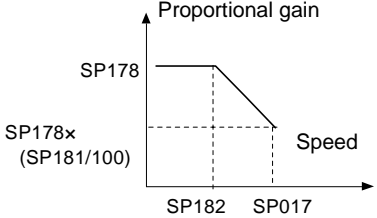
#	Item		Details	Setting range (unit)	Standard setting	
3378	SP178	VGSP*	Spindle synchronous speed loop gain proportional term	Set the speed loop proportional gain in spindle synchronization mode.	0 to 1000 (1/s)	63
3379	SP179	VGSI*	Spindle synchronous speed loop gain integral term	Set the speed loop integral gain in spindle synchronization mode.	0 to 1000 (0.1 1/s)	60
3380	SP180	VGSD*	Spindle synchronous speed loop gain delay advance term	Set the speed loop delay advance gain in spindle synchronization mode. When this parameter is set to "0", PI control is exercised.	0 to 1000 (0.1 1/s)	15
3381	SP181	VCGS*	Target value of variable speed loop proportional gain at spindle synchronization	Set the magnification of speed loop proportional gain with respect to SP178 (VGSP) at the maximum speed defined in SP017 (TSP) at spindle synchronization.	0 to 100 (%)	100
3382	SP182	VCSS*	Change starting speed of variable speed loop proportional gain at spindle synchronization	Set the speed for starting change of speed loop proportional gain at spindle synchronization. 	0 to 32767 (r/min)	0
3383	SP183	SYNV	Sync matching speed at spindle synchronization	For changeover from the speed loop to the position loop at spindle synchronization, set a speed command error range for output of the sync speed matching signal.	0 to 1000 (r/min)	20
3384	SP184	FFCS*	Acceleration rate feed forward gain at spindle synchronization	Set the acceleration rate feed forward gain at spindle synchronization. This parameter is used only with the SPJ2.	0 to 1000 (%)	0
3385	SP185	SINP	Spindle sync in-position width	Set the position error range for output of the in-position signal at spindle synchronization.	1 to 2880 (1/16°)	16
3386	SP186	SODR*	Excessive error width at spindle synchronization	Set the excessive error width at spindle synchronization.	1 to 32767 (pulse) (1 pulse = 0.088°)	32767
3387	SP187	IQGS*	Current loop gain magnification1 at spindle synchronization	Set the magnification of current loop gain (torque component) at spindle synchronization.	1 to 1000 (%)	100

**4.8 Spindle Parameters**  
**4.8.2 Spindle Parameters**

#	Item	Details	Setting range (unit)	Standard setting																																																																																																					
3388	SP188	IDGS* Current loop gain magnification 2 at spindle synchronization	Set the magnification of current loop gain (excitation component) at spindle synchronization.	1 to 1000 (%)	100																																																																																																				
3389	SP189	PG2S Position loop gain 2 at spindle synchronization	Set the second position loop gain when high-gain control is carried out at spindle synchronization. When this parameter function is not used, set to "0".	0 to 999 (1/s)	0																																																																																																				
3390	SP190	PG3S Position loop gain 3 at spindle synchronization	Set the third position loop gain when high-gain control is carried out at spindle synchronization. When this parameter function is not used, set to "0".	0 to 999 (1/s)	0																																																																																																				
3391 to 3392	SP191 to SP192		Not used. Set to "0".	0	0																																																																																																				
3393	SP193	SPECT* Synchronous tapping specifications	<p><b>For SPJ2</b></p> <p>Set the synchronous tapping specifications in bit units.</p> <table style="width: 100%; border-collapse: collapse; margin-bottom: 10px;"> <tr> <td style="text-align: center;">F</td><td style="text-align: center;">E</td><td style="text-align: center;">D</td><td style="text-align: center;">C</td><td style="text-align: center;">B</td><td style="text-align: center;">A</td><td style="text-align: center;">9</td><td style="text-align: center;">8</td> </tr> <tr> <td style="text-align: center;">zrtn</td><td style="text-align: center;">ptyp</td><td style="text-align: center;">od8x</td><td style="text-align: center;"></td><td style="text-align: center;"></td><td style="text-align: center;"></td><td style="text-align: center;"></td><td style="text-align: center;"></td> </tr> </table> <table style="width: 100%; border-collapse: collapse; margin-bottom: 10px;"> <tr> <td style="text-align: center;">7</td><td style="text-align: center;">6</td><td style="text-align: center;">5</td><td style="text-align: center;">4</td><td style="text-align: center;">3</td><td style="text-align: center;">2</td><td style="text-align: center;">1</td><td style="text-align: center;">0</td> </tr> <tr> <td style="text-align: center;"></td><td style="text-align: center;"></td><td style="text-align: center;">fdir</td><td style="text-align: center;">cdir</td><td style="text-align: center;">pyfx</td><td style="text-align: center;"></td><td style="text-align: center;"></td><td style="text-align: center;">fclx</td> </tr> </table> <p><b>(Note)</b> Always set "0" for the empty bits.</p> <table border="1" style="width: 100%; border-collapse: collapse; margin-bottom: 10px;"> <thead> <tr> <th style="text-align: center;">bit</th> <th style="text-align: center;">Name</th> <th style="text-align: center;">Meaning when set to 0</th> <th style="text-align: center;">Meaning when set to 1</th> </tr> </thead> <tbody> <tr> <td style="text-align: center;">0</td> <td style="text-align: center;">fclx</td> <td style="text-align: center;">Closed loop</td> <td style="text-align: center;">Semi-closed loop</td> </tr> <tr> <td style="text-align: center;">1</td> <td></td> <td></td> <td></td> </tr> <tr> <td style="text-align: center;">2</td> <td></td> <td></td> <td></td> </tr> <tr> <td style="text-align: center;">3</td> <td style="text-align: center;">pyfx</td> <td style="text-align: center;">Normal excitation</td> <td style="text-align: center;">Position loop excitation fixed (strong)</td> </tr> <tr> <td style="text-align: center;">4</td> <td style="text-align: center;">cdir</td> <td style="text-align: center;">Command polarity (+)</td> <td style="text-align: center;">Command polarity (-)</td> </tr> <tr> <td style="text-align: center;">5</td> <td style="text-align: center;">fdir</td> <td style="text-align: center;">Position detector direction (+)</td> <td style="text-align: center;">Position detector direction (-)</td> </tr> <tr> <td style="text-align: center;">6</td> <td></td> <td></td> <td></td> </tr> <tr> <td style="text-align: center;">7</td> <td></td> <td></td> <td></td> </tr> <tr> <td style="text-align: center;">8</td> <td></td> <td></td> <td></td> </tr> <tr> <td style="text-align: center;">9</td> <td></td> <td></td> <td></td> </tr> <tr> <td style="text-align: center;">A</td> <td></td> <td></td> <td></td> </tr> <tr> <td style="text-align: center;">B</td> <td></td> <td></td> <td></td> </tr> <tr> <td style="text-align: center;">C</td> <td></td> <td></td> <td></td> </tr> <tr> <td style="text-align: center;">D</td> <td style="text-align: center;">od8x</td> <td style="text-align: center;">Magnification of excessive error width x 8 times invalid</td> <td style="text-align: center;">Magnification of excessive error width x 8 times valid</td> </tr> <tr> <td style="text-align: center;">E</td> <td style="text-align: center;">ptyp</td> <td style="text-align: center;">Position control switch type: After zero point return</td> <td style="text-align: center;">Position control switch type: After deceleration stop</td> </tr> <tr> <td style="text-align: center;">F</td> <td style="text-align: center;">zrtn</td> <td style="text-align: center;">Zero point return direction: CCW</td> <td style="text-align: center;">Zero point return direction: CW</td> </tr> </tbody> </table>	F	E	D	C	B	A	9	8	zrtn	ptyp	od8x						7	6	5	4	3	2	1	0			fdir	cdir	pyfx			fclx	bit	Name	Meaning when set to 0	Meaning when set to 1	0	fclx	Closed loop	Semi-closed loop	1				2				3	pyfx	Normal excitation	Position loop excitation fixed (strong)	4	cdir	Command polarity (+)	Command polarity (-)	5	fdir	Position detector direction (+)	Position detector direction (-)	6				7				8				9				A				B				C				D	od8x	Magnification of excessive error width x 8 times invalid	Magnification of excessive error width x 8 times valid	E	ptyp	Position control switch type: After zero point return	Position control switch type: After deceleration stop	F	zrtn	Zero point return direction: CCW	Zero point return direction: CW	0000 to FFFF HEX setting	0000
F	E	D	C	B	A	9	8																																																																																																		
zrtn	ptyp	od8x																																																																																																							
7	6	5	4	3	2	1	0																																																																																																		
		fdir	cdir	pyfx			fclx																																																																																																		
bit	Name	Meaning when set to 0	Meaning when set to 1																																																																																																						
0	fclx	Closed loop	Semi-closed loop																																																																																																						
1																																																																																																									
2																																																																																																									
3	pyfx	Normal excitation	Position loop excitation fixed (strong)																																																																																																						
4	cdir	Command polarity (+)	Command polarity (-)																																																																																																						
5	fdir	Position detector direction (+)	Position detector direction (-)																																																																																																						
6																																																																																																									
7																																																																																																									
8																																																																																																									
9																																																																																																									
A																																																																																																									
B																																																																																																									
C																																																																																																									
D	od8x	Magnification of excessive error width x 8 times invalid	Magnification of excessive error width x 8 times valid																																																																																																						
E	ptyp	Position control switch type: After zero point return	Position control switch type: After deceleration stop																																																																																																						
F	zrtn	Zero point return direction: CCW	Zero point return direction: CW																																																																																																						

(Continued on the next page.)

**4.8 Spindle Parameters**  
**4.8.2 Spindle Parameters**

#	Item	Details	Setting range (unit)	Standard setting																																																																																																				
		<p><b>For others</b> (Continued from the previous page.)</p> <p>Set the synchronous tapping specifications in bit units.</p> <table style="width: 100%; border-collapse: collapse; text-align: center;"> <tr> <td style="border: 1px solid black;">F</td> <td style="border: 1px solid black;">E</td> <td style="border: 1px solid black;">D</td> <td style="border: 1px solid black;">C</td> <td style="border: 1px solid black;">B</td> <td style="border: 1px solid black;">A</td> <td style="border: 1px solid black;">9</td> <td style="border: 1px solid black;">8</td> </tr> <tr> <td style="border: 1px solid black;">zrtn</td> <td style="border: 1px solid black;">ptyp</td> <td style="border: 1px solid black;">od8x</td> <td style="border: 1px solid black;"></td> <td style="border: 1px solid black;"></td> <td style="border: 1px solid black;"></td> <td style="border: 1px solid black;"></td> <td style="border: 1px solid black;">phos</td> </tr> </table> <table style="width: 100%; border-collapse: collapse; text-align: center;"> <tr> <td style="border: 1px solid black;">7</td> <td style="border: 1px solid black;">6</td> <td style="border: 1px solid black;">5</td> <td style="border: 1px solid black;">4</td> <td style="border: 1px solid black;">3</td> <td style="border: 1px solid black;">2</td> <td style="border: 1px solid black;">1</td> <td style="border: 1px solid black;">0</td> </tr> <tr> <td style="border: 1px solid black;"></td> <td style="border: 1px solid black;"></td> <td style="border: 1px solid black;">fdir</td> <td style="border: 1px solid black;">cdir</td> <td style="border: 1px solid black;">pyfx</td> <td style="border: 1px solid black;"></td> <td style="border: 1px solid black;">adin</td> <td style="border: 1px solid black;">fclx</td> </tr> </table> <p><b>(Note)</b> Always set "0" for the empty bits.</p> <table border="1" style="width: 100%; border-collapse: collapse; text-align: center;"> <thead> <tr> <th style="text-align: left;">bit</th> <th style="text-align: left;">Name</th> <th style="text-align: left;">Meaning when set to 0</th> <th style="text-align: left;">Meaning when set to 1</th> </tr> </thead> <tbody> <tr> <td>0</td> <td>fclx</td> <td>Closed loop</td> <td>Semi-closed loop (Gear 1 : 1 only)</td> </tr> <tr> <td>1</td> <td>adin</td> <td>Interpolation A/D compensation invalid</td> <td>Interpolation A/D compensation valid</td> </tr> <tr> <td>2</td> <td></td> <td></td> <td></td> </tr> <tr> <td>3</td> <td>pyfx</td> <td>Normal excitation</td> <td>Position loop excitation fixed (strong)</td> </tr> <tr> <td>4</td> <td>cdir</td> <td>Command polarity (+)</td> <td>Command polarity (-)</td> </tr> <tr> <td>5</td> <td>fdir</td> <td>Position detector direction (+)</td> <td>Position detector direction (-)</td> </tr> <tr> <td>6</td> <td></td> <td></td> <td></td> </tr> <tr> <td>7</td> <td></td> <td></td> <td></td> </tr> <tr> <td>8</td> <td>phos</td> <td>Normal (no compensation)</td> <td>Synchronous tap position compensation valid</td> </tr> <tr> <td>9</td> <td></td> <td></td> <td></td> </tr> <tr> <td>A</td> <td></td> <td></td> <td></td> </tr> <tr> <td>B</td> <td></td> <td></td> <td></td> </tr> <tr> <td>C</td> <td></td> <td></td> <td></td> </tr> <tr> <td>D</td> <td>od8x</td> <td>Magnification of excessive error width × 8 times invalid</td> <td>Magnification of excessive error width × 8 times valid</td> </tr> <tr> <td>E</td> <td>ptyp</td> <td>Position control switch type: After zero point return</td> <td>Position control switch type: After deceleration stop</td> </tr> <tr> <td>F</td> <td>zrtn</td> <td>Zero point return direction: CCW</td> <td>Zero point return direction: CW</td> </tr> </tbody> </table>	F	E	D	C	B	A	9	8	zrtn	ptyp	od8x					phos	7	6	5	4	3	2	1	0			fdir	cdir	pyfx		adin	fclx	bit	Name	Meaning when set to 0	Meaning when set to 1	0	fclx	Closed loop	Semi-closed loop (Gear 1 : 1 only)	1	adin	Interpolation A/D compensation invalid	Interpolation A/D compensation valid	2				3	pyfx	Normal excitation	Position loop excitation fixed (strong)	4	cdir	Command polarity (+)	Command polarity (-)	5	fdir	Position detector direction (+)	Position detector direction (-)	6				7				8	phos	Normal (no compensation)	Synchronous tap position compensation valid	9				A				B				C				D	od8x	Magnification of excessive error width × 8 times invalid	Magnification of excessive error width × 8 times valid	E	ptyp	Position control switch type: After zero point return	Position control switch type: After deceleration stop	F	zrtn	Zero point return direction: CCW	Zero point return direction: CW		
F	E	D	C	B	A	9	8																																																																																																	
zrtn	ptyp	od8x					phos																																																																																																	
7	6	5	4	3	2	1	0																																																																																																	
		fdir	cdir	pyfx		adin	fclx																																																																																																	
bit	Name	Meaning when set to 0	Meaning when set to 1																																																																																																					
0	fclx	Closed loop	Semi-closed loop (Gear 1 : 1 only)																																																																																																					
1	adin	Interpolation A/D compensation invalid	Interpolation A/D compensation valid																																																																																																					
2																																																																																																								
3	pyfx	Normal excitation	Position loop excitation fixed (strong)																																																																																																					
4	cdir	Command polarity (+)	Command polarity (-)																																																																																																					
5	fdir	Position detector direction (+)	Position detector direction (-)																																																																																																					
6																																																																																																								
7																																																																																																								
8	phos	Normal (no compensation)	Synchronous tap position compensation valid																																																																																																					
9																																																																																																								
A																																																																																																								
B																																																																																																								
C																																																																																																								
D	od8x	Magnification of excessive error width × 8 times invalid	Magnification of excessive error width × 8 times valid																																																																																																					
E	ptyp	Position control switch type: After zero point return	Position control switch type: After deceleration stop																																																																																																					
F	zrtn	Zero point return direction: CCW	Zero point return direction: CW																																																																																																					
3394	SP194	VGTP*	Synchronous tapping speed loop gain proportional term	Set the speed loop proportional gain in synchronous tapping mode.	0 to 1000 (1/s)	63																																																																																																		
3395	SP195	VGTI*	Synchronous tapping speed loop gain integral term	Set the speed loop integral gain in synchronous tapping mode.	0 to 1000 (0.1 1/s)	60																																																																																																		
3396	SP196	VGTD*	Synchronous tapping speed loop gain delay advance term	Set the speed loop delay advance gain in synchronous tapping mode. When this parameter is set to "0", PI control is exercised.	0 to 1000 (0.1 1/s)	15																																																																																																		
3397	SP197			Not used. Set to "0".	0	0																																																																																																		

## 4.8 Spindle Parameters

### 4.8.2 Spindle Parameters

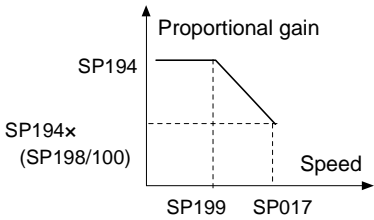
#	Item		Details	Setting range (unit)	Standard setting	
3398	SP198	VCGT*	Target value of variable speed loop proportional gain at synchronous tapping	Set the magnification of speed loop proportional gain with respect to SP194 (VGTP) at the maximum motor speed defined in SP017 (TSP) at synchronous tapping.	0 to 100 (%)	100
3399	SP199	VCST*	Change starting speed of variable speed loop proportional gain at synchronous tapping	Set the speed for starting change of speed loop proportional gain at synchronous tapping.  	0 to 32767 (r/min)	0
3400	SP200	FFC1*	Synchronous tapping acceleration feed-forward gain (gear 1)	Set the acceleration feed-forward gain for selection of gear 000 at synchronous tapping. This parameter should be used when an error of relative position to Z-axis servo is large.	0 to 1000 (%)	0
3401	SP201	FFC2*	Synchronous tapping acceleration feed-forward gain (gear 2)	Set the acceleration feed-forward gain for selection of gear 001 at synchronous tapping.	0 to 1000 (%)	0
3402	SP202	FFC3*	Synchronous tapping acceleration feed-forward gain (gear 3)	Set the acceleration feed-forward gain for selection of gear 010 at synchronous tapping.	0 to 1000 (%)	0
3403	SP203	FFC4*	Synchronous tapping acceleration feed-forward gain (gear 4)	Set the acceleration feed-forward gain for selection of gear 011 at synchronous tapping.	0 to 1000 (%)	0
3404 to 3413	SP204 to SP213			Not used. Set to "0".	0	0
3414	SP214	TZRN	Synchronous tapping zero point return speed	This parameter is valid when SP193 (SPECT) bitE is set to "0". Set the zero point return speed used when the speed loop changes to the position loop.	0 to 500 (r/min)	50
3415	SP215	TPDT	Synchronous tapping zero point return deceleration rate	This parameter is valid when SP193 (SPECT) bitE is set to "0". Set the deceleration rate where the machine starts to decelerate when it returns to the target stop point during synchronous tapping zero point return. When the machine tends to overshoot at the stop point set a smaller value.	1 to 10000 (pulse)	



## 4.8 Spindle Parameters

### 4.8.2 Spindle Parameters

#	Item		Details	Setting range (unit)	Standard setting	
3416	SP216	TPST	Synchronous tapping zero point return shift amount	This parameter is valid when SP193 (SPECT) bitE is set to "0". Set the synchronous tapping zero point position.	0 to 4095	
3417	SP217	TINP	Synchronous tapping in-position width	Set the position error range in which in-position signal is output during synchronize tapping.	1 to 2880 (1/16°)	
3418	SP218	TODR	Excessive error width at synchronous tapping	Set the excessive error width at synchronous tapping.	1 to 32767 (pulse) (1 pulse = 0.088°)	
3419	SP219	IQGT*	Current loop gain magnification 1 at synchronous tapping	Set the magnification of current loop gain (torque component) during synchronous tapping.	1 to 1000 (%)	
3420	SP220	IDGT*	Current loop gain magnification 2 at synchronous tapping	Set the magnification of current loop gain (excitation component) during synchronous tapping.	1 to 1000 (%)	
3421	SP221	PG2T	Position loop gain 2 at synchronous tapping	Set the second position loop gain when high-gain control is exercised during synchronous tapping. When this parameter is not used, set to "0".	0 to 999 (1/s)	
3422	SP222	PG3T	Position loop gain 3 at synchronous tapping	Set the third position loop gain when high-gain control is exercised during synchronous tapping. When this parameter is not used, set to "0".	0 to 999 (1/s)	
3423 to 3424	SP223 to SP224			Not used. Set to "0".	0	
3425	SP225	OXKPH	Fixed control constant	Set by Mitsubishi. Set "0" unless designated in particular.	0	0
3426	SP226	OXKPL				
3427	SP227	OXVKP				
3428	SP228	OXVKI				
3429	SP229	OXSFT				
3430	SP230					
3431	SP231					
3432	SP232					
3433	SP233	JL*	Disturbance observer general inertia scale	Set the ratio of the motor inertia + load inertia and motor inertia.  Setting value = $\frac{\text{Motor inertia} + \text{load inertia}}{\text{Motor inertia}} \times 100$  (Normally, set "100" or more. When less than "50" is set, the setting will be invalid.)	0 to 5000 (%)	0
3434	SP234	OBS1*	Disturbance observer low path filter frequency	Set the frequency of the low path filter for when the distance observer is valid.  Setting (1/s) = $2\pi f$  f: Approx. 1.5 times the disturbance frequency	0 to 1000 (1/s)	0

## 4.8 Spindle Parameters

### 4.8.2 Spindle Parameters

#	Item			Details	Setting range (unit)	Standard setting
3435	SP235	OBS2*	Disturbance observer gain	Set the gain for the disturbance observer.	0 to 500 (%)	0
3436 to 3452	SP236 to SP252			Not used. Set to "0".	0	0
3453	SP253	DA1NO	D/A output channel-1 data number	Set the output data number for channel 1 of the D/A output function. When the setting value is "0", the output is speedometer. Refer to "4.8.3 Supplementary Explanation".	-32768 to 32767	0
3454	SP254	DA2NO	D/A output channel-2 data number	Set the output data number for channel 2 of the D/A output function. When the setting value is "0", the output is load meter. Refer to "4.8.3 Supplementary Explanation".	-32768 to 32767	0
3455	SP255	DA1MPY	DA output channel 1 magnification	Set the data magnification for channel 1 of the D/A output function. The output magnification is (setting value)/256. When set to "0", the output magnification becomes 1-fold, in the same manner as when "256" is set. Refer to "4.8.3 Supplementary Explanation".	-32768 to 32767 (1/256-fold)	0
3456	SP256	DA2MPY	DA output channel 2 magnification	Set the data magnification for channel 2 of the D/A output function. The output magnification is (setting value)/256. When set to "0", the output magnification becomes 1-fold, in the same manner as when "256" is set. Refer to "4.8.3 Supplementary Explanation".	-32768 to 32767 (1/256-fold)	0
3457 to 3520	SP257 to SP320	RPM* BSD*	Motor constant (H coil)	This parameter is valid only in the following two conditional cases:  (a) In case that SP034 (SFNC2) bit0=1 and SP034 (SFNC2) bit2=0 Set the motor constants when using a special motor, not described in the SP040 (MTYP) explanation and when not using the coil changeover motor.  (b) In case that SP034 (SFNC2) bit0=1 and SP034 (SFNC2) bit2=1 Set the motor constant of the H coil of the coil changeover motor.  <b>(Note)</b> It is not allowed for the user to change the setting.	0000 to FFFF HEX setting	0000
3521 to 3584	SP321 to SP384	RPML* BSDL*	Motor constant (L coil)	This parameter is valid only in the following conditional case:  (a) In case that SP034 (SFNC2) bit0=1 and SP034 (SFNC2) bit2=1 Set the motor constant of the L coil of the coil changeover motor.  <b>(Note)</b> It is not allowed for the user to change the setting.	0000 to FFFF HEX setting	0000

## 4.8 Spindle Parameters

### 4.8.3 Supplementary Explanation

#### 4.8.3 Supplementary Explanation (for D/A output functions)

##### (1) Outline

The D/A output function is mounted in the standard system in the MDS-A-SP/MDS-B-SP. Using this D/A output function, the drive unit status and each data can be confirmed.

##### (2) Hardware specifications

- 2 channels
- 8 bit      0 to +10V
- Output pin            CH 1: CN9-9 pin  
                              CH 2: CN9-19 pin  
                              GND: CN9-1.11 pin

##### (3) Parameters

Set the data No. and output magnification of each channel according to the parameters below.

Name	Details
SP253	D/A channel 1 data No.
SP254	D/A channel 2 data No.
SP255	D/A channel 1 output magnification
SP256	D/A channel 2 output magnification

##### (4) Output data No.

Set the No. of the data to be output in SP253 and SP254. A correlation of the output data and the data No. is shown below.

No. (setting value)	CH1		CH2	
	Output data	Units	Output data	Units
0	Speedometer output	Maximum speed at 10V	Load meter output	120% load at 10V
2	Current command	When the actual data is 4096, the current command data is regarded as 100%.	Same as CH1	
3	Current feedback	When the actual data is 4096, the current feedback data is regarded as 100%.		
4	Speed feedback	Actual data    r/min		
6	Position droop low-order	Interpolation units		
7	Position droop high-order	when the actual data is 23040000, the position droop data is regarded as 360°.		
8	Position FΔT low-order	Interpolation units/NC communication cycle		
9	Position FΔT high-order			
10	Position command low-order	Interpolation units		
11	Position command high-order	when the actual data is 23040000, the position command data is regarded as 360°.		
12	Feedback position low-order	Interpolation units		
13	Feedback position high-order	when the actual data is 23040000, the feedback position data is regarded as 360°.		
80	Control input 1	Bit correspondence		
81	Control input 2			
82	Control input 3			
83	Control input 4			
84	Control output 1	Bit correspondence		
85	Control output 2			
86	Control output 3			
87	Control output 4			

**(Note)** The % of the current command and current feedback indicate 30min. rating = 100%.

**4.8 Spindle Parameters**  
**4.8.3 Supplementary Explanation**

---

**(5) Setting the output magnification**

Set the output magnification in SP255 and SP256.

$\text{Data} = \text{actual data} \times \frac{\text{SP255 or SP256}}{256}$
---

Using the expression above,

- 1) Output data other than speedometer output and load meter output carries out the D/A output in Fig. 1 below.
- 2) Speedometer data and load meter data carries out the D/A output in Fig. 2 below.

**D/A output voltage**

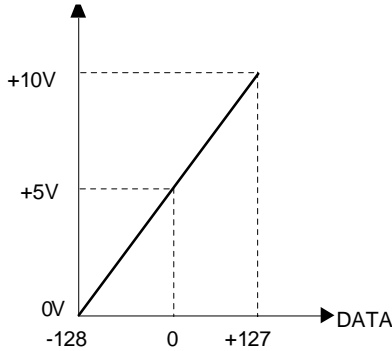

**Fig. 1**

**D/A output voltage**

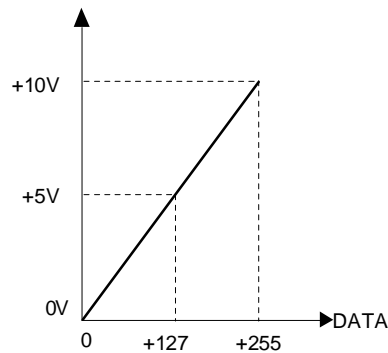

**Fig. 2**

**(Example 1)** Current command, current feedback

Data units are 100% converted when the actual data = 4096.

Therefore, for example, the actual data is output as shown below during +120% current feedback.

$$\text{Actual data} = 4096 \times 1.2 = 4915$$

If "256" is set (magnification 1) in parameter SP255 (SP256), the D/A output voltage from Fig. 1 will be as shown below, exceeding the D/A output voltage maximum value.

$$5V + \{4915 \times 1 \times (5V/128)\} = 197V > 10V$$

Therefore, if (for example) "6" is set in parameter SP255 (SP256), the D/A output voltage will become as shown below, and data confirmation will be possible.

$$5V + \{4915 \times 6/256 \times (5V/128)\} = 9.5V < 10V$$

## 4.8 Spindle Parameters

### 4.8.3 Supplementary Explanation

---

**(Example 2)** Speed feedback

Data units are r/min.

Consequently, at (for example) +2000r/min, the motor speed will be output at "2000".

If "256" is set (magnification 1) in parameter SP255 (SP256), the D/A output voltage from Fig. 1 will be as shown below, exceeding the D/A output voltage maximum value.

$$5V + \{2000 \times 1 \times (5V/128)\} = 83.125V > 10V$$

Therefore, if (for example) "16" is set in parameter SP255 (SP256), the D/A output voltage will become as shown below, and data confirmation will be possible.

$$5V + \{2000 \times 16/256 \times (5V/128)\} = 9.88V < 10V$$

**(Example 3)** Position droop

The data units are r/min. Data units are 100% converted when the actual data = 4096.

Therefore, for example, the actual data is output as shown below during the +0.1-degree position droop.

$$\text{Actual data} = 0.1 \times 23040000/360 = 6400$$

If "256" is set (magnification 1) in parameter SP255 (SP256), the D/A output voltage from Fig. 1 will be as shown below, exceeding the D/A output voltage maximum value.

$$5V + \{6400 \times 1 \times (5V/128)\} = 255V > 10V$$

Therefore, if (for example) "5" was set in parameter SP255 (SP256), the D/A output voltage will become as shown below, and data confirmation will be possible.

$$5V + \{2000 \times 5/256 \times (5V/128)\} = 9.88V < 10V$$

**(Example 4)** Confirm the orientation complete signal (ORCF) in the control output 4L.

The data units are bit corresponding data.

Refer to the instruction manual for the meanings of the control output 4L bit corresponding signals.

The orientation complete signal (ORCF) corresponds to the control output 4L/bit 4.

Therefore, for example, the actual data is output as shown below when ORCF= ON.

$$\text{bit 4 corresponding actual data} = 2^4 = 16$$

If "256" is set (magnification 1) in parameter SP255 (SP256), the D/A output voltage from Fig. 1 will be as shown below, and data confirmation will be possible.

$$5V + \{16 \times 1 \times (5V/128)\} = 5.625V < 10V$$

Note that, if a bit other than bit4 is ON, the current of that bit will be added to the 5.625V shown above, and at the actual ORCF signal measurement will be as shown below, so confirm the changed voltage.

$$(5.625V - 5V) = 0.625V$$

## 4.8 Spindle Parameters

### 4.8.4 Spindle-Type Servo Parameters

#### 4.8.4 Spindle-Type Servo Parameters

There is a total of 64 spindle-type servo parameters, which can be changed from any screen.

Set the SV001 to SV064 spindle-type servo parameters not described in this section in the same manner as the normal NC control axis. (Refer to section "4.7 Servo parameters".)

(Note) In the bit explanation below, set all bits not used, including empty bits to "0".

After setting parameters indicated with "\*" in the table, turn Off the NC power. The parameter will be validated after the power is turned ON again.

#	Item			Details	Setting range (unit)
3601	SV001	PC1*	Motor gear ratio	Set the number of motor gears and machine gears. Set the spindle and motor rotation ratio with PC1 and PC2 so that the following is established: PC1/PC2 = spindle rotation speed/motor rotation speed <b>(Example)</b> When motor is 3000r/min, and spindle is 1000r/min: 1000/3000 = 1/3 Thus, set PC1 to 1 and PC2 to 3.	1 to 30
3602	SV002	PC2*	Machine gear ratio		
3603	SV003	PGN1	Position loop gain 1	Set the position loop gain.	1 to 200 (1/s)
3604	SV004	PGN2	Position loop gain 2	When using SHG control, set this parameter with SV057 (SHGC).	0 to 999 (1/s)
3618	SV018	PIT*	Ball screw pitch	Set the ball screw pitch. Set "360" for a rotation axis. When using spindle-type servomotor control, always set "360". To set the spindle's maximum rotation speed to 5000r/min or more, set this to "180".	1 to 32767 (mm)
3649	SV049	PGN1sp	C axis synchronous tap position loop gain 1	Set the position loop gain to change when using the Spindle/C axis control's C axis or when using synchronous tap. Whether to change over or not is selected with the base common parameter 1370 sp_7/bit2, bit 3.	0 to 200 (1/s)
3650	SV050	PGN2sp	C axis synchronous tap position loop gain	Set this with SV058 to use high-gain control when changing the position loop gain while using the spindle/C axis control's C axis or while using synchronous tap. Whether to change over or not is selected with the base common parameter 1370 sp_7/bit2, bit 3.	0 to 999 (1/s)
3657	SV057	SHGC	High-gain control constant	Set this to use SHG control. Set to "0" when not using this function.	0 to 999 (1/s)
3658	SV058	SHGCsp	C axis synchronous tap high-gain constant	Set this to use SHG control during spindle synchronization control. Set to "0" when not using this function.	0 to 999 (1/s)

**(Note 1)** When SV018 is set to "180", the command rotation speed can be doubled compared to when "360" is set. However, as the command unit will be doubled, the accuracy for indexing, etc., could be affected.

**(Note 2)** When SV018 is changed from "360" to "180", the parameters related to the unit must all be reviewed.

### CAUTION

 If SV018 is not set to "360" or "180", the function will not activate correctly. Always set this parameter to "360" or "180".

## 4.9 PLC Constants

### 4.9.1 PLC Constants

---

## 4.9 PLC Constants

### 4.9.1 PLC Constants

The parameters used in the user PLC can be set on this screen.  
Refer to the explanation manual published by the machine maker for parameter details.

#	Item	Details	Display range
6301 to 6348	PLC constant	There are PLC constants set by data type in the parameters that can be used in the user PLC. The set data is set and backed-up by the PLC R register. Conversely, when data is set in the R register corresponding to the constant with the sequence program MOV command, etc., it is backed up. Note that the display will not change, so temporarily change to another screen, and then select the screen again. The No. of constants is 48, and the setting range is $\pm 8$ digits.	-99999999 to 99999999

## 4.9 PLC Constants

### 4.9.2 PLC Timer

---

#### 4.9.2 PLC Timer

The timer setting values used by the user PLC can be set on this screen.

#	Item	Details	Display range
6500 to 6515	[10ms] adding timer	This timer has a minimum input increment of 0.01s. When the conditions for input are satisfied, it starts counting. When the count reaches setting value, the contact point becomes ON.  Count is reset to 0 if the conditions for input are aborted. 16 points (T0 to T15)	0 to 32767
6556 to 6635	[100ms] adding timer	This timer has a minimum input increment of 0.1s. Its functions are the same as those for 10ms timer. 80 points (T56 to T135)	0 to 32767
6732 to 6739	[100ms INC.] cumulative timer	This timer has a minimum input increment of 0.1s. Once conditions for input are satisfied, it starts counting. When it reaches setting value, its contact goes ON.  Even if conditions for input are aborted, current value (count value) is held and contact status does not change. Count value is reset to 0 by RST command and contact goes OFF. 8 points (T232 to T239)	0 to 32767



## 4.10 Custom Variables

---

### 4.9.3 PLC Counter

The counter setting value used by the user PLC can be set on this screen.

#	Item	Details	Display range
6200 to 6223	Counter	It detects rising of conditions for input and counts with incremental system. Count value is not cleared even if input conditions are aborted. Count value is reset to 0 by RST command. 24 points (C0 to C23)	0 to 32767

### 4.9.4 Selecting the PLC Bit

The bit parameter used in the user PLC can be set on this screen.

#	Item	Details	Display range
6401 to 6496	Bit selection	There are bit selection parameters set by bit type in the parameters that can be used in the user PLC. The set data is set and backed-up by the PLC R register. When bit operation is used in the sequence program, it is used after temporarily transferring the R register details to the memory (M) with a MOV command. Conversely, when data is set in the R register corresponding to the bit selection with the MOV command, etc., it is backed up.	0: OFF 1: ON

**(Note)** Bit selection parameters #6449 to #6496 are used by the machine maker and Mitsubishi, so the details are fixed.

## 4.10 Custom Variables

The custom variable data can be set on this screen.

#	Item	Details
801 to 999	Custom variables	These indicate the variable numbers and their contents. When the variable data is "empty", the data display area will be blank. Data with a large number of digits will be exponentially displayed.

## 4.11 Macro List

### 4.11 Macro List

Designate when calling the user macro program and subprogram call with a specific code (G, M, S, T, second miscellaneous code).

#	Item	Details	Setting range (unit)										
7201 to 7291	G [01] to G [10]	<b>&lt;Code&gt;</b> Set up to 10 random G codes from G [01] to G [10] when calling the user macro program with the G command. (Note that the G code used in the system cannot be set.)	1 to 255										
		<b>&lt;Type&gt;</b> <table border="1" style="margin-left: 20px;"> <tr> <td style="text-align: center;">0</td> <td>M98 P####; and equivalent value call</td> </tr> <tr> <td style="text-align: center;">1</td> <td>G65 P####; and equivalent value call</td> </tr> <tr> <td style="text-align: center;">2</td> <td>G66 P####; and equivalent value call</td> </tr> <tr> <td style="text-align: center;">3</td> <td>G66.1 P####; and equivalent value call</td> </tr> <tr> <td style="text-align: center;">Other</td> <td>M98 P####; and equivalent value call</td> </tr> </table>	0	M98 P####; and equivalent value call	1	G65 P####; and equivalent value call	2	G66 P####; and equivalent value call	3	G66.1 P####; and equivalent value call	Other	M98 P####; and equivalent value call	0 to 3
		0	M98 P####; and equivalent value call										
1	G65 P####; and equivalent value call												
2	G66 P####; and equivalent value call												
3	G66.1 P####; and equivalent value call												
Other	M98 P####; and equivalent value call												
<b>&lt;Program No.&gt;</b> Set the user macro program No. to be called.	1 to 99999999												
7401 to 7471	G200 G900	<b>&lt;Type&gt;</b> Same as the G call macro.	0 to 3										
		<b>&lt;Program No.&gt;</b> Set the 100th place value of the user macro program No. to be called.	0 to 9										
7481	Pcint	<b>&lt;Program No.&gt;</b> Set the 100th place value of the PC interrupt program. <b>(Note)</b> Set to "0" when there is no interrupt.	0 to 9										

## 4.11 Macro List

#	Item	Details	Setting range (unit)														
7001 to 7091	M [01] to M [10]	<p><b>&lt;Code&gt;</b></p> <p>Set up to 40 random M codes from M[01] to M[40] when calling the user macro program (subsystem program) with the M command.</p> <p>(Note that M96 to M99 and the M codes used in the system cannot be set.)</p>	1 to 9999														
10001 to 10091	M [11] to M [20]	<p><b>&lt;Type&gt;</b></p> <table border="1" style="width: 100%; border-collapse: collapse;"> <tr> <td style="text-align: center;">0</td> <td>M98 P△△△△; and equivalent value call</td> </tr> <tr> <td style="text-align: center;">1</td> <td>G65 P△△△△; and equivalent value call</td> </tr> <tr> <td style="text-align: center;">2</td> <td>G66 P△△△△; and equivalent value call</td> </tr> <tr> <td style="text-align: center;">3</td> <td>G66.1 P△△△△; and equivalent value call</td> </tr> <tr> <td style="text-align: center;">4</td> <td>G144A P△△△△D0; and equivalent value call</td> </tr> <tr> <td style="text-align: center;">5</td> <td>G144A P△△△△D1; and equivalent value call</td> </tr> <tr> <td style="text-align: center;">Other</td> <td>M98 P△△△△; and equivalent value call</td> </tr> </table>	0	M98 P△△△△; and equivalent value call	1	G65 P△△△△; and equivalent value call	2	G66 P△△△△; and equivalent value call	3	G66.1 P△△△△; and equivalent value call	4	G144A P△△△△D0; and equivalent value call	5	G144A P△△△△D1; and equivalent value call	Other	M98 P△△△△; and equivalent value call	0 to 5
0	M98 P△△△△; and equivalent value call																
1	G65 P△△△△; and equivalent value call																
2	G66 P△△△△; and equivalent value call																
3	G66.1 P△△△△; and equivalent value call																
4	G144A P△△△△D0; and equivalent value call																
5	G144A P△△△△D1; and equivalent value call																
Other	M98 P△△△△; and equivalent value call																
10101 to 10191	M [21] to M [30]	<p><b>&lt;Program No.&gt;</b></p> <p>Set the user macro program (subsystem program) No. to be called.</p>	1 to 99999999														
10201 to 10291	M [31] to M [40]	<p><b>(Note 1)</b> The macro program will be called by the M code set in this screen when the basic common parameter M call macro (Mmac) is valid.</p> <p><b>(Note 2)</b> The M command code value is used as the subsystem identification No. for a subsystem call (type = 4 or 5).</p>															
7102	M2mac	<p>Set when calling the user macro program with the second miscellaneous function command (the address set in the basic system parameter M2name).</p> <p><b>(Note)</b> The macro program set on this screen will be called when the second miscellaneous code call macro (M2mac) of the basic specification parameter is valid.</p>															
		<p><b>&lt;Type&gt;</b></p> <p>Same as the G call macro.</p>	0 to 3														
		<p><b>&lt;Program No.&gt;</b></p> <p>Same as the G call macro.</p>	1 to 99999999														
7302	Smac	<p>Set when calling the user macro program with an S command.</p> <p><b>(Note)</b> The macro program set on this screen will be called when the basic specification parameter S call macro (Smac) is valid.</p>	0 to 3														
		<p><b>&lt;Type&gt;</b></p> <p>Same as the G call macro.</p>	0 to 3														
		<p><b>&lt;Program No.&gt;</b></p> <p>Same as the G call macro.</p>	1 to 99999999														

## 4.11 Macro List

#	Item	Details	Display range (unit)																											
7312	Tmac	<p>Set when calling a user macro program with a T command.</p> <p><b>(Note)</b> The macro program set on this screen will be called when the basic specification parameter T call macro (Tmac) is valid.</p>																												
		<p><b>&lt;Type&gt;</b></p> <table border="1" style="width: 100%; border-collapse: collapse; margin-bottom: 10px;"> <tbody> <tr> <td style="width: 5%; text-align: center;">0</td> <td style="width: 55%;">M98P_ ; and equivalent value call</td> <td style="width: 40%;">Macro call is carried out regardless of the No. of T digits</td> </tr> <tr> <td style="text-align: center;">1</td> <td>G65P_ ; and equivalent value call</td> <td></td> </tr> <tr> <td style="text-align: center;">2</td> <td>G66P_ ; and equivalent value call</td> <td></td> </tr> <tr> <td style="text-align: center;">3</td> <td>G66.1P_ ; and equivalent value call</td> <td></td> </tr> <tr> <td style="text-align: center;">4</td> <td>M98P_ ; and equivalent value call</td> <td>Macro call is not carried out for T1 digits, or T2 digits.</td> </tr> <tr> <td style="text-align: center;">5</td> <td>G65P_ ; and equivalent value call</td> <td>(Valid only for T3 and T4 digits)</td> </tr> <tr> <td style="text-align: center;">6</td> <td>G66P_ ; and equivalent value call</td> <td></td> </tr> <tr> <td></td> <td>G66.1P_ ; and equivalent value call</td> <td></td> </tr> <tr> <td style="text-align: center;">Other</td> <td>M98P_ ; and equivalent value call</td> <td>Same as type 0</td> </tr> </tbody> </table>	0	M98P_ ; and equivalent value call	Macro call is carried out regardless of the No. of T digits	1	G65P_ ; and equivalent value call		2	G66P_ ; and equivalent value call		3	G66.1P_ ; and equivalent value call		4	M98P_ ; and equivalent value call	Macro call is not carried out for T1 digits, or T2 digits.	5	G65P_ ; and equivalent value call	(Valid only for T3 and T4 digits)	6	G66P_ ; and equivalent value call			G66.1P_ ; and equivalent value call		Other	M98P_ ; and equivalent value call	Same as type 0	0 to 7
0	M98P_ ; and equivalent value call	Macro call is carried out regardless of the No. of T digits																												
1	G65P_ ; and equivalent value call																													
2	G66P_ ; and equivalent value call																													
3	G66.1P_ ; and equivalent value call																													
4	M98P_ ; and equivalent value call	Macro call is not carried out for T1 digits, or T2 digits.																												
5	G65P_ ; and equivalent value call	(Valid only for T3 and T4 digits)																												
6	G66P_ ; and equivalent value call																													
	G66.1P_ ; and equivalent value call																													
Other	M98P_ ; and equivalent value call	Same as type 0																												
		<p><b>&lt;Program No.&gt;</b></p> <p>Set the user macro program No. to be called.</p>	1 to 99999999																											

## 4.12 Position Switch

### (1) Function outline

The position switch (psw) is used as an alternate switch for the dog switch provided on an axis of the machine. The position switch uses parameters by which the names of axes and their corresponding coordinates indicating imaginary dog positions are defined in advance. When the machine reaches the imaginary dog position, a signal is output to the PLC interface. The position switch thus works as an imaginary dog switch.

### (2) Operation

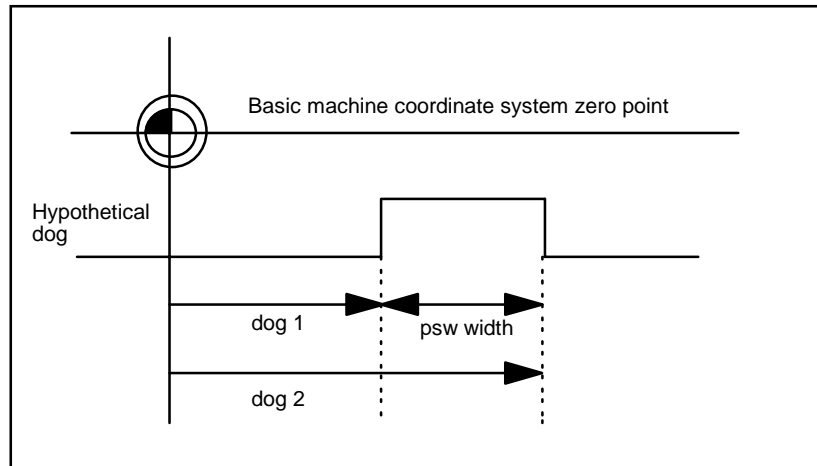





Set the coordinate position of the position switch using the basic machine coordinate system as a reference.

(The basic machine coordinate system is the machine's unique coordinate system using the position set in the parameter as the zero point.)

This function is valid only for the axis that has been returned to the zero point after the power is turned ON.

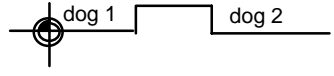
## 4.12 Position Switch

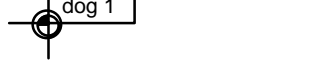
### (3) Example of setting and executing dog1 and dog2

dog1 and dog2 setting	Operation	Explanation
dog1 < dog2		When dog2 is greater than dog1.
dog1 > dog2		When dog1 is greater than dog2.
dog2 > machine end		When dog2 is greater than the machine end.
dog1 = dog2		When dog1 and dog2 is identical, a signal is output at the dog1 position.

### (4) Position switch signal output

Instead of the dog switch provided on the machine axis, the coordinate values indicating imaginary dog positions (dog1 and dog2) on the coordinate axis of the axis name preset with axis are set with the position switches (PSW1 to PSW8). When the machine reaches the position, the signal is output to the device corresponding to the PLC interface.

<For system 1 (\$1)>

#	Item	Details	Setting range (unit)
7501	psw1	Position switch 1	-99999.999 to 99999.999 (0.001mm)
7511	psw2	Position switch 2	
7521	psw3	Position switch 3	
7531	psw4	Position switch 4	
7541	psw5	Position switch 5	
7551	psw6	Position switch 6	
7561	psw7	Position switch 7	
7571	psw8	Position switch 8	

The device that outputs the signal corresponds to each position switch (psw1 to psw8) in each system as shown below.

Position switch	Device outputting signal (\$1: system 1)							
	\$1	\$2	\$3	\$4	\$5	\$6	\$7	\$8
psw1 to psw8	X270 to X277	X5B0 to X5B7	X700 to X707	X780 to X787	X800 to X807	X880 to X887	X900 to X907	X980 to X987

## 4.13 Machine Error Compensation

### 4.13.1 Function Outline

Machine error compensation includes two independent functions: memorized pitch error compensation and memorized relative position compensation.

#### (1) Memorized pitch error compensation

According to the specified parameters, this method compensates an axis feed error caused by a ball screw pitch error, etc.

With the reference point defined as the base, set the compensation amount in the division points obtained by equally dividing the machine coordinates. (See Fig. 1)

The compensation amount can be set by either the absolute or incremental system.

Select the desired method with the #1308:Pinc\*. Machine position is compensated between division points  $n$  and  $n+1$  as much as compensation amount between them by linear approximation.

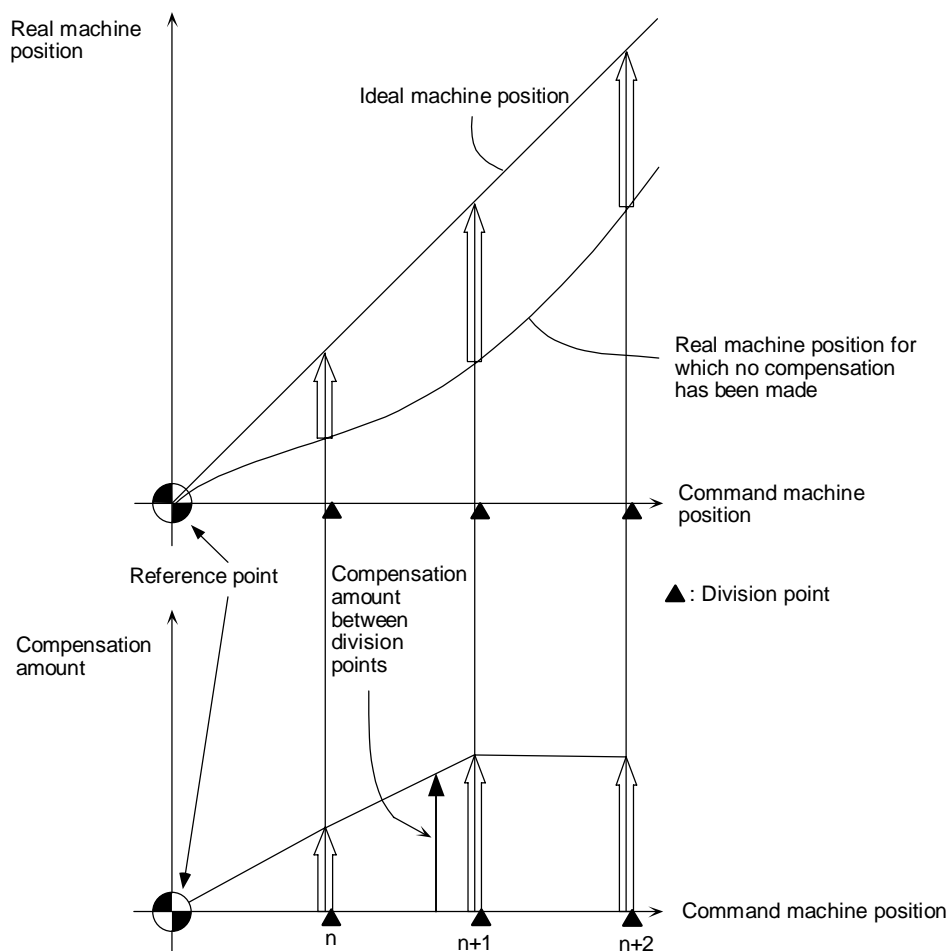

Fig. 1 Relationship between the compensation amount and machine position

## 4.13 Machine Error Compensation

### 4.13.1 Function Outline

#### (2) Memorized relative position compensation

This method, according to the parameters specified in advance, compensates the relative position error between two orthogonal axes caused by deflection of the moving stand.

For this, as shown in Fig. 2, specify the compensation amount in the compensation axis direction in the division points obtained by equally dividing the machine coordinates of the base axis.

The base axis is one of the two orthogonal axes to which relative position compensation applies. This axis is used as the criterion for relative-error measurement. The compensation axis is the coordinate axis that is orthogonal to the base axis. The compensation is actually made for this coordinate axis.

The section between division points  $n$  and  $n+1$  is compensated smoothly by linear approximation.

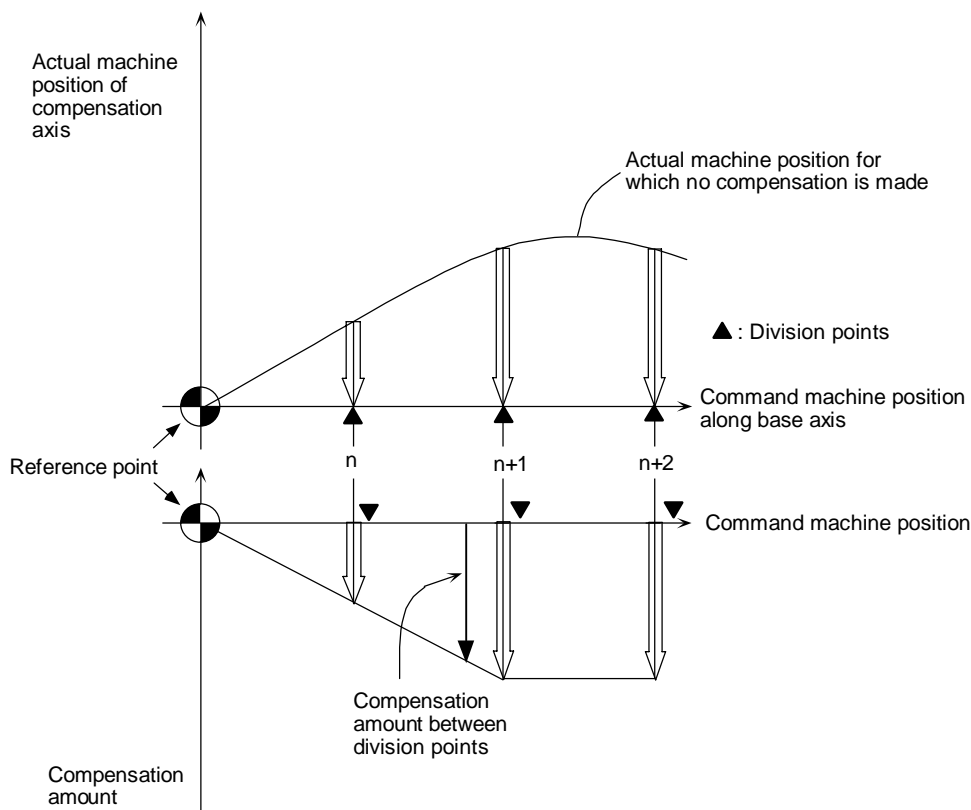

Fig. 2 Relationship between base and compensation axes



**4.13 Machine Error Compensation**  
**4.13.1 Function Outline**

**(Base common parameter)**

#	Item		Details	Setting range
1308	Pinc*	Machine error offset increment method	Specify whether the incremental volume method or absolute volume method is to be used to set machine error offset data.	0: Absolute volume method 1: Incremental volume method

**Machine error compensation <1st axis>**

#	Item		Details	Setting range																		
4001	cmpax	Basic axis	1) For pitch error compensation, set the name of the axis and system No. to be compensated. 2) For relative position compensation, set the name of the axis to be the base axis.	Axis address, such as X, Y, Z, U, V, W, A, B, C and system No.																		
4002	drcax	Compensation axis	1) For pitch error compensation, set the same axis name and system No. as #4001 cmpax. 2) For relative position compensation, set the name of the axis to be actually compensated.	Axis address, such as X, Y, Z, U, V, W, A, B, C and system No.																		
4003	rdvno	Division point number at reference point position	Set the division point compensation No. corresponding to the reference point position of the basic axis. In actual use, this is the reference point and there is no corresponding division point compensation No. Set a number that is decremented by 1.	4301 to 5836																		
4004	mdvno	Division point number at the most negative side	Set the division point compensation No. to the farthest negative side from the basic axis' reference point.																			
4005	pdvno	Division point number at the most positive side	Set the division point compensation number to the farthest positive side from the basic axis' reference point.																			
4006	sc	Compensation scale factor	Set the scale of the compensation amount set in the compensation No. (in compensation amount table). When the compensation scale is set to "1", the compensation amount unit will be the same as the output unit. Compensation amount unit = output unit * compensation scale	0 to 99																		
4007	spcdv	Division interval	Set the interval to divide the basic axis. <table border="1" style="margin-left: 20px;"> <thead> <tr> <th rowspan="2">Input unit</th> <th colspan="2">Linear axis</th> <th rowspan="2">Rotation axis</th> </tr> <tr> <th>Machine constant metric</th> <th>Machine constant inch</th> </tr> </thead> <tbody> <tr> <td>A</td> <td>0.01mm</td> <td>0.001inch</td> <td>0.01°</td> </tr> <tr> <td>B</td> <td>0.001mm</td> <td>0.0001inch</td> <td>0.001°</td> </tr> <tr> <td>C</td> <td>0.0001mm</td> <td>0.00001inch</td> <td>0.0001°</td> </tr> </tbody> </table> <p><b>(Note)</b> If the division interval is set to "0", compensation will not be executed. There is no limit to the minimum value for the division interval, but appropriate data allowing for the machine's stroke, etc., should be set.</p>	Input unit	Linear axis		Rotation axis	Machine constant metric	Machine constant inch	A	0.01mm	0.001inch	0.01°	B	0.001mm	0.0001inch	0.001°	C	0.0001mm	0.00001inch	0.0001°	0 to 9999999
Input unit	Linear axis		Rotation axis																			
	Machine constant metric	Machine constant inch																				
A	0.01mm	0.001inch	0.01°																			
B	0.001mm	0.0001inch	0.001°																			
C	0.0001mm	0.00001inch	0.0001°																			

## 4.13 Machine Error Compensation

### 4.13.2 Setting Compensation Data

#### Machine error data

#	Item	Details	Setting range
4301 • • • 5836		Set the compensation amount for each axis.	-128 to 128 The actual compensation amount will be the value obtained by multiplying the setting value with the compensation scale.

#### 4.13.2 Setting Compensation Data

Compensation data can be set according to either absolute or incremental system.

"1308:Pinc\*"    0: Absolute system  
                    1: Incremental system

##### (1) Absolute system

Feed from the reference point to each division point is executed as shown in Fig. 3. The following is obtained at this time. Set it as the compensation amount.

$$(\text{Specified position} - \text{Real machine position}) \times 2 \text{ (Unit of output)}$$

For example, assume that the feed from the reference point to the +100mm position is executed. Also, assume that the real machine position is 99.990mm. In this case, the following value is defined as the compensation amount used at the +100mm position:

$$(100000 - 99990) \times 2 = 20 \text{ pulses}$$

The resultant value is defined as the compensation amount. Assume that the real machine position resulting when feed to the -100mm position is executed, is -99.990mm. In this case, the following value is defined as the compensation amount used at the -100mm position:

$$(-100000 - (-99990)) \times 2 = -20 \text{ pulses}$$

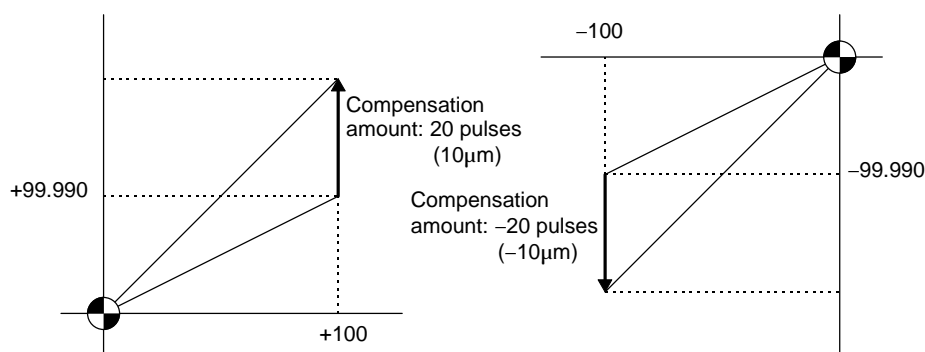

Fig. 3

4.13 Machine Error Compensation  
 4.13.2 Setting Compensation Data

(2) Incremental system

Fig. 4 contains a machine position that is placed in the positive direction with respect to the reference point. Assume that feed from division n-1 to n (division interval) is executed. In this case, the following value is defined as the compensation amount:

$$(\text{Division interval} - \text{Actual movement distance}) \times 2 (\text{Unit of output})$$

Fig. 5 contains a machine position that is placed in the negative direction with respect to the reference point. Assume that feed from division point n+1 to n by the division interval is executed. In this case, the following value is defined as the compensation amount:

$$(\text{Division interval} + \text{Actual movement distance}) \times 2 (\text{Unit of output})$$

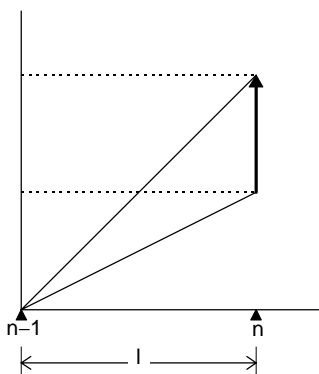

Fig. 4

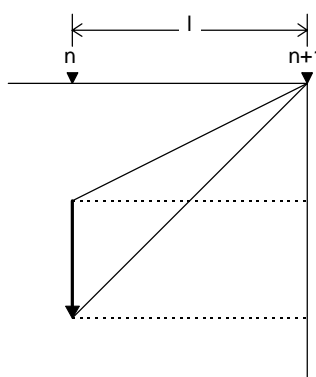

Fig. 5

n: Division point compensation number  
 l: Division interval

Unit : Unit of output  
 Range : -128 to 127

**(Note)** The unit of output is used as the unit of setting. The actual unit of compensation pulses depends on the compensation scale factor.

**4.13 Machine Error Compensation**  
**4.13.3 Example in Using a Linear Axis as the Base Axis**

**4.13.3 Example in Using a Linear Axis as the Base Axis**

**(1) When the range compensated is on both sides of the reference point**

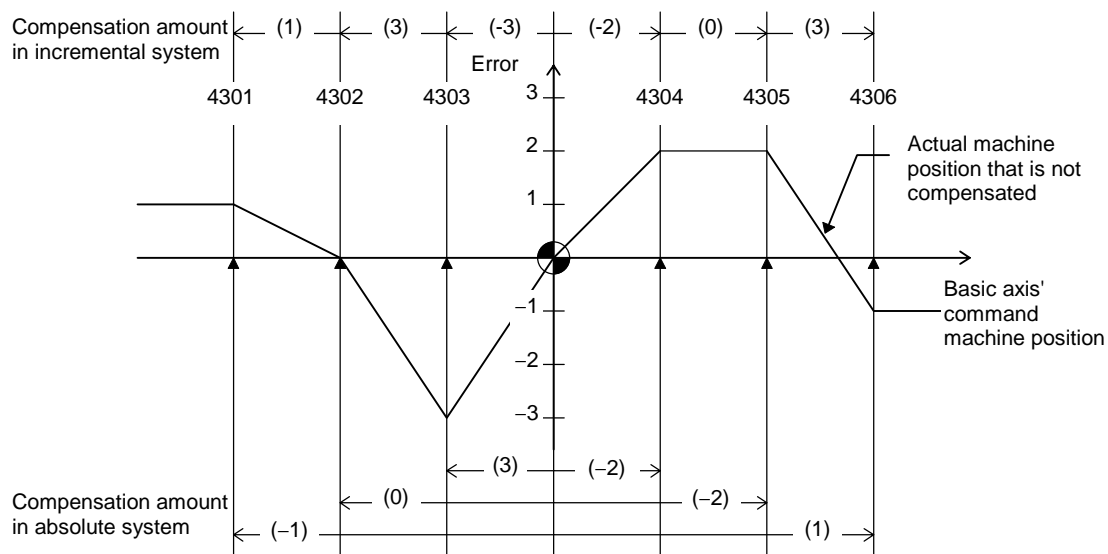

Division point number		4301	4302	4303	4304	4305	4306
Specified machine position		-300.000	-200.000	-100.000	100.000	200.000	300.000
Real machine position		-299.999	-200.000	-100.003	100.002	200.002	299.999
Compensation amount	Incremental	2	6	-6	-4	0	6
	Absolute	-2	0	6	-4	-4	2

rdvno	4303
mdvno	4301
pdvno	4306

If the setting range (mdvno to "pdvno") is exceeded, the compensation will be based on compensation amount at "mdvno" or "pdvno".

### 4.13 Machine Error Compensation

#### 4.13.3 Example in Using a Linear Axis as the Base Axis

**(2) When the range compensated is only the positive range:**

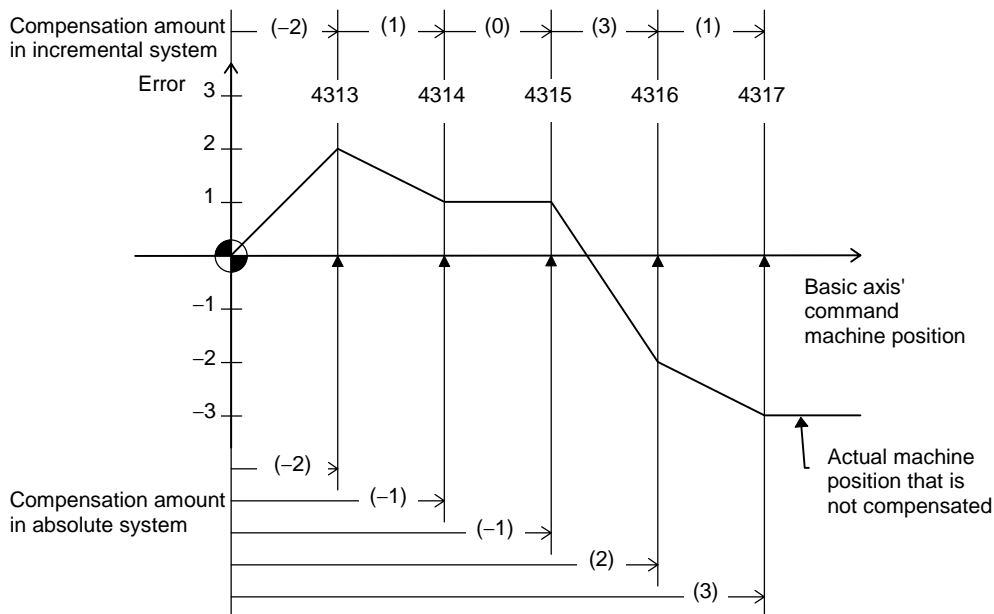

Division point number		4313	4314	4315	4316	4317
Compensation amount	Incremental	-4	2	0	6	2
	Absolute	-4	-2	-2	4	6

rdvno	4312
mdvno	4313
pdvno	4317

If the machine position exceeds "pdvno", the compensation will be based on the compensation amount at "pdvno". If the machine position is negative in this case, no compensation will be executed.

**(3) When the range compensated is only the negative range:**

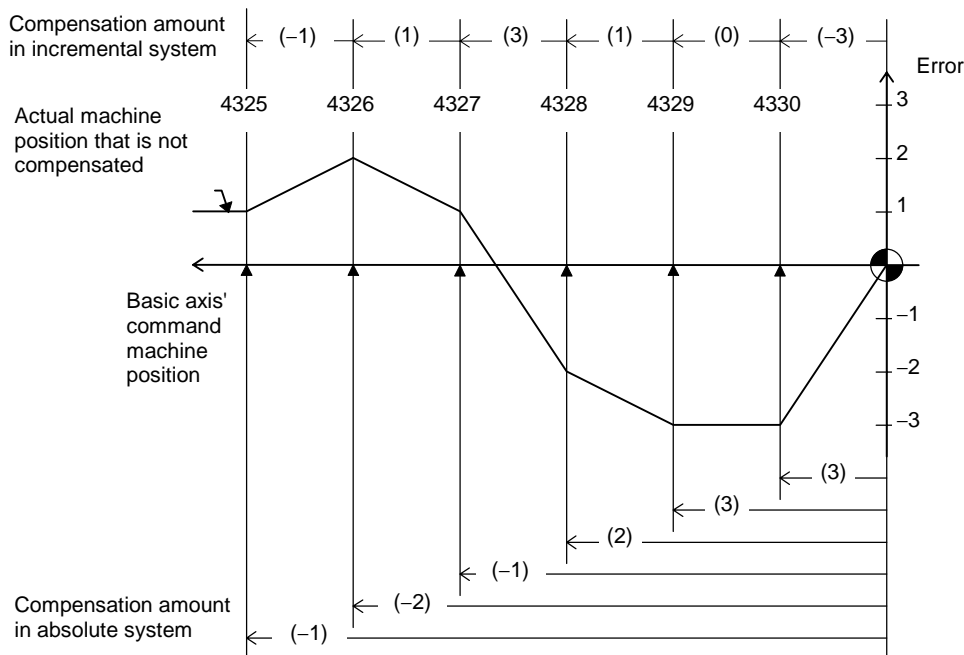

Division point number		4325	4326	4327	4328	4329	4330
Compensation amount	Incremental	-2	2	6	2	0	-6
	Absolute	-2	-4	-2	4	6	6

rdvno	4330
mdvno	4325
pdvno	4330

If the machine position exceeds "mdvno", the compensation will be based on compensation amount at "mdvno".

### 4.13 Machine Error Compensation

#### 4.13.4 Example in Using a Rotation Axis as the Base Axis

**(4) When compensation is executed in a range that contains no reference point:**

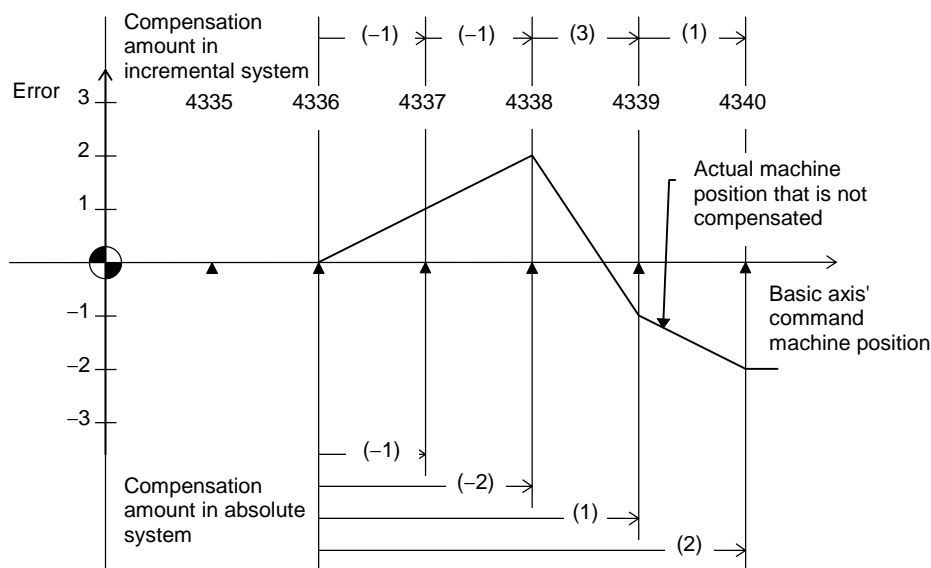

rdvno	4334
mdvno	4336
pdvno	4340

In this case, the compensation is executed in the range from "mdvno" to "pdvno". This setting rule applies also when the compensation is executed in a range which contains negative machine positions and no reference point.

#### 4.13.4 Example in Using a Rotation Axis as the Base Axis

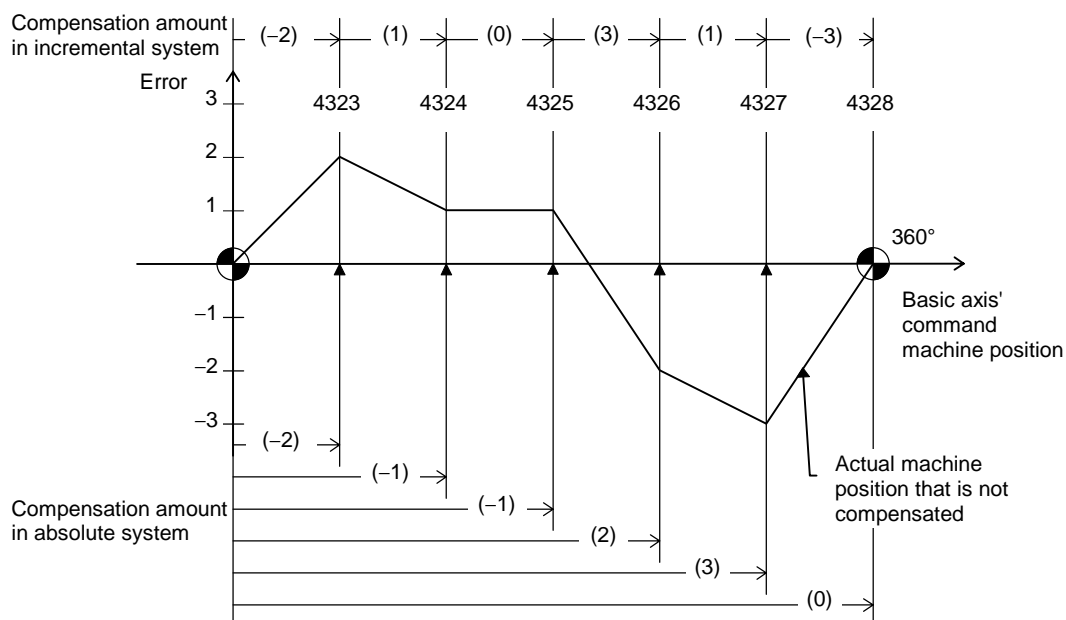

rdvno	4322
mdvno	4323
pdvno	4328

In this case, the sum of the compensation amounts set according to the incremental system is always 0. For the absolute system, the compensation amount at the terminal point (360°) is always 0.

### 5. ABSOLUTE POSITION SETTING PARAMETERS

A password is required to display and set the absolute position parameters. The methods of displaying the absolute position parameters, and the details of the parameters are explained in this chapter.

To set the absolute position parameters, enter the absolute position parameter setting mode with the following method. Refer to the Instruction Manual for details on general screen operations such as displaying and changing the menu and setting the parameters.

- (1) 

Display the menu related to maintenance.
--

 → The menu related to maintenance will appear.
  
- (2) 

Press the menu key	
<table border="1" data-bbox="277 768 437 801"><tr><td>Abs pos set.</td></tr></table>	Abs pos set.
Abs pos set.	

 → A message prompting the password input will appear. If the password has been input once after the power was turned ON, the absolute position parameter menu will appear.
  
- (3) 

Set the password, and press the <table border="1" data-bbox="395 958 491 992"><tr><td>INPUT</td></tr></table> key.	INPUT
INPUT	
MPARA <table border="1" data-bbox="395 1025 491 1059"><tr><td>INPUT</td></tr></table>	INPUT
INPUT	

 → The absolute position parameter menu will appear. Each screen can be selected from this menu.

## 5.1 Absolute Position Set

### 5.1 Absolute Position Set

For parameters indicated with a "\*" in the table, turn the NC power OFF after setting. The setting is validated after the power is turned ON again.

#	Item	Details	Setting range (unit)
	Abs position set	<p>ON : The zero point is initialized. The absolute position detection data can be changed on the screen.</p> <p>OFF : The zero point is not initialized. The absolute position detection data cannot be changed on the screen.</p> <p>This parameter turns OFF when the power is turned ON again.</p>	
1201	Ref position set	<p>0: "1202 Ref position offset" cannot be set after the absolute position is established with zero point initialization.</p> <p>1: Setting zero point initialization is possible.</p> <p>2: Resetting the basic machine coordinate system is possible.</p>	<p>0 to 2</p> <p>"0" is set when the power is turned OFF and when the absolute position is established.</p>
1202	Ref position offset	<p>Set the distance to the absolute position origin point looking from the basic machine coordinate system zero point. Note that after the absolute position is established, this cannot be set if "1201 Ref position set" is 0 or if an absolute position detection alarm has occurred.</p> <p>(Note) Use the following procedure to set the value.</p> <ul style="list-style-type: none"> <li>• Select the detection method with the axis specification parameter "abson", and then turn the power OFF and ON.</li> <li>• Turn "Abs pos set" "ON". (Press the menu "Abs pos set".)</li> <li>• Set "1201 Ref position set" to "1".</li> <li>• Set "Ref position offset".</li> <li>• Turn the power OFF and ON, and then return to the reference point.</li> </ul>	<p>−99999.999 to +99999.999 (mm)</p>
1203	Move amnt in pwr OFF	<p>The difference of the machine positions when the power is turned OFF and turned ON is checked. If the tolerable amount is exceeded, the "Absolute Position Illegal" alarm is output.</p> <p>(Example) When "0" is set: 0.9 x PIT (ball screw pitch) x 1000 [μm]</p>	<p>0 to 99999.999 (mm) (radius value setting)</p> <p>0: Equivalent to ball screw pitch</p>
1204		Not used.	0
1205	No stopper	<p>Select the method for initializing the zero point (press against the machine end stopper or set marked point without using machine end).</p> <p>Always select "0" (stopper method) when carrying out dogless reference point return.</p>	<p>0: Stopper method</p> <p>1: Marked point method</p>
1206	Current lim stopper	<p>Set the current limit value for executing zero point initialization when the machine end stopper method is selected.</p> <p>The setting value is a percentage of the limit current in respect to the stall current.</p> <p>Calculation expression:</p> $(\text{Setting value}) = \frac{(\text{Limit current})}{(\text{Stall current [peak]})} \times 100$	0 to 500 (%)
1207	Max error width	Set the excessive error detection width used when pressing while the absolute position is being set with the machine end stopper method.	0 to 32767 (mm)

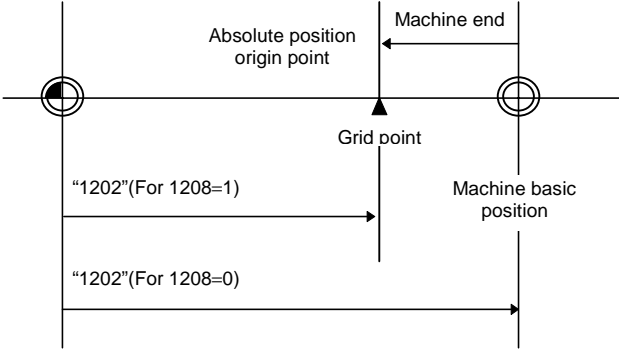

## 5.1 Absolute Position Set

#	Item	Details	Setting range (unit)
1208	Ref position type	<p>Select whether to use a random point (machine end or marked point) or grid point for the absolute position origin point. When using the grid point, operation to move to the grid position is required.</p> 	0: Random point 1: Grid point
1209	Approach amount	<p>When using automatic dog-less type, set the distance (relative distance from pushing point) to start the second push. When "0" is set, a value double to the grspc (grid space) will be set.</p>	0to99999.999 (mm) (Radius value setting)

## 6. MELDAS DIAGNOSIS PARAMETERS

The parameters for the MELDAS diagnosis information are set on this screen.

### (1) Saving the MELDAS diagnosis parameters

1)

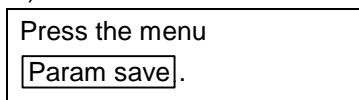

A message confirming whether to execute saving will appear.

2)

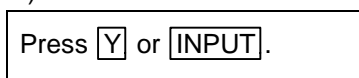

The MELDAS diagnosis parameters will be saved in the NC. After saving, the diagnosis information will be initialized.

To cancel the saving operation, press a key other than  or .

### CAUTION

 Opening another screen is opened without saving the settings made on the MELDAS diagnosis Parameter screen, all of the set diagnosis information parameters will be invalidated.

### (2) List of diagnosis parameters

#	Item	Details	Setting range
8501	Setting effective	Select whether to validate the parameters set on the MELDAS diagn screen.	0: Invalid (The default parameters will be used.) 1: Valid
8502	Check interval	Select the interval for the NC to monitor whether diagnosis information has been created. If 0 is designated, the state will be monitored with the default value (five-second interval).	0 to 9999 (s)
8503	Auto saving	When automatic saving is validated, after creation of diagnosis conditions is detected on the HMI screen, the diagnosis information will be automatically saved onto the personal computer's hard disk.	0: Do not automatically save 1: Automatically save
8504	Start trigger	Select the conditions for starting diagnosis information collection.	0: At power ON 1: At command from program 2: PLC signal
8505	Stop trigger	Select the conditions for stopping diagnosis information collection.	0: Alarm 1: At command from program 2: PLC signal
8506	History suspension	Number of sampled data	0: 1/4 1: 2/4 2: 3/4 3: 4/4
8507	Sampling suspension	Sampling time	0: 1/4 (s) 1: 2/4 (s) 2: 3/4 (s) 3: 4/4 (s)

## 6. MELDAS DIAGNOSIS PARAMETERS

#	Item	Details	Setting range
8508	PLC condition	[Valid only when the stop trigger is the PLC signal] Set the conditions for establishing the PLC stop trigger (PLC signal 1 to PLC signal 4).	0: OR (when one of the signal conditions is valid) 1: AND (when all of the signal conditions are valid)
8509	PLC sgnl name 1	[Valid only when the stop trigger is the PLC signal] PLC signal device name	Bit device usable with NC
8510	PLC sgnl name 2		
8511	PLC sgnl name 3		
8512	PLC sgnl name 4		
8513	PLC sgnl cond 1	[Valid only when the stop trigger is the PLC signal] PLC signal establishment condition	0: OFF → ON 1: ON → OFF
8514	PLC sgnl cond 2		
8515	PLC sgnl cond 3		
8516	PLC sgnl cond 4		
8551	NC key hist num	Set the number of history data items to be sampled.	0 to 9999 items
8552	NC key hist mem	Designate the area for saving the history data on the NC side. (When DRAM is selected, the history data will not be held when the power is turned OFF.)	0: DRAM 1: SRAM
8561	NC alarm hist num	Set the number of history data items to be sampled.	0 to 9999 items
8562	NC alarm hist mem	Designate the area for saving the history data on the NC side. (When DRAM is selected, the history data will not be held when the power is turned OFF.)	0: DRAM 1: SRAM
8563	NC alarm hist sys	Designate the system for sampling the history data.	bit0: 1st system bit1: 2nd system : bit7: 8th system
8571	PLC hist num	Set the number of history data items to be sampled.	0 to 9999 items
8572	PLC hist mem	Designate the area for saving the history data on the NC side. (When DRAM is selected, the history data will not be held when the power is turned OFF.)	0: DRAM 1: SRAM

**(Note 1)** "8509 PLC sgnl name 1" to "8516 PLC sgnl cond 4" are valid only when the PLC signal is selected for "8505 Stop trigger".

## 6. MELDAS DIAGNOSIS PARAMETERS

#	Item	Details	Setting range
8601	Opt-PLC hist num	Set the number of history data items to be sampled.	0 to 9999 items
8602	Opt-PLC hist mem	Designate the area for saving the history data on the NC side. (When DRAM is selected, the history data will not be held when the power is turned OFF.)	0: DRAM 1: SRAM
8611	Opt-PLC hist sgnl 1	PLC signal device name	Bit device usable with NC
8621	Opt-PLC hist sgnl 2		
8631	Opt-PLC hist sgnl 3		
8641	Opt-PLC hist sgnl 4		
8651	Opt-PLC hist sgnl 5		
8661	Opt-PLC hist sgnl 6		
8671	Opt-PLC hist sgnl 7		
8681	Opt-PLC hist sgnl 8		
8701	(Not used)	(For future expansion)	
8702	(Not used)	(For future expansion)	
8711	(Not used)	(For future expansion)	
8712	(Not used)	(For future expansion)	
8721	Modal hist num	Set the number of history data items to be saved.	0 to 9999
8722	Modal hist mem	Designate the area for saving the history data on the NC side. (When DRAM is selected, the history data will not be held when the power is turned OFF.)	0: DRAM 1: SRAM
8723	Modal hist sys	Designate the system for saving the history data.	bit0: 1st system bit1: 2nd system : bit7: 8th system
8731	PREPRO samp num	Designate the number of sampling data to be sampled.	0 to 9999
8732	PREPRO samp mem	Designate the area for saving the sampling data on the NC side. (When DRAM is selected, the history data will not be held when the power is turned OFF.)	0: DRAM 1: SRAM
8733	PREPRO samp axis	Designate the axis for sampling the sampling data.	bit0 : \$1-1st axis bit1 : \$1-2nd axis : bit5 : \$2-1st axis : bit10 : \$3-1st axis : bit14 : \$4-1st axis : bit18 : \$5-1st axis :
8741	ISYNC samp time	Set the sampling time.	0 to 9999 (s)

## 6. MELDAS DIAGNOSIS PARAMETERS

#	Item	Details	Setting range
8742	ISYNC samp cycle	Set the multiplier n value for the sampling cycle calculation expression. (Task cycle) × 2 <sup>n</sup> Calculate the task cycle with 7.1ms.	0 to 8
8743	ISYNC samp mem	Designate the area for saving the sampling data on the NC side. (When DRAM is selected, the history data will not be held when the power is turned OFF.)	0: DRAM 1: SRAM
8744	ISYNC samp axis	Designate the axis for sampling the sampling data.	bit0 : \$1-1st axis bit1 : \$1-2nd axis : bit5 : \$2-1st axis : bit10 : \$3-1st axis : bit14 : \$4-1st axis : bit18 : \$5-1st axis :
8751	MCP samp time	Set the sampling time.	0 to 9999 (s)
8752	MCP samp cycle	Set the multiplier n value for the sampling cycle calculation expression. (Task cycle) × 2 <sup>n</sup> Calculate the task cycle with 3.5ms.	0 to 8
8753	MCP samp mem	Designate the area for saving the sampling data on the NC side. (When DRAM is selected, the history data will not be held when the power is turned OFF.)	0: DRAM 1: SRAM
8754	MCP samp spindle	Designate the spindle for sampling the sampling data. (Set the logical sum for which the corresponding system's bits are ON (1).)	bit0: 1st spindle bit1: 2nd spindle : bit5: 6th spindle
8755	MCP samp axis	Designate the axis for sampling the sampling data. (Set the logical sum for which the corresponding system's bits are ON (1).)	bit0 : \$1-1st axis bit1 : \$1-2nd axis : bit5 : \$2-1st axis : bit10 : \$3-1st axis : bit14 : \$4-1st axis : bit18 : \$5-1st axis :

## Revision History

Sub-No.	Date of revision	Revision details
*	October, 2000	First edition created.

## **Notice**

Every effort has been made to keep up with software and hardware revisions in the contents described in this manual. However, please understand that in some unavoidable cases simultaneous revision is not possible.

Please contact your Mitsubishi Electric dealer with any questions or comments regarding the use of this product.

## **Duplication Prohibited**

This instruction manual may not be reproduced in any form, in part or in whole, without written permission from Mitsubishi Electric Corporation.

© 2000 MITSUBISHI ELECTRIC CORPORATION  
ALL RIGHTS RESERVED.



HEAD OFFICE: MITSUBISHI DENKI BLD. MARUNOUCHI, TOKYO 100-0005 TEL:03-218-3426

---