

PowerFlex 755TM IP00 EMC C2 Filter Unpacking and Lifting Instructions

Catalog Number 20-750-MEMCC2-F8910

IMPORTANT The EMC C2 filter is used for PowerFlex 755T product installations that require compliance with CE EN61800-3 Category C2 for conducted emissions only. See the PowerFlex® 755TM IP00 Open Type Kits Installation Instructions, publication [750-IN101](#), for details.

Before You Begin

Complete these tasks before you unpack and lift an EMC C2 filter out of the shipping container.

- Prepare all equipment and hardware that is used to lift the module. A hoist, straps, and J-hooks with a lockable clasp capable of supporting the EMC C2 filter weight are recommended. See EMC C2 Filter Weight on page [2](#).
- Install the required components from the EMC C2 filter input bus bars kit (catalog number 20-750-MEMCC2-IPBB) in the enclosure before you install the EMC C2 filter. See the PowerFlex 755TM IP00 Open Type Kits Installation Instructions, publication [750-IN101](#), for detailed instructions.

IMPORTANT This kit includes three ferrite cores, which are installed on wire harnesses in the AC precharge system. See the PowerFlex 755TM IP00 Open Type Kits Installation Instructions, publication [750-IN101](#), for details.

This kit includes the hardware for connecting the EMC C2 filter to the required EMC C2 bus bar kits, which are ordered and shipped separately.

Unpack and Inspect the Filter

Upon delivery, follow these steps to unpack and inspect the filter.

IMPORTANT Delivery of equipment from Rockwell Automation to the carrier is considered delivery to the buyer. The carrier becomes liable for any damage that occurs during transit. It is the responsibility of the buyer to notify the proper party if damage is found. The buyer can forfeit any right to recovery for loss or damages by failing to comply with these steps.

1. Inspect the shipping container for any damage that occurred during transit.
2. Remove the cover of the shipping container.
3. Remove the protective packing materials.
4. Inspect the filter for any damage. Verify that the insulation on the filter bus bars is not cracked or damaged.
5. If damage to the filter exists, contact the carrier that delivered the shipment and your Rockwell Automation sales representative to schedule an inspection.
6. Retain all product packaging for review by the carrier.

Read the Lifting Precautions

Read these precautions before attempting to lift the EMC C2 filter.



ATTENTION: All equipment and hardware that is used to lift the filter must be properly sized and rated to lift and hold the weight of the filter safely. To guard against possible personal injury or equipment damage:

- Inspect all hardware for proper attachment before the filter is lifted.
- Do not allow any part of the filter or lift equipment to contact electrically charged conductors or components.
- Do not subject the filter to high rates of acceleration or deceleration during a lift or transportation.
- Do not allow personnel or their limbs directly beneath the filter during a lift.

EMC C2 Filter Weight

All lifting equipment must support the approximate EMC C2 filter weight of 31.75 kg (70 lb).

Lift the EMC C2 Filter

Follow these steps to lift the filter.

1. Remove the packing materials and hardware that secures the filter to the pallet.
2. Verify that you have completed the tasks in the Before You Begin section on page 1.
3. Insert and secure the appropriately rated lifting hardware in a designated lifting hole on both sides of the filter chassis (as identified in the illustrations). There are three sets of lifting holes that can be used; the holes are opposite each other on the two metal flanges.



ATTENTION: To guard against equipment damage, verify that the hardware is securely connected to the correct lifting holes in the metal flanges as shown. Do NOT use the bus bars to lift the filter.

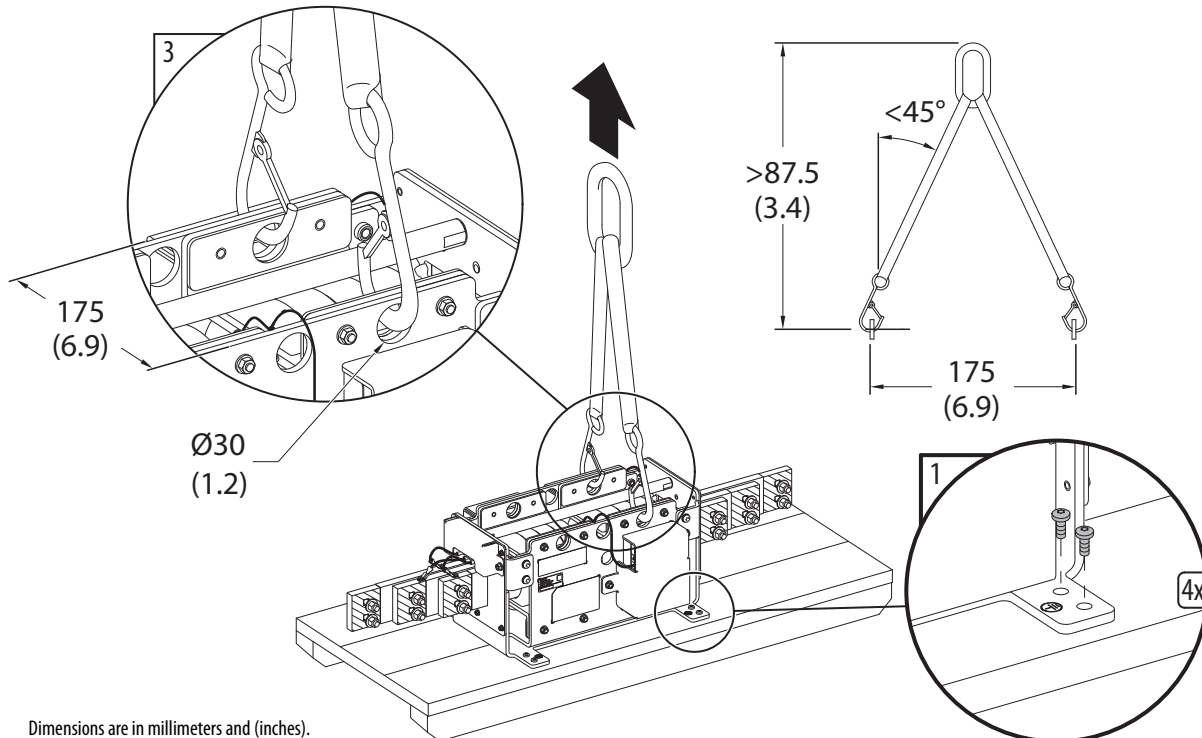

Dimensions are in millimeters and (inches).

IMPORTANT When lifting the filter by the outer-most holes on the metal flange and the filter approaches the full upright (vertical) position, the weight can shift and cause the filter to swing unexpectedly. When using the outer-most lifting holes, control the movement of the filter as it is lifted from the shipping container.

4. Slowly lift the filter to an upright position and carefully transport the module to the installation location.
5. Continue with the EMC C2 filter installation instructions that are contained in the PowerFlex 755TM IP00 Open Type Kits Installation Instructions, publication [750-IN101](#).

Additional Resources

These documents contain additional information concerning related products from Rockwell Automation.

Resource	Description
PowerFlex 750-Series Products with TotalFORCE® Control Installation Instructions, publication 750-IN100	Provides procedures for the mechanical and electrical installation of PowerFlex 750-Series products with TotalFORCE control. This manual includes the basic steps to transport, position, and join the product enclosures, to make internal electrical connections, to connect power and the motor, and to wire basic I/O.
PowerFlex 755TM IP00 Open Type Kits Installation Instructions, publication 750-IN101	Provides instructions to install IP00 Open Type kits in user-supplied enclosures.
PowerFlex 755TM IP00 Open Type Kits Technical Data, publication 750-TD101	Provides detailed information on: <ul style="list-style-type: none"> • Kit selection • Kit ratings and specifications • Option specifications
PowerFlex 750-Series Products with TotalFORCE Control Hardware Service Manual, publication 750-TG100	Provides detailed information on: <ul style="list-style-type: none"> • Preventive maintenance • Component testing • Hardware replacement procedures
Industrial Automation Wiring and Grounding Guidelines, publication 1770-4.1	Provides general guidelines for installing a Rockwell Automation industrial system.
Product Certifications website, http://www.rockwellautomation.com/global/certification/overview.page	Provides declarations of conformity, certificates, and other certification details.

You can view or download publications at <http://www.rockwellautomation.com/global/literature-library/overview.page>. To order paper copies of technical documentation, contact your local Allen-Bradley distributor or Rockwell Automation sales representative.

Rockwell Automation Support

Use the following resources to access support information.

Technical Support Center	Knowledgebase Articles, How-to Videos, FAQs, Chat, User Forums, and Product Notification Updates.	https://rockwellautomation.custhelp.com/
Local Technical Support Phone Numbers	Locate the phone number for your country.	http://www.rockwellautomation.com/global/support/get-support-now.page
Direct Dial Codes	Find the Direct Dial Code for your product. Use the code to route your call directly to a technical support engineer.	http://www.rockwellautomation.com/global/support/direct-dial.page
Literature Library	Installation Instructions, Manuals, Brochures, and Technical Data.	http://www.rockwellautomation.com/global/literature-library/overview.page
Product Compatibility and Download Center (PCDC)	Get help determining how products interact, check features and capabilities, and find associated firmware.	http://www.rockwellautomation.com/global/support/pcdc.page

Documentation Feedback

Your comments will help us serve your documentation needs better. If you have any suggestions on how to improve this document, complete the How Are We Doing? form at http://literature.rockwellautomation.com/idc/groups/literature/documents/du/ra-du002_-en-e.pdf.

Rockwell Automation maintains current product environmental information on its website at <http://www.rockwellautomation.com/rockwellautomation/about-us/sustainability-ethics/product-environmental-compliance.page>.

Allen-Bradley, PowerFlex, Rockwell Automation, Rockwell Software, and TotalFORCE are trademarks of Rockwell Automation, Inc. Trademarks not belonging to Rockwell Automation are property of their respective companies.

Rockwell Otomasyon Ticaret A.Ş., Kar Plaza İş Merkezi E Blok Kat:6 34752 İçerenköy, İstanbul, Tel: +90 (216) 5698400

www.rockwellautomation.com

Power, Control and Information Solutions Headquarters

Americas: Rockwell Automation, 1201 South Second Street, Milwaukee, WI 53204-2496 USA, Tel: (1) 414.382.2000, Fax: (1) 414.382.4444
Europe/Middle East/Africa: Rockwell Automation NV, Pegasus Park, De Kleetlaan 12a, 1831 Diegem, Belgium, Tel: (32) 2 663 0600, Fax: (32) 2 663 0640
Asia Pacific: Rockwell Automation, Level 14, Core F, Cyberport 3, 100 Cyberport Road, Hong Kong, Tel: (852) 2887 4788, Fax: (852) 2508 1846

