

IGBT Discrete Devices

Focus on Energy Saving



Product Features

- IGBT Wafer uses advanced Trench + FS technology
- 600V/650V/1200V/1800V Voltage Resistance
- High Power Density
- Low Switching Loss
- Low Conduction Loss
- $T_{jmax}=175^{\circ}C$
- V_{cesat} Positive Temperature Coefficient
- Compliant with RoHS

Package Types



TO-252



TO-263



TO-220F



TO-220



TO-247



TO-3P



TO-247Plus



TO-247-4



TO-264



IITO-220

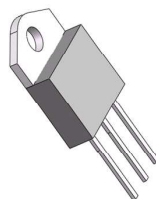

IITO-3P

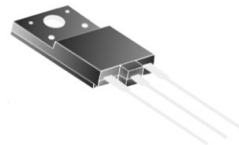

TO-3PF

Surface Mount Series (DPAK , D2PAK)

Focus on Energy Saving



Surface Mount Series products, commonly used in the industry SMD package, with a moisture sensitivity level of MSL1 . The IGBT chip adopts Trench Field Stop technology, which improves the chip power density and has low on-state and switching losses.

The maximum current of this series of products can reach 30A , and the future plan is to achieve a 40A level to meet the demand for high power and small size.

Product Features

- High Switching Speed
- Low Conduction Loss
- High Power Density
- High Short Circuit Tolerance

Package Forms



DPAK



D2PAK

Application Fields



Fan



Refrigerator



Industrial Motor Drive

Product List

Package Form	Voltage Level (V)	Current Specification (A)	Product Model	Vcesat@typ. Tj=25 °C	Vth@typ. Tj=25 °C	tsc@Vge=15V Tj=150 °C	Tjmax
DPAK	600	4	XNM4N60T	2.4V	5.9V	5us	175 °C
		6	XNM6N60T	1.8V	5.9V	5us	
D2PAK	600	6	XNA6N60T	1.8V	5.9V	5us	
		10	XNA10N60T	1.9V	5.9V	5us	
		15	XNA15N60T	1.7V	5.5V	5us	
	650	20	XNA20N65T	1.55V	5.7V	5us	
		30	XNA30N65T	1.75V	5.4V	5us	

TO-220 Series

Focus on Energy Saving



TO-220 Through-hole series products with various package forms; customized internal insulation packaging combined with system applications, insulation voltage withstand >2500V; omitting insulation pads between the device and the heat sink, simplifying the production process.

The IGBT chip adopts Trench Field Stop technology, which improves the chip power density and has low on-state and switching losses.

Product Features

- High Switching Speed
- Low Conduction Loss
- High Power Density
- High Short Circuit Tolerance

Package Forms



TO-220F



TO-220



IITO-220 (Internal Insulation)

Application Fields



Fan



Portable Energy Storage



Industrial Motor Drive

Product List

Package Form	Voltage Level (V)	Current Specification (A)	Product Model	Vcesat@typ. Tj=25 °C	Vth@typ. Tj=25 °C	tsc@Vge=15V Tj=150 °C	Tjmax
TO-220F	600	6	XNF6N60T	1.8V	5.9V	5us	175 °C
		15	XNF15N60T	1.7V	5.5V	5us	
		20	XNF20N60T	1.55V	5.7V	5us	
		30	XNF30N65T	1.75V	5.4V	5us	
TO-220	600	15	XNT15N60T	1.7V	5.5V	5us	
		20	XNT20N60T	1.55V	5.7V	5us	
		30	XNT30N65T	1.75V	5.4V	5us	
IITO-220 (Internal Insulation)	600	15	XNT15N60TI	1.7V	5.5V	5us	
		24	XNT24N60TI	1.7V	5.5V	10us	
TO-220	1200	15	XNT15N120T	2.5V	5.9V	5us	

TO-247 Series

Focus on Energy Saving



TO-247 Series High Power Products, commonly used packaging in the industry, classified into industrial grade and automotive grade.

The IGBT chip adopts Trench Field Stop technology, which improves the chip power density and has low on-state and switching losses.

The maximum current of this series of products can reach 120A , and the future plan is to achieve 160A level, meeting the demand for high power and small size.

Product Features

- High Switching Speed
- Low Conduction Loss
- High Power Density

Application Fields



Induction Heating



Energy Storage



Variable Frequency Air Conditioning

Package Forms



TO-247-3L



TO-247PLUS-3L



Solar Energy



Charging Station



New Energy Vehicles

Product List

Package Form	Voltage Level (V)	Current Specification (A)	Product Model	Vcesat@typ. Tj=25 °C	Vth@typ. Tj =25 °C	tsc@Vge =15V Tj =150 °C	Tjmax
TO-247-3L	600	20	XNS20N60T	1.55V	5.7V	5us	175 °C
		40	XNS40N60T	1.8V	5.5V	10us	
	650	30	XNS30N65T	1.75V	5.4V	5us	
			40	XNS40N65TH3	1.6V	4.1V	
			XNS40N65TF3	1.45V	4.8V	-	
		50	XNS50N65TL3	1.7V	5.2V	5us	
			XNS50N65T H3	1.5V	4.0V	-	
		60	XNS60N65TM	1.7V	6.0V	5us	
		75	XNS75N65TF3	1.4V	5.0V	-	
			XNS75N65TL3	1.2V	5.0V	-	
		80	XNS80N65TB	1.4V	5.2V	-	
			XNS80N65TSH3	1.8V	5.8V	-	
	1200	15	XNS15N120T	1.9V	5.8V	10us	
			XNS25N120T	1.7V	5.8V	10 us	
		40	XNS40N120T	1.7V	5.8V	10us	
			XNS40N120TH	2.0V	5.8V	10us	
50		XNS50N120TL2	1.7V	5.9V	10 us		
1100	30	XNS30N110TR3	1.6V	6.0V	5us		
1800	40	XNS40N180TR	2.1V	5.0V	-		
TO-247PLUS-3L	1200	75	XNU75N120TF2	1.75V	5.8V	-	
		140	XNU140N120TF2	1.75V	5.8V	-	
	650	120	XNU120A65TL3	1.6V	5.2V	5us	

TO-3P Series

Focus on Energy Saving



TO-3P packaging series products, commonly used packaging in the industry; back-insulated 3PF package, insulation withstand voltage >3500V .

The IGBT chip adopts Trench Field Stop technology, which improves the chip power density and has low on-state and switching losses.

Product Features

- High Switching Speed
- Low Conduction Loss
- High Power Density
- High Short Circuit Tolerance

Package Forms



TO-3P

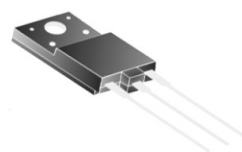

TO-3PF

Application Fields



Induction Heating



Variable Frequency Air Conditioning



Portable Energy Storage

Product List

Package Form	Voltage Level (V)	Current Specification (A)	Product Model	Vcesat@typ . Tj =25 °C	Vth@typ . Tj =25 °C	tsc@Vge =15V Tj =150 °C	Tjmax
TO-3P	600	40	XNP40N60T	1.9V	5.7V	5us	175 °C
		50	XNP50N60T	1.9V	5.5V	5us	
	1350	25	SP25N135T	1.75V	5.9V	5us	
TO-3PF	600	20	XNQ20N60T	1.7V	5.5V	10us	
		40	XNQ40N60TR	1.8V	5.5V	5us	



Driver IC

For MOSFET/IGBT drivers, Semiconductor Power has developed driver ICs that are the first of their kind in China. They have high reliability and wide compatibility, and can meet the diverse needs of motor drive and power conversion in fields such as consumer electronics, home appliances, industry, and new energy.

Semiconductor Power's driver ICs have rich features such as overcurrent protection, undervoltage protection, overtemperature shutdown, anti-shoot-through, and dead time control. They have stronger driving capability and can integrate bootstrap diodes, helping customers simplify their systems and save costs.

Product list

Type	Model	Channel	Voffset Max(V)	IO +/- (mA)	Deadtime (ns)	ton/off (ns)	BSD	Package
HVIC								
Half Bridge	XN2304S	2	600	290/600	100	250/250	N/A	SOP8
	XN2101S	2	600	290/600	N/A	90/90	N/A	SOP8
	XN21011S	2	600	10/20	300	380/380	✓	SOP8
	XN21012S	2	600	50/100	300	380/380	✓	SOP8
	XN2001S	2	200	3000/3000	500	60/60	N/A	SOP8
Three Phase	XN2136S	6	600	200/350	300	400/400	N/A	SOP28
	XN21364S	6	600	200/350	300	400/400	N/A	SOP28
	XN7888	6	200	350/700	500	350/350	N/A	TSSOP20
	XN1134S	6	60	1000/1000	500	30/30	✓	SSOP24
Low Side Driver								
Single Channel	XN44272L	1	25	1500/1500	N/A	50/50	N/A	SOT23
	XN7517L	1	25	5000/5000	N/A	15/15	N/A	SOT23
	XN44176S	1	25	800/1750	N/A	50/50	N/A	SOP8
Dual Channel	XN7524S	2	25	5000/5000	N/A	15/15	N/A	SOP8
	XN7525S	2	25	5000/5000	N/A	15/15	N/A	SOP8
Motor Driver								
Dual H Bridge	XN8549S	N/A	25	1000/1000	N/A	N/A	N/A	SOP10

Application areas

- Home appliances
- Fans, pumps
- Power tools
- Industrial frequency conversion servo
- Induction heating
- New energy



XN2304S, 2101S, 21011S, 21012S

Focus on Energy Saving



The XN23XX, 21XX series products are high voltage, high speed MOSFET/IGBT drivers that provide interdependent high-side and low-side output drive signals. They are implemented with mature and reliable, anti-lock high voltage CMOS technology to achieve a stable single-chip structure.

The logic input level is compatible with standard CMOS or LSTTL outputs, with a minimum support of 3.3V logic. The output driver has a high pulse current buffer stage to reduce driver cross-conduction. The floating channel can be used to drive N-type MOSFET/IGBT configurations, with a working voltage of up to 650V.

Product Characteristics

- High-side Floating Channel Bootstrap Power Supply
- Operating voltage up to 650V
- Built-in bootstrap diode (XN21011S, XN21012S)
- Drive voltage range: 10V-20V
- Compatible with 3.3V, 5V, and 15V logic inputs
- Features include undervoltage lockout, anti-shoot-through, and built-in dead time
- Transient negative voltage and dv/dt withstand capability
- Transmission delay matching between two channels
- High-side and low-side inputs and outputs are in phase
- SOP8 package

Main Parameters

- Maximum operating voltage: 650V
- Output drive current:
 - - 290mA/600mA (XN2304S, XN2101S)
 - - 10mA/20mA (XN21011S)
 - - 50mA/100mA (XN21012S)

Application Areas



Motor



Fan



Pump



Home appliances

Package Information

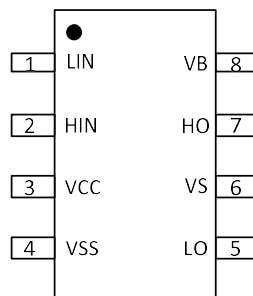
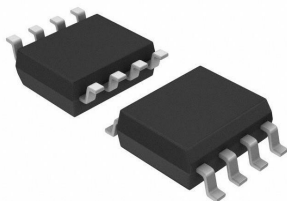

XN2304S

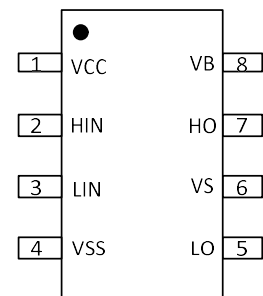

XN2101S, 21011S, 21012S

Application Diagram

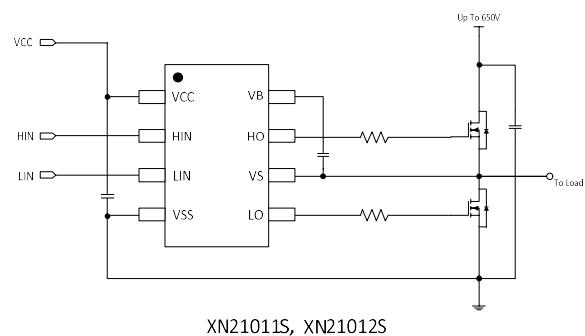
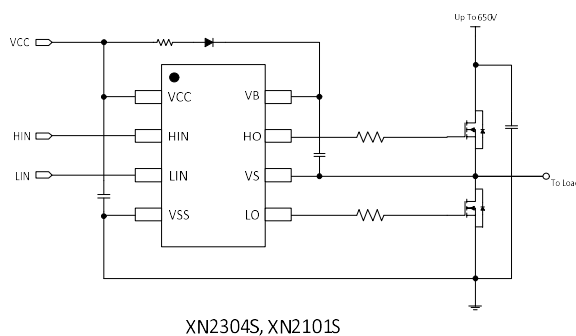

XN2001S

Focus on Energy Saving



XN2001S is a 200V high-speed MOSFET/IGBT driver that provides interdependent high-side and low-side output drive signals. It features a stable single-chip construction using mature and reliable, anti-lock high-voltage CMOS technology.

The logic input level is compatible with standard CMOS or LSTTL outputs, with a minimum support of 3.3V logic. The output driver pulse current can reach up to 3A to reduce switching losses. The floating channel can be used to drive N-type MOSFET/IGBT in high-side configurations, with a working voltage of up to 200V.

Product Characteristics

- High-side Floating Channel Bootstrap Power Supply
- Operating voltage can reach 200V
- Drive voltage range: 10V-20V
- Compatible with 3.3V, 5V, and 15V logic inputs
- Features include undervoltage lockout, anti-shoot-through, and built-in dead time
- Transient negative voltage and dv/dt withstand capability
- Transmission delay matching between two channels
- High-side and low-side inputs and outputs are in phase
- SOP8 package

Main Parameters

- Maximum operating voltage: 200V
- Output drive current: 3A/3A
- Output drive voltage: 10V-20V
- Turn-on/off delay (typical): 60ns/60ns
- Dead time (typical): 500ns

Application Areas



Motor



Electric vehicles



Power tools



Small household appliances

Package Information

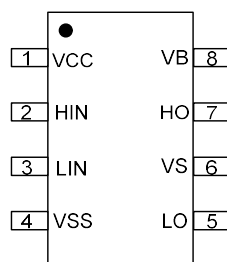
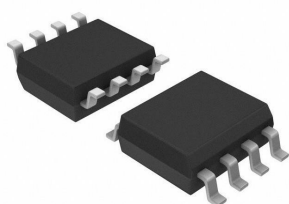

Application Diagram

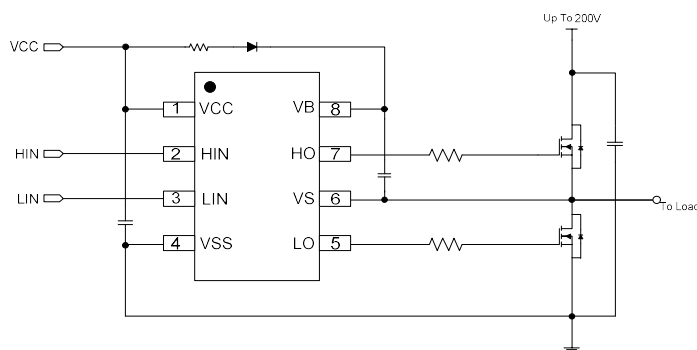



XN2136S, 21364S

XN2136XS is a three-phase high-voltage, high-speed MOSFET/IGBT driver, which adopts mature and reliable high-voltage CMOS technology to achieve a stable single-chip structure.

The input level is compatible with CMOS or LSTTL output. Overcurrent protection is achieved by sampling the detection resistor and controlling the shutdown of the six output terminals. It provides an open-drain FAULT signal to indicate a fault occurrence and automatically clears it after a programmable delay. The output stage has a high pulse current buffer stage to reduce driver cross-conduction. The floating channel is used to drive high-side MOSFET/IGBT with a working voltage of up to 650V.

Product Characteristics

- High-side Floating Channel Bootstrap Power Supply
- 3-phase, 6-channel, operating voltage up to 650V
- Drive voltage range: 10V-20V (XN2136S)
13V-20V (XN21364S)
- Compatible with 3.3V and 5V logic inputs
- Multiple functions: undervoltage lockout, enable, overcurrent protection, programmable Fault output time, anti-shoot-through, built-in dead time, etc.
- High stability: transient negative voltage tolerance, high dv/dt tolerance
- High-side and low-side input-output logic options:
Positive logic / in-phase (XN2136S)
Negative logic / reverse (XN21364S)
- SOP28 Package

Main Parameters

- Maximum operating voltage: 650V
- Output Drive Current: 200mA/350mA
- Undervoltage Threshold:
- 8.1V/9V (XN2136S)
- 9.8V/11.7V (XN21364S)

Package Information



Application Areas



Home Appliances



Fan



Water Pump



Power Supply

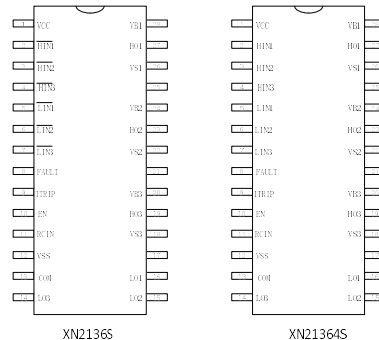

Application Diagram

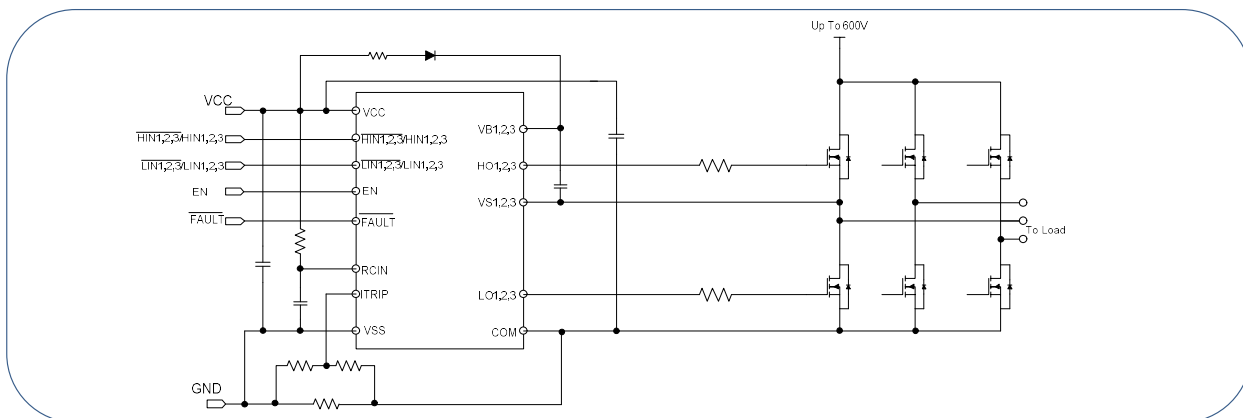

XN7888



XN7888 is a high-speed MOSFET/GBT driver with a voltage rating of 200V. It provides 3 sets of interdependent high-side and low-side output drive signals. It features a stable single-chip construction using mature and reliable anti-lock high-voltage CMOS technology.

The logic input level is compatible with standard CMOS or LSTTL outputs, with a minimum support of 3.3V logic. The output driver has a high pulse current buffer stage to reduce driver cross-conduction. The floating channel can be used to drive N-type MOSFET/IGBT in high-side configuration, with a working voltage of up to 200V.

Product Characteristics

- High-side Floating Channel Bootstrap Power Supply
- Operating voltage can reach 200V
- Drive voltage range: 10V-20V
- Compatible with 3.3V, 5V, and 15V logic inputs
- Features include undervoltage lockout, anti-shoot-through, and built-in dead time
- Transient negative voltage and dv/dt withstand capability
- Transmit Delay Matching Between Channels
- High-side and low-side inputs and outputs are in phase
- TSSOP20 Package

Main Parameters

- Maximum operating voltage: 200V
- Output Drive Current: 350mA/700mA
- Output drive voltage: 10V-20V
- Turn-On and Turn-Off Delay (Typical): 350ns/350ns
- Dead time (typical): 500ns

Application Areas



Motor



Electric vehicles



Power tools



Small household appliances

Package Information

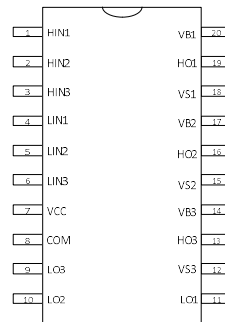
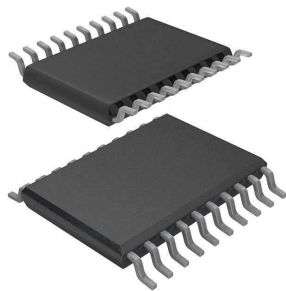

Application Diagram

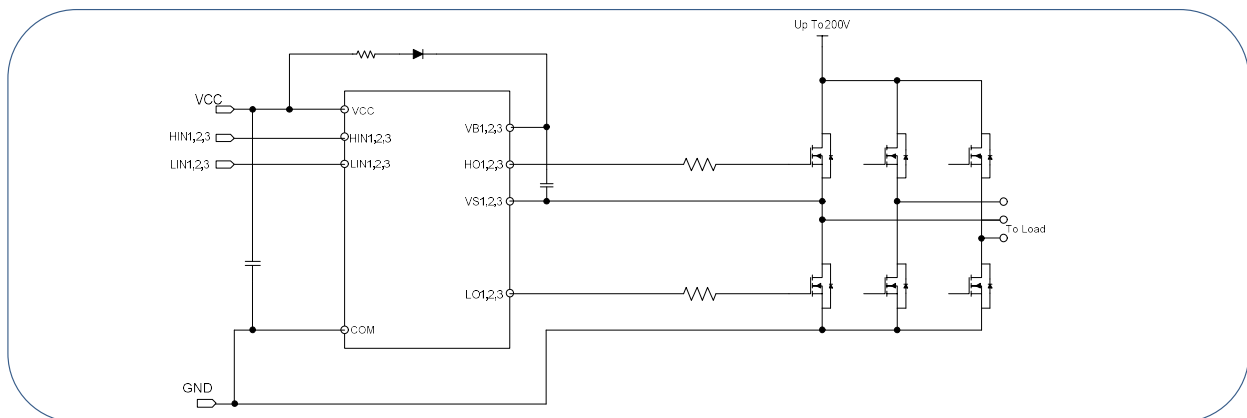



XN1134S

XN1134S is a three-phase, 60V high-speed MOSFET driver that utilizes mature and reliable, anti-lock high-voltage CMOS technology to achieve a stable single-chip construction.

The logic input level is compatible with standard CMOS or LSTTL output, with a minimum support of 3.3V logic. The output driver pulse current can reach up to 1A to reduce switching losses. The floating channel can be used to drive high-side configured N-type MOSFETs, with a working voltage of up to 45V.

Product Features

- High-side floating channel bootstrap power supply
- 3 phase 6 channel, operating voltage up to 45V
- Driving voltage range 5V-18V
- Integrated bootstrap diode (BSD)
- 3.3V , 5V and 15V logic input compatible
- Features include undervoltage lockout, enable, anti-shoot-through, built-in dead time, etc.
- High-side and low-side inputs and outputs are in phase
- Integrated 5V output voltage regulator
- SSOP24 package

Key Parameters

- Maximum operating voltage: 45V
- Output drive current: 1A/1A
- Voltage regulator @IO=60mA : 4.85V (min), 5V (typ), 5.15V (max)

Application areas



Motor Electric vehicle Power tools Small appliances

Package information

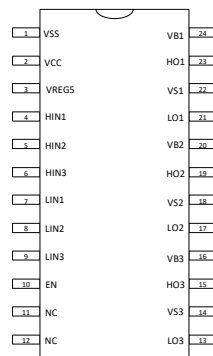

Application diagram

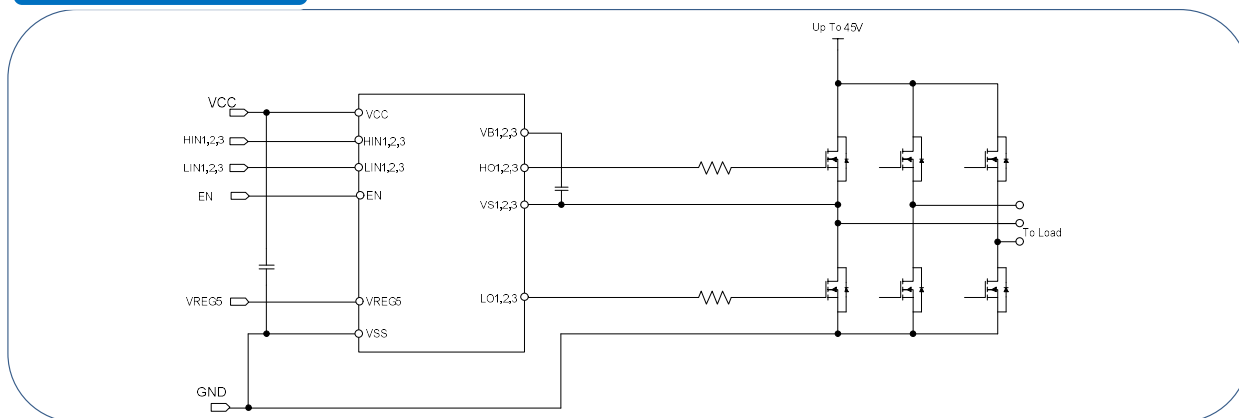

XN44272L, 7517L

Focus on Energy Saving



XN44272L and XN7517L are single-channel high-speed low-side gate drivers that can efficiently drive MOSFET/IGBT with a wide power supply range.

Logic input levels are compatible with standard CMOS or LSTTL outputs, with a minimum support of 3.3V logic. The output driver stage has a maximum output current of 5A, rail-to-rail output voltage, and minimal transfer delay.

Product Features

- Maximum Power Supply Voltage: 25V
- Peak Drive Source Current and Sink Current
- Drive Voltage Range
 - - 13V-20V (XN44272L)
 - - 4.5V-20V (XN7517L)
- Under-voltage lockout
- 3.3V, 5V, and 15V logic inputs compatible
- Dual-input design (XN7517L)
- Input negative voltage tolerance (XN7517L)
- SOT23-5L package

Key Parameters

- Output drive current:
 - -1.5A/1.5A (XN44272L)
 - -5A/5A (XN7517L)

Application areas



PFC



Induction heating



New energy



Small household appliances

Package information

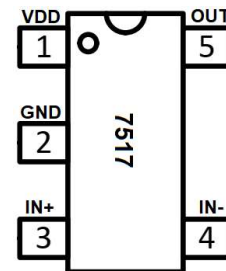
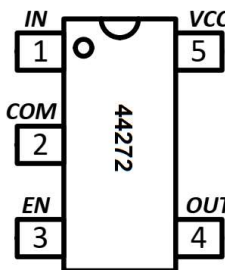

Application diagram

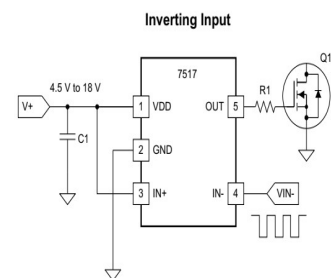
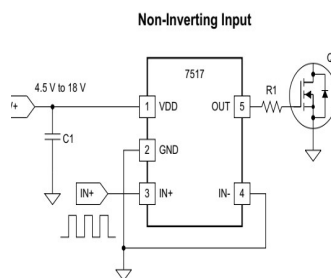
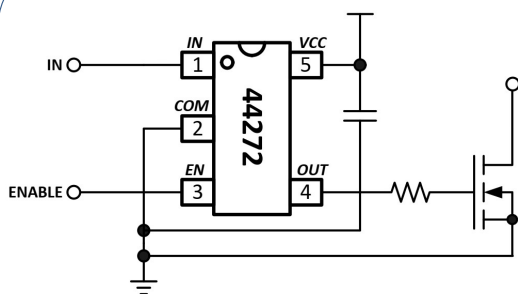

XN7524S, 7525S

XN7524S and XN7525S are dual-channel high-speed low-side gate drivers that efficiently drive MOSFET/IGBT with a wide power supply range.

The logic input level is compatible with standard CMOS or LSTTL output and supports a minimum of 3.3V logic. The output driver stage has a maximum output current of 5A, rail-to-rail output voltage, and minimal propagation delay.

Product Features

- Maximum Power Supply Voltage: 25V
- Peak Drive Source Current and Sink Current
- Wide Drive Voltage Range: 4.5V-20V
- Undervoltage lockout, independent dual-channel enable (EN)
- 3.3V, 5V, and 15V logic input compatible
- Transmission delay matching between two channels
- Negative voltage tolerance at input terminal
- Input-output logic options:
 - Dual-channel positive logic / in-phase (XN7524S)
 - Positive logic / in-phase + Negative logic / inverse (XN7525S)
- SOP8 package

Key Parameters

- Output drive current: 5A/5A

Application areas



PFC



Induction heating



New energy



Small household appliances

Package information

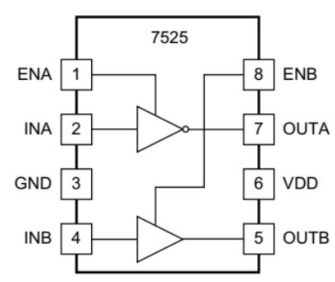
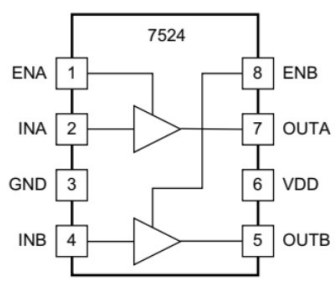
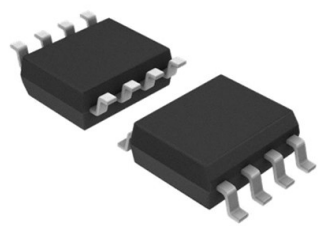

Application diagram

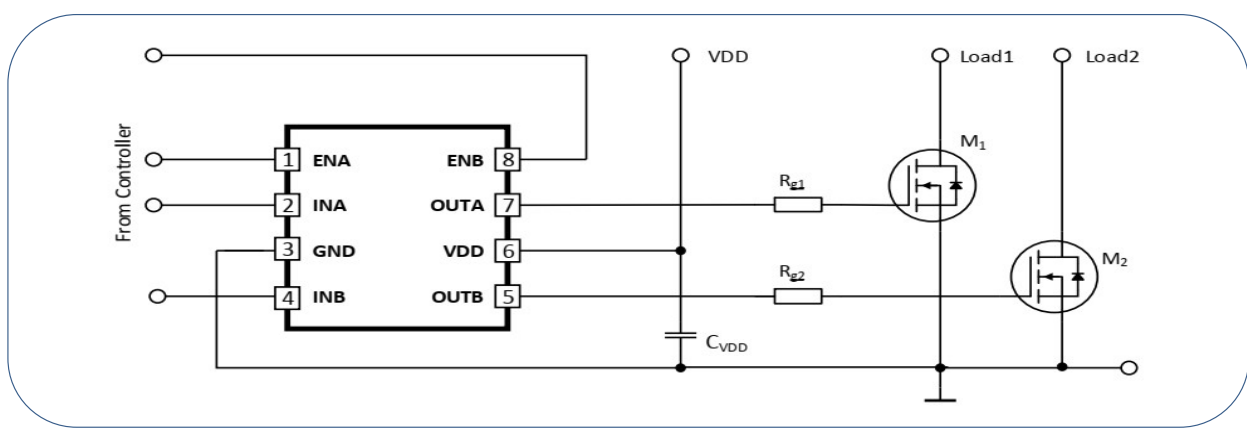

XN8549S – Motor Driver

XN8549S is a dual-channel low saturation voltage forward/reverse motor drive IC suitable for driving stepper motors in 12V systems in full-step mode. Each H-bridge output consists of a pair of N-channel and P-channel MOSFETs for regulating coil current. The IC features undervoltage lockout and overtemperature shutdown functions internally, and it also provides a low power sleep mode.

Product Features

- Maximum supply voltage: 25V
- Wide supply voltage range: 4V-20V
- DMOS output stage
- Single power supply
- Undervoltage lockout, overtemperature protection
- Low power sleep mode
- SOP10 package

Key Parameters

- Maximum output current: 1A
- Output impedance: 1.25Ω

Application areas

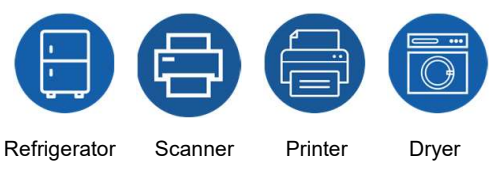

Package information

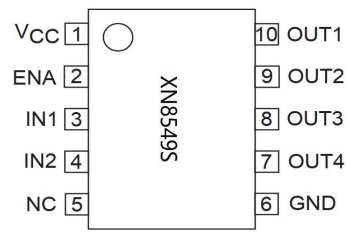
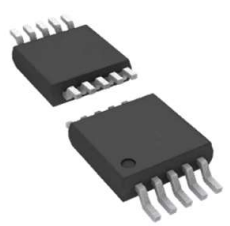

Application diagram

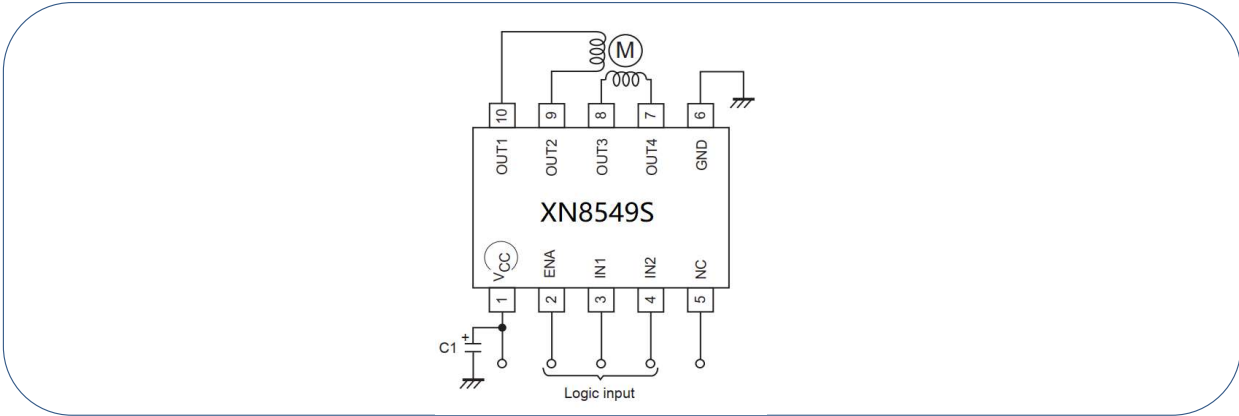



Smart Power Module - IPM

Product Features

- Utilizing Trench FS-IGBT technology and FRD-MOSFET technology,
- highly integrated chip technology developed independently by the company,
- power semiconductor devices IGBT/MOSFET.
- The application range covers power from 0.3KW to 5KW, providing different topology choices.
- It reduces time to market, improves reliability, lowers system costs,
- increases power density, and reduces space requirements.
- It improves manufacturing processes and complies with RoHS and REACH regulations.
- $T_{jmax}=150^{\circ}C$.

Package information

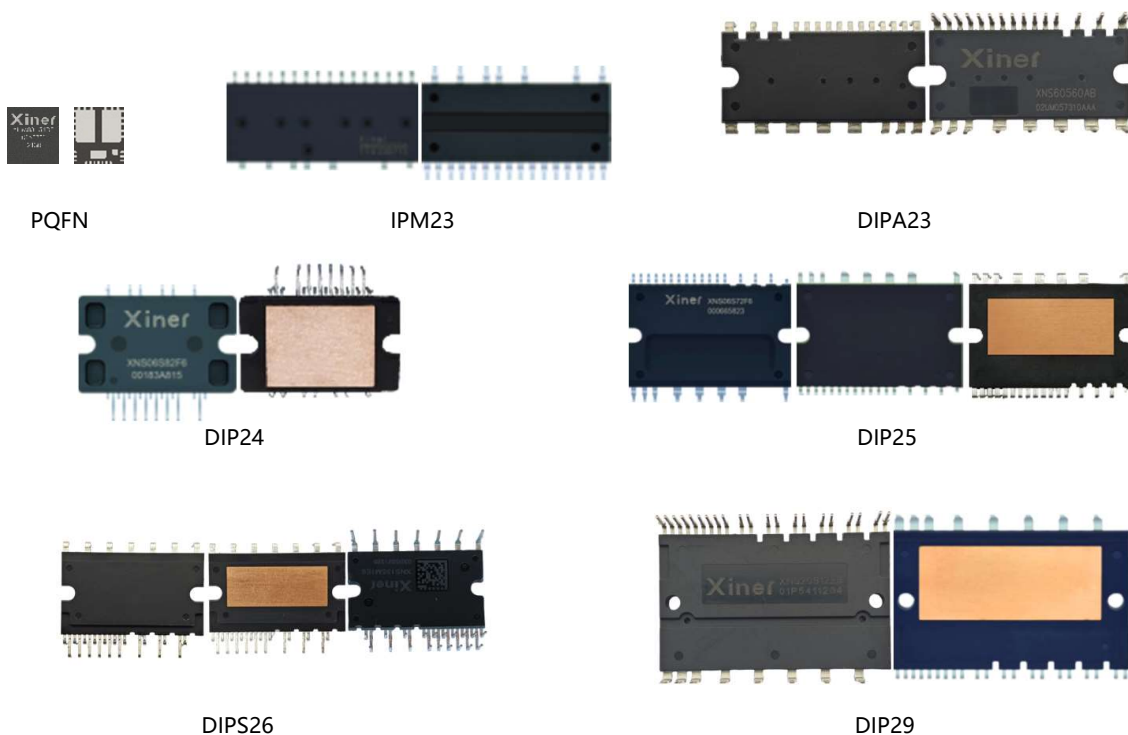

Application areas

- Fan: Air conditioning fan, range hood, fan, hair dryer, etc.
- Home appliances: Air conditioning, refrigerator, washing machine, heat pump, dishwasher, etc.
- Industrial control: Variable frequency drive, servo drive, robot, pump, etc.

Smart Power Module - PQFN Series

Focus on Energy Saving



Ultra-compact Half-Bridge Smart Power Module

The PQFN series smart power module utilizes a new generation of chip energy's driving IC, offering a highly integrated and ultra-compact solution for efficient electrical and light industrial applications. Primarily used for motor drivers in applications such as fans, air purifiers, ceiling fans, circulating pumps, and respirators.

By introducing new packaging and high-efficiency integration, the PQFN series presents a novel solution for integration, providing a new platform for device size reduction. It can reduce board area by up to 60% compared to existing three-phase motor control solutions.

The PQFN series consists of integrated half-bridge drivers and power devices. With PCB copper foil heat dissipation utilized in the packaging, cost savings are achieved through smaller package designs, eliminating the need for external heat sinks.

Product Features

- Internal High Voltage Gate Driver Circuit (HVIC)
- Higher integration with built-in BSD circuit
- Built-in undervoltage protection
- Integrated HVIC with temperature voltage output for temperature sampling
- Current range from 3A to 6A
- Ultra-compact and highly integrated packaging
- Supports heat dissipation through PCB copper foil without the need for a heatsink
- Same PCB area can accommodate more application scenarios
- Half-bridge structure for flexible applications
- Optimized and adopts low EMI design

Package information



PQFN 8*9 (8*9*0.9mm)

Application areas



Fan



Motor



Hair dryer



Vacuum cleaner



pumps



Air Conditioning IDU

Product list

Package information	Voltage Rating (V)	Current Specification (A)	Product Model	Recommended Power (W)	Device Type	Thermal Interface	Bootstrap Circuit	Interlock	Protection	Undervoltage	Overcurrent Protection	Temperature Output Type		Insulation Voltage (KV)
												NTC	VOT	
PQFN8*9	500	3	XNS03H54D5	60	MOS	PCB	•	•	•					1.5
		5	XNS05H54D5	130	MOS	PCB	•	•	•					
	600	4	XNS04H54D6	80	IGBT	PCB	•	•	•					
		6	XNS06H54D6	150	IGBT	PCB	•	•	•					
		4	XNS04H54E6	80	IGBT	PCB	•	•	•			•		
		6	XNS06H54E6	150	IGBT	PCB	•	•	•			•		

Smart Power Module - IPM23 Series

Focus on Energy Saving



Implementing Compact Variable Frequency Solution

The IPM23 is a small IPM series utilizing a new generation of chip energy's driving IC, designed for low-power motor drive applications including ventilation fans, washing machine and dishwasher pumps, louvers, air purifiers, and refrigerator fan drives. The IPM23 series utilizes industry-standard package outlines and processes compatible with various PCB substrates, providing an economical and efficient solution. This series features high reliability and efficient high-voltage IGBTs paired with matching driving ICs, specifically designed for variable frequency drive applications with rated voltages ranging from 250V to 600V.

Product Features

- Internal High Voltage Gate Driver Circuit (HVIC)
- Higher integration with built-in BSD circuit
- Suitable for various modules for 110VAC or 230VAC applications
- Built-in thermistor or voltage output for temperature sampling
- Built-in undervoltage protection
- Current ranging from 3A to 6A
- Internal integration of six high-voltage power devices
- Lower losses compared to similar modules in the market
- Optimized and adopts low EMI design

Package information

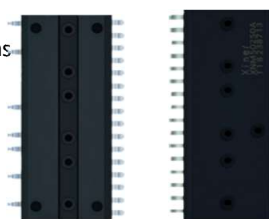

SOP23 (29*17*3.15mm)

Application areas



Fan



Hair dryer



pumps



Refrigerator



Vacuum cleaner



Air Conditioning Fan

Product list

Package information	Voltage Rating (V)	Current Specification (A)	Product Model	Recommended Power (W)	Device Type	Thermal Interface	Bootstrap Circuit	Interlock	Protection	Undervoltage Protection	Overcurrent Protection	Temperature Output Type		Insulation Voltage (KV)
												NTC	VOT	
SOP23 /DIP23	500	3	XNM50350ABS	150	MOS	塑料	•	•	•				•	1.5
		5	XNM50550ABS	170	MOS	塑料	•	•	•				•	
	600	3	XNM50360ABS	150	MOS	塑料	•	•	•				•	
		3	XNS50360AT(S)	150	IGBT	塑料	•	•	•			•		
		6	XNS50660AT(S)	200	IGBT	塑料	•	•	•			•		
		3	XNS50360AB(S)	150	IGBT	塑料	•	•	•				•	
		6	XNS50660AB(S)	200	IGBT	塑料	•	•	•				•	

Smart Power Module - DIPA23 Series

Focus on Energy Saving



Implementing Compact Variable Frequency Solution

The DIPA23 is a small IPM series utilizing a new generation of chip energy's driving IC, designed for low-power motor drive applications including ventilation fans, washing machine and dishwasher pumps, louvers, air purifiers, and refrigerator fan drives.

The DIPA23 series utilizes industry-standard package outlines and processes compatible with various PCB substrates, providing an economical and efficient solution. This series features high reliability and efficient high-voltage IGBTs paired with matching driving ICs, specifically designed for variable frequency drive applications with rated voltages

Product Features

- Internal High Voltage Gate Driver Circuit (HVIC)
- Higher integration with built-in BSD circuit
- Suitable for various modules for 110VAC or 230VAC applications
- Built-in voltage output for temperature sampling
- Built-in undervoltage protection
- Overcurrent protection
- Alarm signal lock function
- Current ranging from 3A to 15A
- Internal integration of six high-voltage power devices
- Lower losses compared to similar modules in the market
- Optimized and adopts low EMI design

Package information



DIPA23 (33.4*15*3.6mm)

Application areas



Fan



Hair dryer



pumps



Refrigerator



Vacuum cleaner



Air Conditioning Fan

Product list

Package information	Voltage Rating (V)	Current Specification (A)	Product Model	Recommended Power (W)	Device Type	Thermal Interface	Bootstrap Circuit	Interlock	Protection	Undervoltage	Overcurrent Protection	Temperature Output Type		Insulation Voltage (KV)
												NTC	VOT	
DIPA23	600	3	XNS60360AB	150	IGBT	Plastic	•		•	•		•	2.0	
		6	XNS60660AB	250	IGBT	Plastic	•		•	•		•		
		10	XNS61060AB	500	IGBT	Plastic	•		•	•		•		
		15	XNS61560AB	1000	IGBT	Plastic	•		•	•		•		



智能功率模块-DIP24 系列

Low-Power Motor Drive Application Solution

The DIP24 smart power module series, equipped with the latest chip energy's driving IC, is an ideal choice for advanced home appliances motor drives. This includes applications such as washing machines, air conditioning systems, refrigerators, and industrial drives, with current requirements ranging from 4A to 15A.

The DIP24 smart power module is a fully reliable mass-produced product, composed of chip energy's high-voltage driving IC, six IGBTs, and a thermistor. The lower bridge of the IGBT configuration utilizes separate emitter connections, enabling maximum flexibility in control algorithm selection. The power section is equipped with a complete set of protection features, including upper and lower bridge interlock protection, undervoltage, overcurrent, and protection lockout functions.

Product Features

- Internal High Voltage Gate Driver Circuit (HVIC)
- Higher integration with built-in BSD circuit
- Built-in thermistor for temperature sampling
- Built-in undervoltage protection
- Built-in upper and lower bridge interlock function
- Overcurrent protection
- Alarm signal lock function
- Optimized and adopts low EMI design
- Isolation level: 2000 Vrms/min

Package information

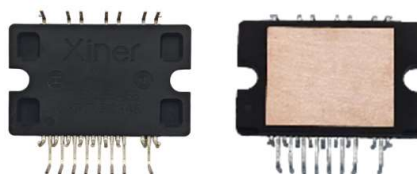

DIP24 DBC (29.3*18*3.4mm)

Application areas



Washing machine



Refrigerator



Industrial pump



Motor control



Servo motor



Air Conditioning IDU

Product list

Package information	Voltage Rating (V)	Current Specification (A)	Product Model	Recommended Power (W)	Device Type	Thermal Interface	Bootstrap Circuit	Interlock	Protection	Undervoltage	Overcurrent Protection	Temperature Output Type		Insulation Voltage (KV)
												NTC	VOT	
DIP24	600	4	XNS04S84F6	250	IGBT	DBC	•	•	•	•	•			2.0
		6	XNS06S84F6	400	IGBT	DBC	•	•	•	•	•			
		10	XNS10S84F6	800	IGBT	DBC	•	•	•	•	•			
		15	XNS15S84F6	1200	IGBT	DBC	•	•	•	•	•			

Smart Power Module - DIP25 Series

Focus on Energy Saving



Implementing Compact Variable Frequency Solution

The DIP25 Smart Power Module series utilizes a new generation of chip energy's driving IC, with applications including washing machines, air conditioning, refrigerators, and industrial frequency converters, with current requirements ranging from 6A to 30A. The DIP25 Smart Power Module consists of chip energy's high-voltage driving IC, six IGBTs, and a thermistor. The IGBT configuration utilizes separate emitter connections for the lower bridge, providing flexibility in selecting control algorithms. The power section includes a full range of protection functions, including upper and lower bridge interlock protection, undervoltage and overcurrent protection, and protection lockout functions.

Product Features

- Internal High Voltage Gate Driver Circuit (HVIC)
- Higher integration with built-in BSD circuit
- Built-in thermistor or voltage output for temperature sampling
- Built-in undervoltage protection
- Built-in upper and lower bridge interlock function
- Overcurrent protection
- Alarm signal lockout function
- Optimized and adopts low EMI design

Package information



DIP25 FP (38*29*3mm)



DIP25 DBC (38*29*3mm)

Application areas



Washing machine



Refrigerator



Industrial frequency converter controller



Motor control



High power Fan



Air Conditioning

Product list

Package information	Voltage Rating (V)	Current Specification (A)	Product Model	Recommended Power (W)	Device Type	Thermal Interface	Bootstrap Circuit	Interlock	Protection	Undervoltage	Overcurrent Protection	Temperature Output Type		Insulation Voltage (KV)	
												NTC	VOT		
DIP25-FP	600	6	XNS06S72F6	400	IGBT	Plastic	•	•	•	•	•	•		1.5	
		8	XNS08S72F6	800	IGBT	Plastic	•	•	•	•	•	•			
		15	XNS15S72F6	1200	IGBT	Plastic	•	•	•	•	•	•			
DIP25-DBC		6	XNS06S73E6	600	IGBT	DBC	•		•	•		•			
		10	XNS10S73E6	1000	IGBT	DBC	•		•	•		•			
		15	XNS15S73E6	1500	IGBT	DBC	•		•	•		•			
		20	XNS20S73E6	2000	IGBT	DBC	•		•	•		•			
	30	XNS30S73E6	3000	IGBT	DBC	•		•	•		•				

Smart Power Module - DIPS26 Series

Focus on Energy Saving



Implementing Compact Variable Frequency Solution

The DIPS26 Smart Power Module series utilizes a new generation of chip energy's driving IC, with current requirements ranging from 5A to 20A. It is primarily aimed at compressor and fan motor applications in residential and commercial air conditioning equipment, as well as in small inverters and servo controllers.

The DIPS26 Smart Power Module consists of chip energy's high-voltage driving IC and six IGBTs. The IGBT configuration utilizes separate emitter connections for the lower bridge, providing flexibility in selecting control algorithms. The power section includes a full range of protection functions, including upper and lower bridge interlock protection, undervoltage and overcurrent protection, and protection lockout functions.

Product Features

- Internal High Voltage Gate Driver Circuit (HVIC)
- Higher integration with built-in BSD circuit
- Built-in voltage output for temperature sampling
- Built-in undervoltage protection
- Built-in upper and lower bridge interlock function
- Overcurrent protection
- Alarm signal lockout function
- Optimized and adopts low EMI design

Package information



DIPS26 DBC
(32.8*18.8*10.8mm)

DIPS26 FP
(32.8*18.8*10.8mm)

Application areas



Variable frequency drive (VFD)



Servo controller



Commercial Air Conditioning

Product list

Package information	Voltage Rating (V)	Current Specification (A)	Product Model	Recommended Power (W)	Device Type	Thermal Interface	Bootstrap Circuit	Interlock	Undervoltage Protection	Overcurrent Protection	Temperature Output Type		Insulation Voltage (KV)
											NTC	VOT	
DIPS26-FP	600	5	XNS05SM2E6	400	IGBT	Plastic	•		•	•		•	2
		8	XNS08SM2E6	700	IGBT	Plastic	•		•	•		•	
		10	XNS10SM2E6	900	IGBT	Plastic	•		•	•		•	
		15	XNS15SM2E6	1200	IGBT	Plastic	•		•	•		•	
DIPS26-DBC	600	5	XNS05SM1E6	500	IGBT	DBC	•		•	•		•	2
		8	XNS08SM1E6	800	IGBT	DBC	•		•	•		•	
		10	XNS10SM1E6	1000	IGBT	DBC	•		•	•		•	
		15	XNS15SM1E6	1500	IGBT	DBC	•		•	•		•	
		20	XNS20SM1E6	2000	IGBT	DBC	•		•	•		•	

Smart Power Module - DIP29 Series

Focus on Energy Saving



Implementing High-Performance High-Power Variable Frequency Solution

The DIP29 Smart Power Module series utilizes a new generation of chip energy's driving IC, with applications including central air conditioning, servo controllers, and industrial frequency converters, with current requirements ranging from 20A to 50A. The power section includes a full range of protection functions, including upper and lower bridge interlock protection, undervoltage and overcurrent protection, and protection lockout functions.

Product Features

- Internal High Voltage Gate Driver Circuit (HVIC)
- Higher integration with built-in BSD circuit
- Built-in thermistor or voltage output for temperature sampling
- Built-in undervoltage protection
- Built-in upper and lower bridge interlock function
- Overcurrent protection
- Alarm signal lockout function
- Utilizes DBC (Direct Bond Copper) heat dissipation structure
- Optimized and adopts low EMI design
- Product XNC20S12FT adopts SiC (Silicon Carbide) chip technology

Package information

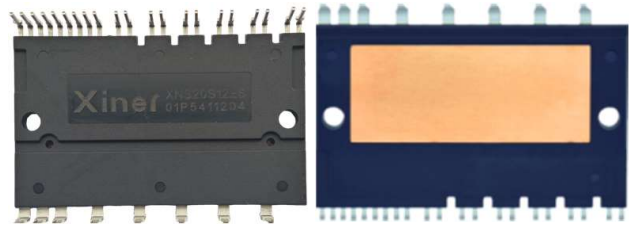

DIP29 DBC (52.5*31*5.6mm)

Application areas



Variable frequency drive (VFD)



Servo controller



Commercial Air Conditioning

Product list

Package information	Voltage Rating (V)	Current Specification (A)	Product Model	Recommended Power (W)	Device Type	Thermal Interface	Bootstrap Circuit	Interlock	Protection	Undervoltage	Overcurrent Protection	Temperature Output Type		Insulation Voltage (KV)
												NTC	VOT	
DIP29	600	30	XNS30S12E6	3000	IGBT	DBC	•	•	•	•	•		•	2.5
		50	XNS50S12E6	5000	IGBT	DBC	•	•	•	•	•		•	
	1200	10	XNS10S12FT	2000	IGBT	DBC	•	•	•	•	•	•		
		15	XNS15S12FT	3000	IGBT	DBC	•	•	•	•	•	•		
		25	XNS25S12FT	4000	IGBT	DBC	•	•	•	•	•	•		
		35	XNC20S12FT	5000	SiC	DBC	•	•	•	•	•	•		

IGBT Power Module

Focus on Energy Saving



Product Features

- Utilizing advanced Trench + FS IGBT wafer fabrication technology
- Voltage withstand capacity: 600V/1200V/1700V
- Highly integrated
- Low switching losses
- Low conduction losses
- $T_{vjop}=150^{\circ}\text{C}$ (Maximum junction operating temperature)
- V_{cesat} with positive temperature coefficient
- Integrated NTC temperature sensor
- Compliant with RoHS regulations

Package information

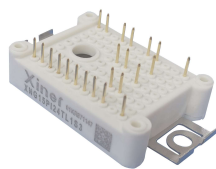

L1



L2



C1



C2

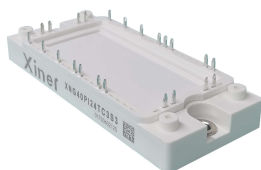

C3

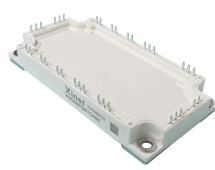

C4



C5



C5-SiC



X



H4



W



H6

L Series (Small PIM Power) Modules

Focus on Energy Saving



The L Series is a highly integrated and compact power module used in home appliances and industrial applications. The module's topology includes rectifier units, brake units, and inverter units, primarily used for motor drivers in applications such as small power industrial frequency converters, servo controllers, industrial fans, industrial heat pumps, and air conditioning systems. The L Series is available in two voltage levels: 600V and 1200V.

Application Diagram

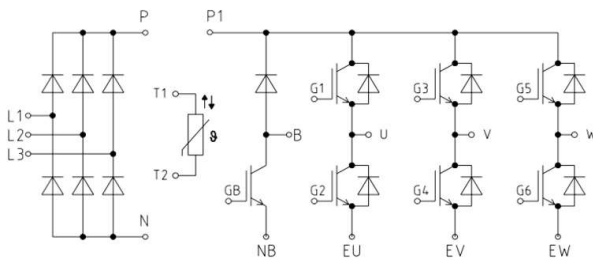

Package information

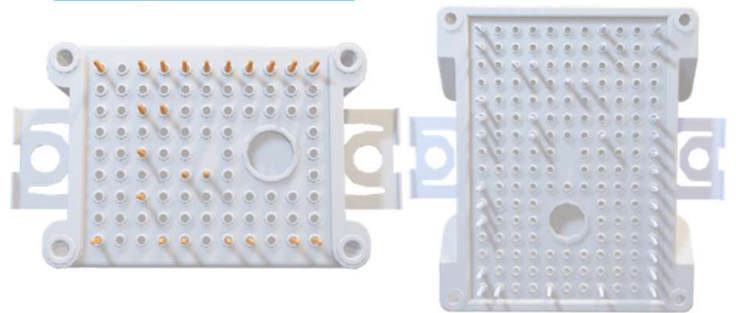

L1 Package (33.8 x 48 x 12mm)

L2 Package (56.7 x 62.8 x 12mm)

Application areas



Air Conditioning



Servo control



Industrial Fan



Industrial frequency conversion

Product list

Voltage Level (V)	Current Specification (A)	Product Model	Device type	Topology	Isolation voltage (Kv)	Switching frequency (KHz)	Package information
600	20	XNG20PI12TL1S3	IGBT	PIM	2.5	< 20	L1
	30	XNG30PI12TL1S3	IGBT	PIM	2.5	< 20	L1
	50	XNG50PI12TL2S3	IGBT	PIM	2.5	< 20	L2
1200	15	XNG15PI24TL1S3	IGBT	PIM	2.5	< 20	L1
	25	XNG25PI24TL1S3	IGBT	PIM	2.5	< 20	L1
	25	XNG25PI24TL2S3	IGBT	PIM	2.5	< 20	L2
	40	XNG40PI24TL2S3	IGBT	PIM	2.5	< 20	L2
	50	XNG50PI24TL2S	IGBT	PIM	2.5	< 20	L2
	50	XNG50DT12L2S	IGBT	Six Pack	2.5	< 20	L2
	75	XNG75DT12L2S	IGBT	Six Pack	2.5	< 20	L2

L2 Series (Three-Level) Modules

Focus on Energy Saving



L2 Series Three-Level is a highly integrated and compact power module. The IGBT chips utilize Trench Field Stop IGBT technology, providing high power density, low switching losses, low on-state voltage drop, and high reliability. The module topology uses the I-NPC1 circuit, primarily employed in the field of power quality management such as SVG (Static Var Generator), APF (Active Power Filter), etc.

Application Diagram

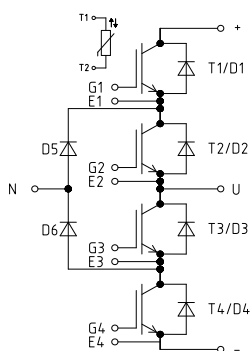

Package information

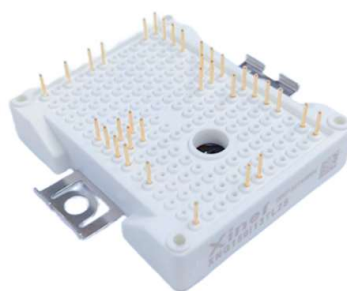

L2 Package (56.7 x 62.8 x 12mm)

Application areas



SVG Reactive Power Compensation



APF Active filter

Product list

Voltage Level (V)	Current Specification (A)	Product Model	Device type	Topology	Isolation voltage(Kv)	Switching frequency (KHz)	Package information
650	100	XNG100IK07L2E	IGBT	NPC1	2.5	< 20	L2
	150	XNG150IK07L2E	IGBT	NPC1	2.5	< 20	L2

C1/C2 Series (Half Bridge) Modules

Focus on Energy Saving



Half bridge module products compatible with market-standard 34mm and 62mm packages. The IGBT chips adopt advanced IGBT technology with fast recovery diodes, featuring high switching speed, low on-state losses, strong surge capability, high reliability, etc. The products are primarily used in industrial power supplies, induction heating, welding machines, motor drives, and photovoltaic applications.

Application Diagram

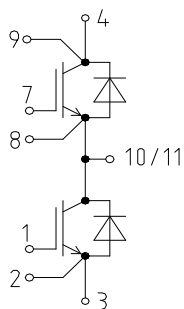

Package information



C1 Package (94×34×30mm)



C2 Package (106×62×30mm)

Application areas



Induction Heating



Industrial power supply



Welding machine



Solar Energy



Industrial Fan



Industrial frequency conversion

Product list

Voltage Level (V)	Current Specification (A)	Product Model	Device type	Topology	Isolation voltage(Kv)	Switching frequency (KHz)	Package information
1200V	50	XNG50B24UC1S	IGBT	Half Bridge	2.5	>20	C1
	75	XNG75B24UC1S	IGBT	Half Bridge	2.5	>20	C1
	100	XNG100B24UC1S	IGBT	Half Bridge	2.5	>20	C1
	150	XNG150B24UC1S	IGBT	Half Bridge	2.5	>20	C1
	150	XNG150B24UC2S	IGBT	Half Bridge	2.5	>20	C2
	200	XNG200B24UC2S	IGBT	Half Bridge	2.5	>20	C2
	300	XNG300B24UC2S	IGBT	Half Bridge	2.5	>20	C2
	450	XNG450B24UC2S	IGBT	Half Bridge	2.5	>20	C2
	200	XNG200B24KC2S5	IGBT	Half Bridge	2.5	< 20	C2
	300	XNG300B24KC2S5	IGBT	Half Bridge	2.5	< 20	C2
	450	XNG450B24KC2S	IGBT	Half Bridge	2.5	< 20	C2
	600	XNG600BL12C2S	IGBT	Half Bridge	2.5	< 20	C2
1700	300	XNG300B34KC2S8	IGBT	Half Bridge	3.4	< 20	C2

C3/C4 Series (Small to Medium PIM Power) Modules

Focus on Energy Saving



C3/C4 Series is a highly integrated and relatively compact power module designed for commercial and industrial applications. The module's topology includes rectifier units, brake units, and inverter units, primarily used for motor drivers in applications such as industrial frequency converters, servo controllers, industrial fans, industrial pumps, and commercial air conditioning systems with power ratings up to 37kW. The C3/C4 series is primarily available in a 1200V voltage level.

Application Diagram

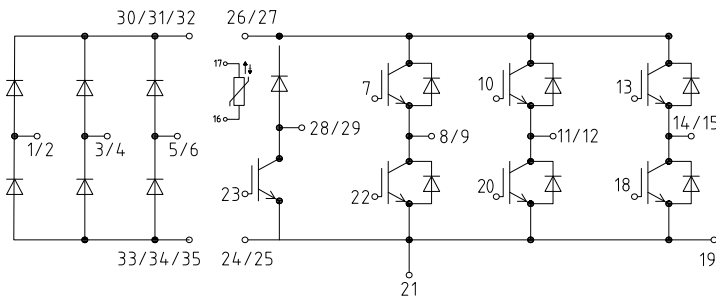

Package information



C3 Package (38 x 107.5 x 17mm)



C4 Package (62 x 122 x 17mm)

Application areas



Air Conditioning



pumps



Industrial Fan



Industrial frequency conversion

Product list

Voltage Level (V)	Current Specification (A)	Product Model	Device type	Topology	Isolation voltage(Kv)	Switching frequency (KHz)	Package information
1200	15	XNG15PI24TC3	IGBT	PIM	2.5	< 20	C3
	25	XNG25PI24TC3AS3	IGBT	PIM	2.5	< 20	C3
	25	XNG25PI24TC3	IGBT	PIM	2.5	< 20	C3
	35	XNG35PI24TC3	IGBT	PIM	2.5	< 20	C3
	40	XNG40PI24TC3AS3	IGBT	PIM	2.5	< 20	C3
	40	XNG40PI24TC3S3	IGBT	PIM	2.5	< 20	C3
	50	XNG50PI24TC3	IGBT	PIM	2.5	< 20	C3
	50	XNG50PI24TC4S5	IGBT	PIM	2.5	< 20	C4
	50	XNG50PI24TC4AS5	IGBT	PIM	2.5	< 20	C4
	75	XNG75PI24TC4AS5	IGBT	PIM	2.5	< 20	C4
	75	XNG75PI24TC4S5	IGBT	PIM	2.5	< 20	C4
	100	XNG100PI24TC4S5	IGBT	PIM	2.5	< 20	C4
	150	XNG150PI24TC4	IGBT	PIM	2.5	< 20	C4

C3/C4 Series (Small to Medium Six Pack Power) Modules

Focus on Energy Saving



C3/C4 Series is a highly integrated and relatively compact power module designed for industrial applications. The module's topology includes inverter units. C3 is primarily used for motor drivers in applications such as industrial frequency converters, high-power servo controllers, and automotive air conditioning systems with power ratings ranging from 7.5kW to 18.5kW. C4 is primarily used for motor drivers in applications such as industrial frequency converters, crane systems, and automotive air conditioning systems with power ratings ranging from 30kW to 55kW. The C3/C4 series is primarily available in a 1200V voltage level.

Application Diagram

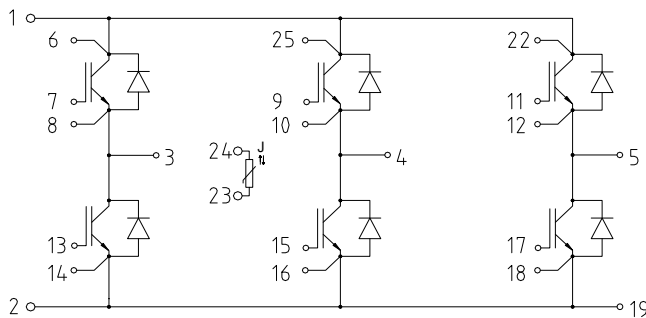

Package information



C3 Package (38 x 107.5 x 17mm)



C4 Package (62 x 122 x 17mm)

Application areas



Air Conditioning



pumps



Industrial Fan



Industrial frequency conversion

Product list

Voltage Level (V)	Current Specification (A)	Product Model	Device type	Topology	Isolation voltage(Kv)	Switching frequency (KHz)	Package information
650V	100	XNG100D13TC3S	IGBT	Six Pack	2.5	< 20	C3
1200	50	XNG50D24TC3S	IGBT	Six Pack	2.5	< 20	C3
	75	XNG75D24TC3S	IGBT	Six Pack	2.5	< 20	C3
	100	XNG100D24TC3S	IGBT	Six Pack	2.5	< 20	C3
	100	XNG100D24TC4S	IGBT	Six Pack	2.5	< 20	C3
	150	XNG150D24TC4	IGBT	Six Pack	2.5	< 20	C3
	150	XNG150D24KC4A5	IGBT	Six Pack	2.5	< 20	C4
	150	XNG150D24KC4A5D	IGBT	Six Pack	2.5	< 20	C4
	200	XNG200D24KC4S	IGBT	Six Pack	2.5	< 20	C4



C5 Series (Half Bridge) Modules

C5 half-bridge module products are compatible with market-standard packages. The IGBT chips utilize Trench Field Stop IGBT technology, offering high power density, low switching losses, low on-state voltage drop, and high reliability. The products are primarily used in the fields of photovoltaics, energy storage, wind power generation, SVG (Static Var Generator), and motor drives.

Application Diagram

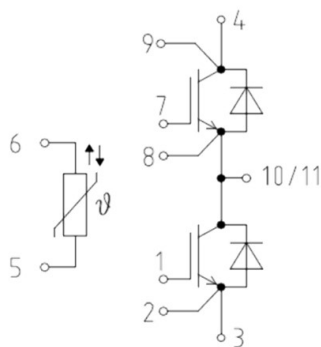

Package information



C5 Package (152×62×17mm)



C5_SiC Package (152×62×17mm)

Application areas



Solar



Energy Storage



Wind power generation



Motor drive





SVG Reactive Power Compensation



New Energy Vehicles

Product list

Voltage Level (V)	Current Specification (A)	Product Model	Device type	Topology	Isolation voltage(Kv)	Switching frequency (KHz)	Package information
1200V	300	XNG300B24LC5E	IGBT	Half Bridge	2.5	< 20	C5
	450	XNG450B24LC5E	IGBT	Half Bridge	2.5	<20	C5
	450	XNG450B24KC5A5	IGBT	Half Bridge	2.5	< 20	C5
	600	XNG600B24LC5E	IGBT	Half Bridge	2.5	<20	C5
	600	XNG600B24LC5E-Y 	IGBT	Half Bridge	2.5	< 20	C5
	800	XNG800B24LC5E	IGBT	Half Bridge	2.5	< 20	C5
	1000	XNC1000BT12YA-J35 	SiC	Half Bridge	2.5	> 10	C5_SiC
1700V	300	XNG300B34KC5E	IGBT	Half Bridge	3.4	< 20	C5
	450	XNG450B34KC5A5	IGBT	Half Bridge	3.4	< 20	C5
	600	XNG600B34LC5E	IGBT	Half Bridge	3.4	< 20	C5
	600	XNG600BT17ZA-J11 	IGBT	Half Bridge	3.4	< 20	C5

H4 Series (Medium Six Pack Power) Modules

Focus on Energy Saving



H4 Series is a power module designed for automotive applications in passenger cars and commercial vehicles. The module topology includes inverter units, primarily used for motor drivers with rated power levels ranging from 30kW to 55kW. The H4 series is primarily available in a 750V voltage level and includes both PinFin and flat baseplate versions. The module's pin-to-pin compatibility with mainstream models in the market meets the requirements of A0-class vehicles, delivery vans, and other vehicle types.

Package information



H4 Package Pinfin(140 x 72 x 25.4mm)



H4 Package Flat panel (140 x 72 x 17.5mm)

Application Diagram

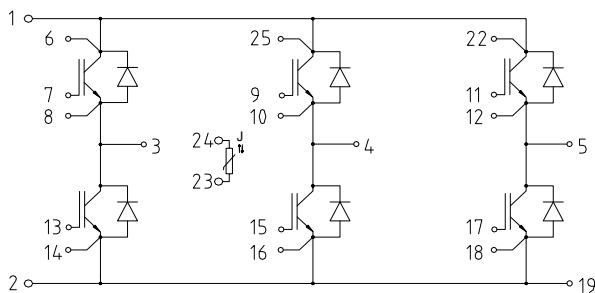

Application areas



New Energy Vehicles

Product list

Voltage type (V)	Current Specification (A)	Product Model	Device type	Topology	Isolation voltage(Kv)	Switching frequency (KHz)	Package information	Structural form
750	400	XNG400DT08H4A-J11	IGBT	Six Pack	3	< 20	H4	Flat panel
	500	XNG500DT08H4A-H11	IGBT	Six Pack	3	< 20	H4	Pinfin
1200	250	XNG250D24TH4AH	IGBT	Six Pack	3	< 20	H4	Pinfin

X Series (Medium Six Pack Power) Modules

Focus on Energy Saving



The X Series is a power module designed for automotive applications in passenger cars and commercial vehicles. The module topology includes inverter units, primarily used for motor drivers with rated power levels ranging from 30kW to 55kW. The X series is primarily available in a 750V voltage level and includes both PinFin and flat baseplate versions. The module's pin-to-pin compatibility with mainstream models in the market meets the requirements of A0-class vehicles, delivery vans, and other vehicle types.

Application Diagram

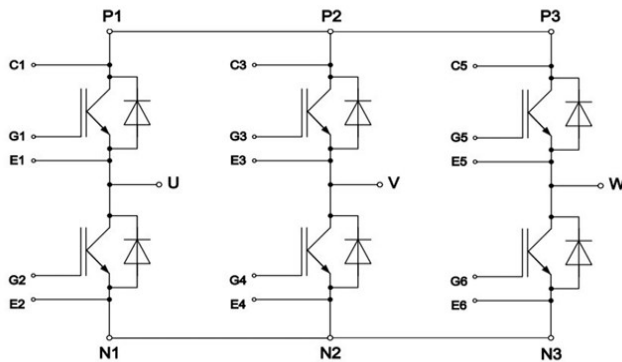

Package information



X Package
Flat panel (140 x 72 x 17.5mm)
Pinfin ()

Application areas



New Energy Vehicles

Product list

Voltage type (V)	Current Specification (A)	Product Model	Device type	Topology	Isolation voltage(Kv)	Switching frequency (KHz)	Package information	Structural form
750	400	XNG400DT08XA-J11	IGBT	Six Pack	3	< 20	X	Flat panel
	500	XNG500DT08XA-H11	IGBT	Six Pack	3	< 20	X	Pinfin
	550	XNG550DT08XA-H16	IGBT	Six Pack	3	< 20	X	Pinfin
	600	XNG600DT08XA-H14	IGBT	Six Pack	3	< 20	X	Pinfin
1200	250	XNG250DT12XA-H16	IGBT	Six Pack	3	< 20	X	Pinfin

W Series (High Power Six Pack Power) Modules

Focus on Energy Saving



W Series is a power module designed for automotive applications in passenger cars and commercial vehicles. It includes Si-based IGBTs and SiC MOSFETs. The module topology comprises inverter units primarily used for motor drivers with rated power levels ranging from 132kW to 185kW. The W series includes both 750V and 1200V voltage levels, with PinFin baseplates as the primary option. The module's pin-to-pin compatibility with mainstream models in the market meets the requirements of A-class vehicles, SUVs, and other vehicle types.

Application Diagram

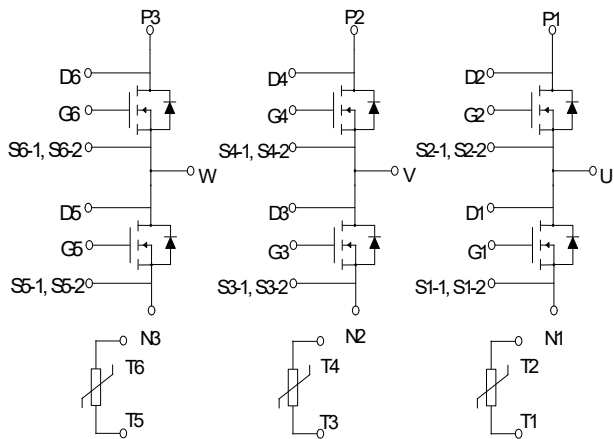

Package information

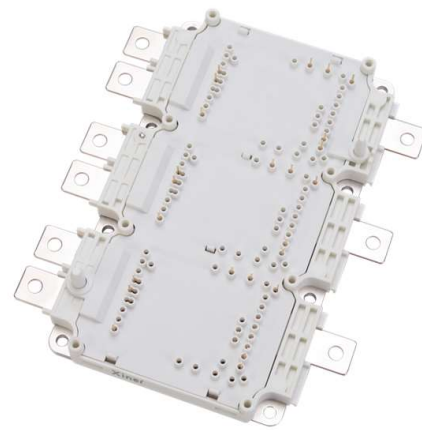

HPD Package
Pinfin(92 x 154.5 x 22mm)

Application areas



New Energy Vehicles

Product list

Voltage Level (V)	Current Specification (A)	Product Model	Device type	Topology	Isolation voltage(Kv)	Switching frequency (KHz)	Package information	Structural form
750	400	XNG400DT08WA-CH11	IGBT	Six Pack	3	< 20	W	Pinfin
	600	XNG600DT08WA-CH11	IGBT	Six Pack	3	< 20	W	Pinfin
	950	XNG950DT08WA-CH14	IGBT	Six Pack	3	< 20	W	Pinfin
	1200	XNG1200DT08WA-CH34	IGBT	Six Pack	3	< 20	W	Pinfin

H6 Series (Medium Six Pack Power) Modules

Focus on Energy Saving



H6 Series is a universal automotive power module designed for use in passenger cars and commercial vehicles. The module topology comprises inverter units primarily used for motor drivers with rated power levels ranging from 30kW to 55kW. The H6 series is primarily available in a 750V voltage level and includes both PinFin and flat baseplate options. The module's pin-to-pin compatibility with mainstream models in the market meets the requirements of A0-class vehicles, delivery vans, and other vehicle types.

Application Diagram

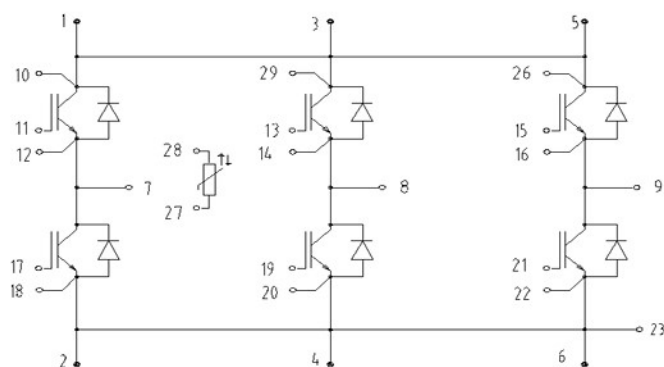

Package information



H6 Package
Pinfin(140 x 72 x 25.4mm)

Application areas



New Energy Vehicles

Product list

Voltage type (V)	Current Specification (A)	Product Model	Device type	Topology	Isolation voltage(Kv)	Switching frequency (KHz)	Package information	Structural form
750	550	XNG550DT08H6A-H16	IGBT	Six Pack	3	< 20	H6	Pinfin
750	600	XNG600DT08H6A-H14	IGBT	Six Pack	3	< 20	H6	Pinfin